

Chapter Seven

Fuel Injection and Governor Systems

This chapter describes operation of the fuel injection and governor systems and service procedures. Refer to Chapter Two for troubleshooting procedures. Refer to Chapter Three for maintenance procedures. Refer to Chapter Five for a description of diesel engine operation.

Tables 1-3 are located at the end of this chapter.

WARNING

Serious fire hazards always exist around diesel fuel. Do not allow any smoking in areas where fuel is present. Always have a fire extinguisher, rated for fuel and electrical fires, on hand when refueling or servicing any part of the fuel system.

WARNING

Fuel emerges from the injector and high-pressure fuel fittings with sufficient force to penetrate the skin, which may cause blood poisoning. Wear goggles and cover exposed skin when working on high-pressure components.

FUEL INJECTION FUNDAMENTALS

Engine operation is described under *Diesel Engine Fundamentals* in Chapter Five.

The major components of the diesel fuel system are the fuel tank, fuel filters, injection pump and injection nozzle(s) (**Figure 1**). A feed (transfer) pump moves fuel from the fuel tank through the filters to the fuel injection pump. Governor operation is described in *Governor System* in this chapter.

Fuel Injection Pump

The fuel injection pump forces fuel into the fuel injector(s), which direct fuel into the engine combustion chamber. The pump raises fuel pressure to approximately 17000 kPa (2540 psi), while also controlling the time and amount of fuel injected.

The diesel injection pumps used on the engines covered in this manual operate on the plunger and cam principle. Refer to **Figure 2** and **Figure 3**. A rotating cam in the engine causes a plunger in the fuel injection pump to move in a cylinder and pump fuel to the injector nozzle. A delivery valve and spring establish the beginning and ending of injection while also maintaining residual pressure in the injection line. The plunger is designed to alter fuel flow when it is rotated. Fuel control is achieved by moving the fuel control rack, which rotates the fuel plunger pinion and plunger.

1

FUEL INJECTION SYSTEM

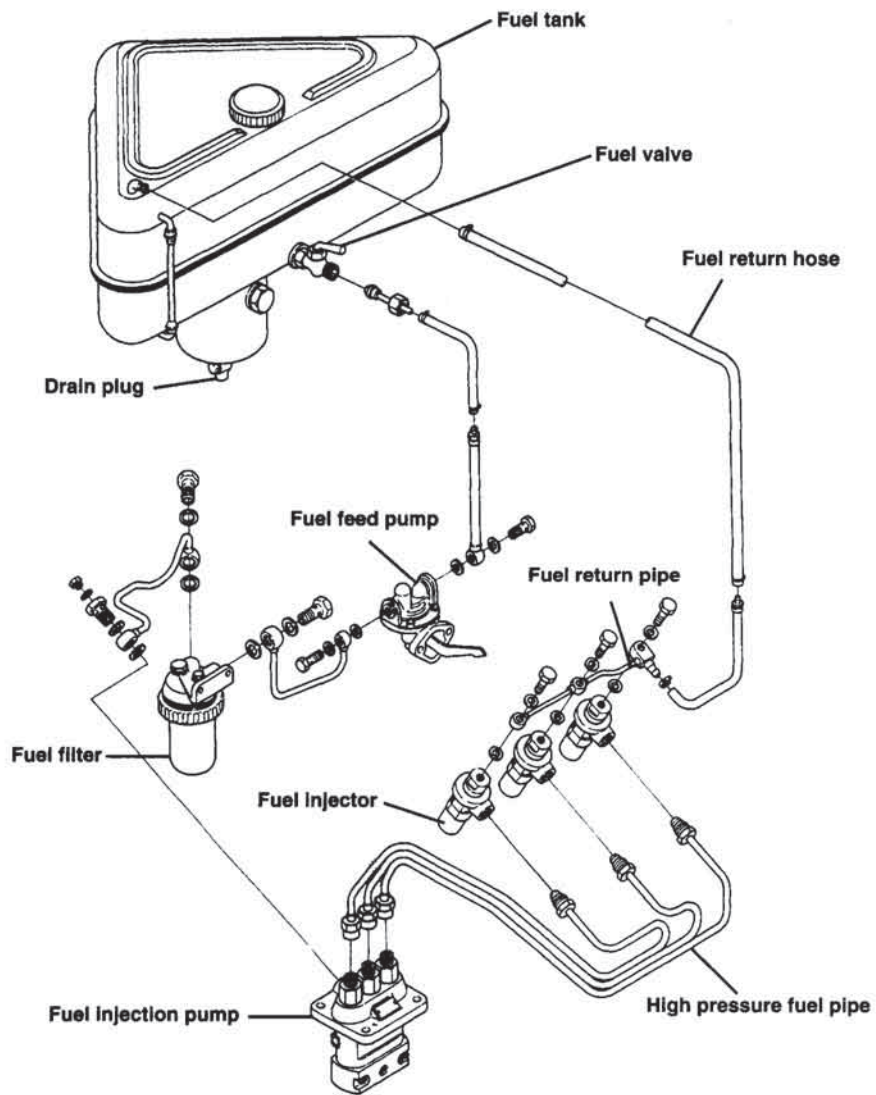

7

Individual pumping elements are used on single-cylinder engines as shown in **Figure 4**. Multiple-cylinder engines are equipped with pumping elements combined in a single unit as shown in **Figure 5**.

Fuel injection pumps are precision-built units that require clean fuel to operate properly. The extremely close tolerances and high injection pressure dictate that specialized equipment and experienced technicians are needed to service fuel injection pumps. If properly operated and maintained, a fuel injection pump will provide long-lasting, trouble-free service.

Fuel Injector

A fuel injector (A, **Figure 6**) is required for each cylinder to inject fuel into the combustion chamber. A high-pressure fuel line (B, **Figure 6**) directs fuel from the fuel injection pump to the fuel injector, while a fuel return line (C, **Figure 6**) carries bypass fuel back to the fuel tank. Refer to **Figure 7** for an exploded view of the fuel injector.

The engines covered in this manual are equipped with an inward opening, throttling-pintle type fuel injector (**Figure 8**). High fuel pressure from the injection pump enters the injection nozzle, surrounds the nozzle valve and forces the valve away from the seat. The pressure exerted by the spring above the nozzle holds the nozzle valve closed until the pressure of the fuel rises higher than spring pressure. The fuel delivered by the pump sprays from the nozzle tip into the combustion chamber when the valve opens. After the fuel is injected, fuel pressure decreases and the spring once again closes the valve.

The injection nozzle atomizes the fuel to help mix fuel with the compressed air in the engine's cylinder. The fuel must be broken into very small particles so that the fuel will quickly absorb heat from the compressed (hot) air, change to a vapor, then ignite. The design of the nozzle tip affects the size and shape of the fuel spray. The throttling pintle reduces the amount of fuel injected for a given orifice and causes a delay in the injection of the principal amount of fuel.

Excess fuel is routed from the injectors back to the fuel tank through a fuel return line.

Fuel and Fuel Filters

Clean, moisture-free fuel is very important to a diesel fuel system. As well as acting as the fuel for combustion, diesel fuel is also a lubricant for many of the internal moving parts in the fuel system. The close tolerances of the in-

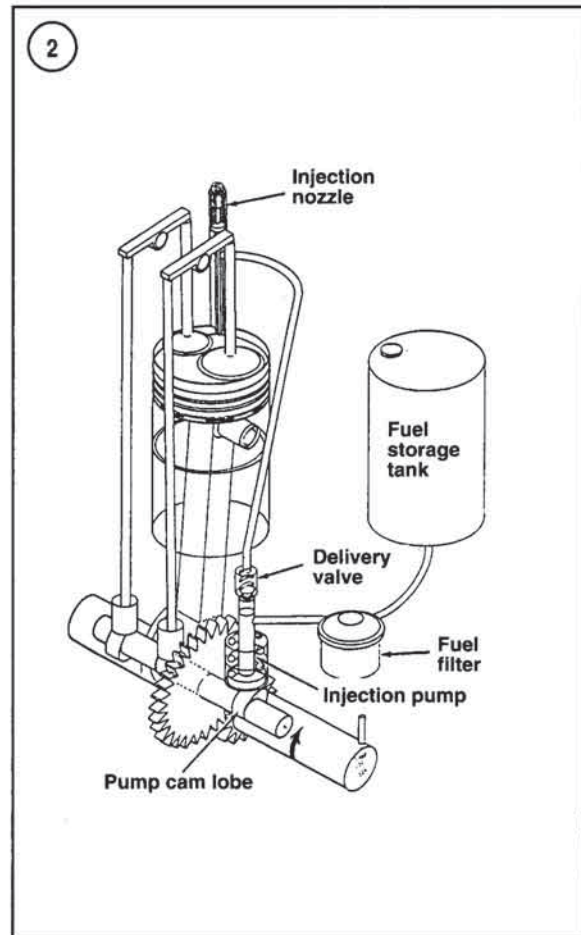

jection pump and nozzles are easily damaged by solid particles in the fuel as well as by water in the fuel.

All diesel fuel contains some sulfur, which forms sulfuric acid if water mixes with the sulfur. The sulfuric acid will quickly erode the precision parts of the pump and nozzles. Extra care must be exercised in the storage and handling of diesel fuel to prevent contamination.

Diesel fuel is graded according to the composition of the fuel after passing through the refining process. Common diesel fuel grades are 1D and 2D, with 1D the lighter fuel. The recommended fuel for the Yanmar engines covered by this manual is 2-D diesel fuel.

Filters are included within the system to remove solid particles and absorb moisture. In many cases, at least two filtering stages plus a water trap are incorporated to help ensure only clean fuel reaches the fuel injection pump. The primary filter (nearest the fuel tank) removes sediment and water from the fuel. The secondary filter removes very fine particles from the fuel. Both filters must

3

INJECTION PUMP

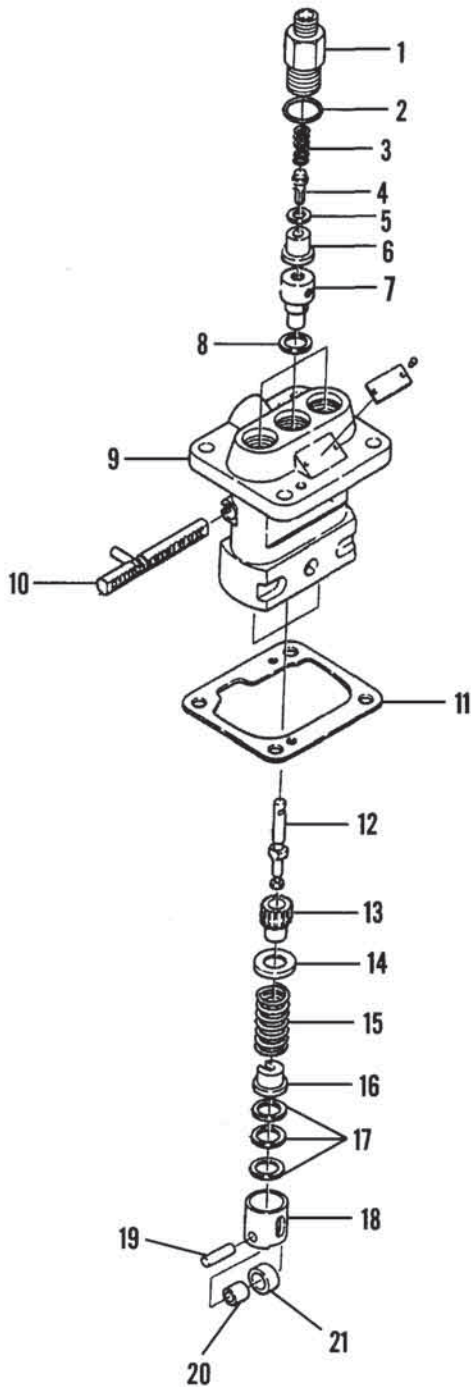

- 1. Delivery valve holder
- 2. O-ring
- 3. Spring
- 4. Delivery valve
- 5. Gasket
- 6. Delivery valve seat
- 7. Barrel
- 8. Gasket
- 9. Pump body
- 10. Control rack
- 11. Shims
- 12. Plunger
- 13. Control sleeve
- 14. Washer
- 15. Spring
- 16. Spring seat
- 17. Shims
- 18. Tappet
- 19. Pin
- 20. Bearing
- 21. Roller

7

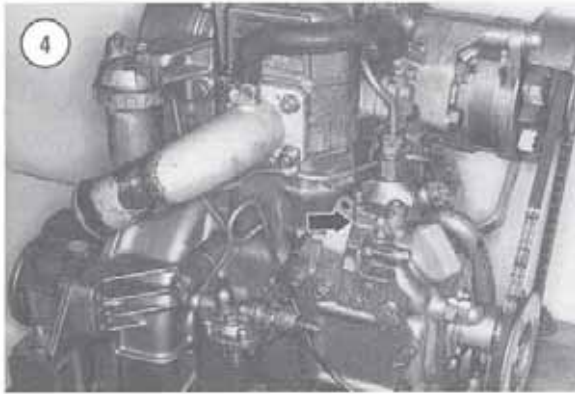

be operating properly to adequately protect the fuel injection system. Failure to maintain fuel filters and use clean fuel can result in engine stoppage and expensive replacement or repair of the injection pump or injectors.

Fuel Transfer Pump

The fuel transfer pump (A, **Figure 9**) moves fuel from the fuel tank to the fuel injection pump. The pump is necessary when the fuel tank is lower than the fuel injection pump. A primer lever on the side of the transfer pump permits manual operation of the fuel pump diaphragm. Priming or bleeding the fuel system requires operation of the primer lever so fuel flows to the injection system with the engine stopped.

FUEL INJECTION SYSTEM BLEEDING

Air in the fuel system can cause rough engine operation or stoppage. Bleeding purges air from the system. Bleed the system anytime fuel line connections are disconnected or fuel components are removed. To ensure all air is removed, perform the complete bleeding procedure described in the following steps:

1. Open the bleed screw on the fuel filter (**Figure 10**). Make sure the fuel valve on the fuel tank is open.

NOTE

Be prepared to contain and wipe up expelled fuel.

2. Operate the priming lever (B, **Figure 9**) on the fuel transfer pump while observing the fuel expelled from the bleed screw hole. Continue to operate the priming lever until air-free fuel is expelled, then close the air bleed screw.

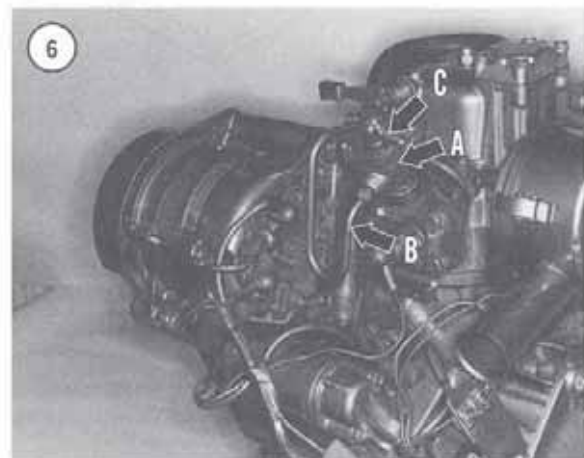
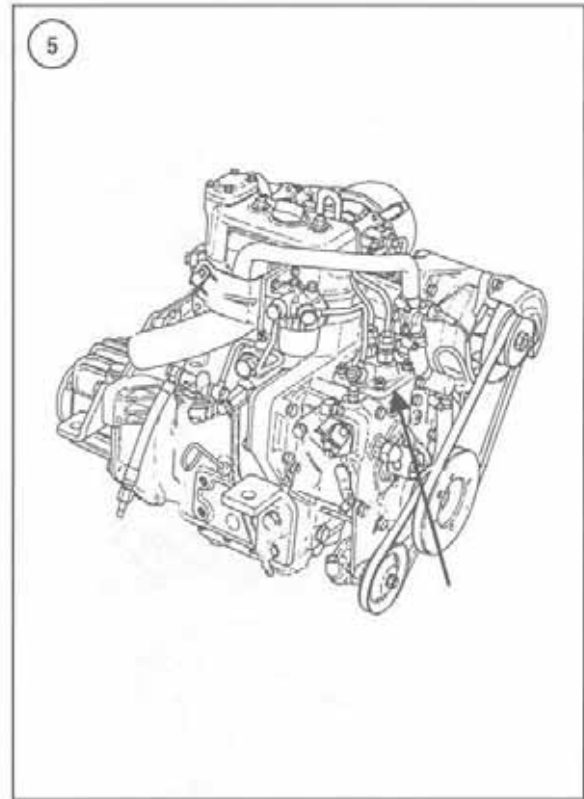

3. Open the air bleed screw (**Figure 11**) on the fuel injection pump.

4. Operate the priming lever (B, **Figure 9**) on the fuel transfer pump while observing the fuel expelled from the bleed screw hole. Continue to operate the priming lever until air-free fuel is expelled, then close the air bleed screw.

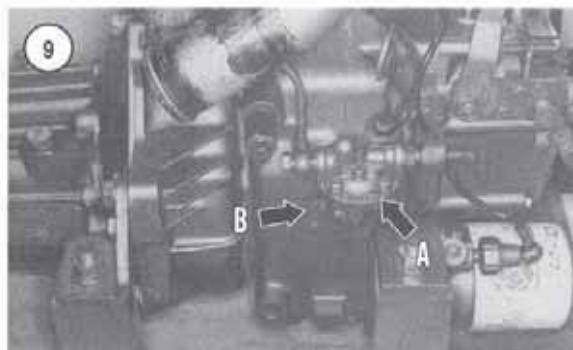
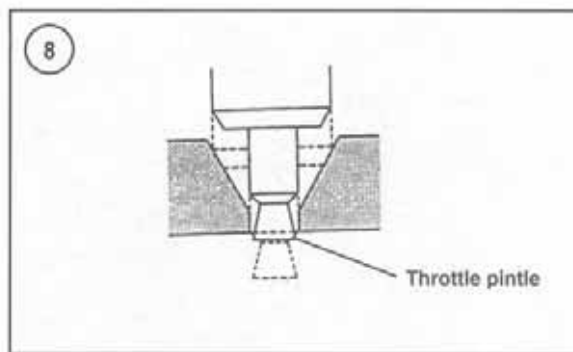
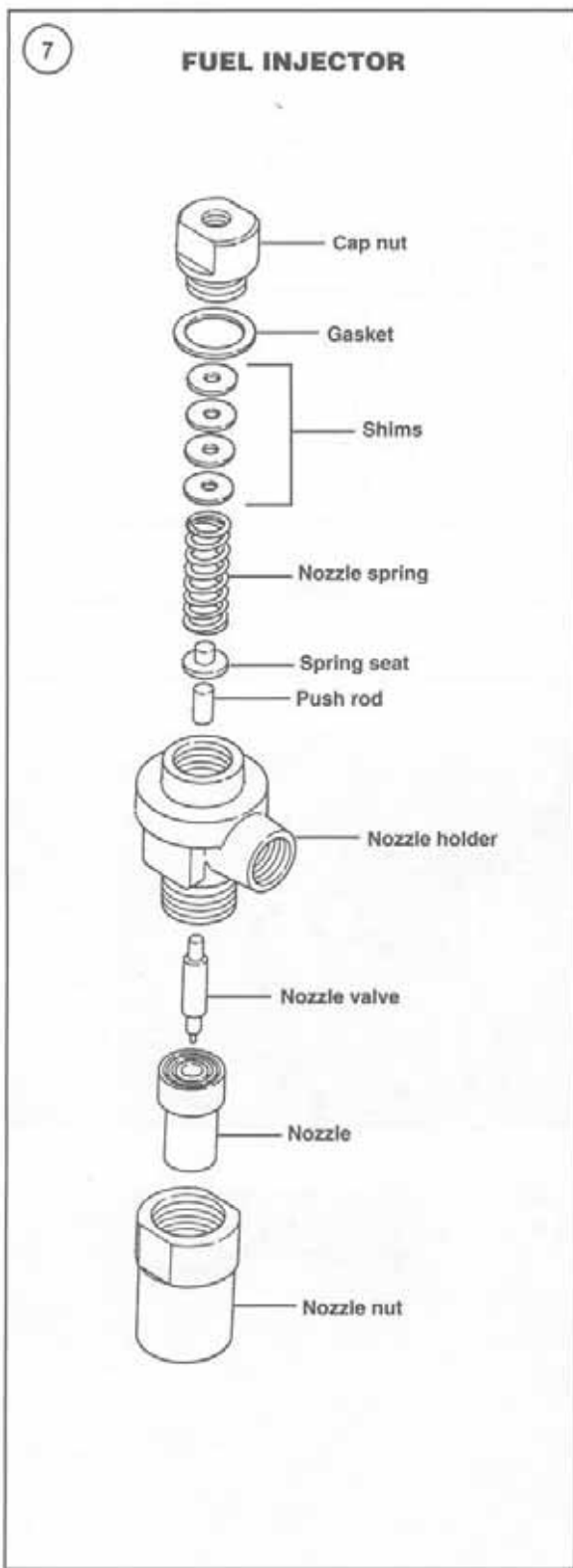

7



5. Loosen the fitting nut (**Figure 12**) on the injector(s) just enough to expel fuel.
6. Move the engine speed control to the full throttle position.
7. Move the decompression lever to the ON position.

NOTE

Do not operate the starter for more than 30 seconds; otherwise the starter may be damaged due to overheating.

8. Operate the starter until air-free fuel flows from the injector(s).
9. Tighten the injector fuel line fitting nut(s) to 20 N·m (15 ft.-lb.).
10. Operate the starter and listen for the distinctive noise that indicates the injector is operating.

FUEL INJECTION TIMING

Similar to ignition timing on a gasoline engine, the fuel must be injected at the proper time to obtain optimum combustion.

Injection timing is determined by the relationship between the injection pump plunger and the injection camshaft in the engine. The rotating cam acts against the roller on the pump plunger in the fuel injection pump (**Figure 13**) to force up the plunger and pump fuel to the injector nozzle. Moving the fuel injection pump up or down on its mounting surface changes the point on the cam that the plunger begins vertical movement, thereby changing when injection occurs.

Shims between the injection pump and its mounting surface on the engine are used to adjust fuel injection timing (**Figure 13**). Increasing shim thickness retards injection timing, while decreasing shim thickness advances injection timing.

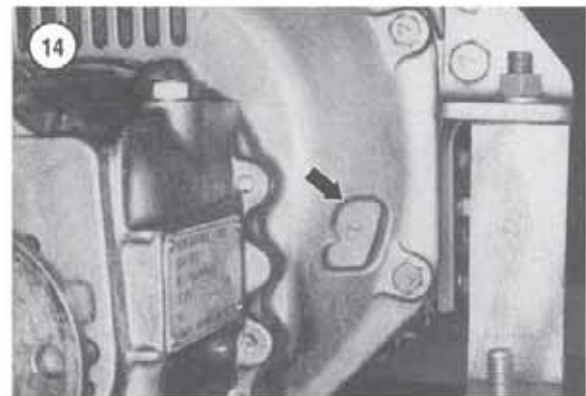
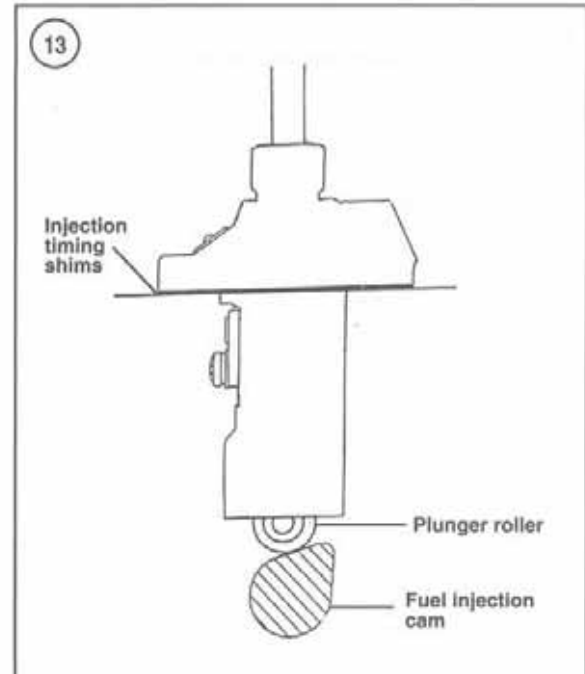

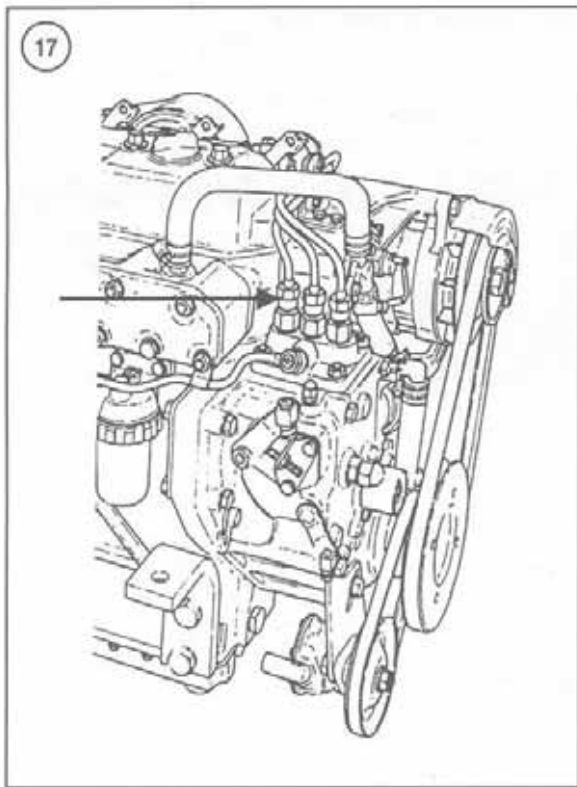
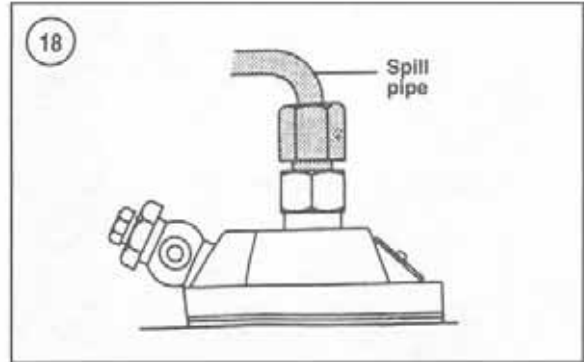
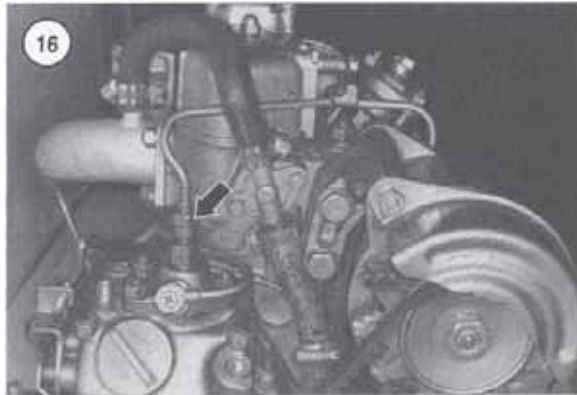

Adjust Fuel Injection Timing

1. Make sure there is no air in the fuel system. If necessary, bleed the fuel system as described in the previous section.
2. If there is no flywheel observation hole in the clutch cover (Figure 14), remove the starter motor so the timing marks on the flywheel (Figure 15) are visible.

- 3A. On 1GM and 1GM10 models—Unscrew the fuel injection line retaining nut (Figure 16) and disconnect the fuel line from the pump.

NOTE

On 2GM, 2GM20, 3GM, 3GM30, 3HM and 3HM35 engines, the cylinder nearest the flywheel is the number one cylinder.

- 3B. On 2GM, 2GM20, 3GM, 3GM30, 3HM and 3HM35 models—Unscrew the fuel injection line retaining nut (Figure 17) for the number one cylinder fuel injection line, then disconnect the fuel line from the pump.

4. Install a spill pipe on the pump in place of the high-pressure fuel line (Figure 18).

NOTE

If a spill pipe is not available or cannot be fabricated, observe fuel flow in the open nipple.

5. Place the speed control lever at the mid-throttle position.

NOTE

Do not use the starter motor when rotating the crankshaft.

NOTE

Always rotate the crankshaft in the normal running direction (clockwise at the crankshaft pulley); otherwise the water pump impeller may be damaged.

6. Rotate the crankshaft with the crankshaft pulley retaining nut until the 1T mark on the flywheel appears.

NOTE

The piston must be on its compression stroke. If fuel does not appear in the spill pipe, the piston may not be on the compression stroke.

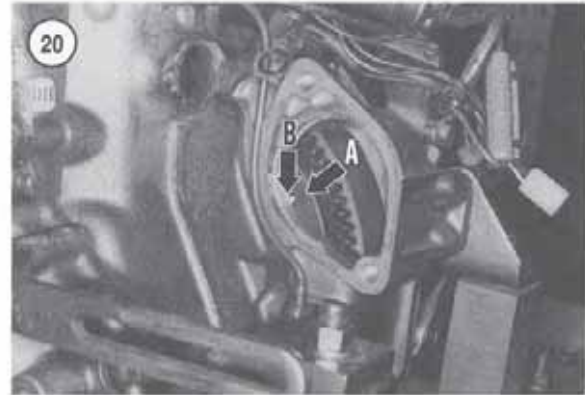
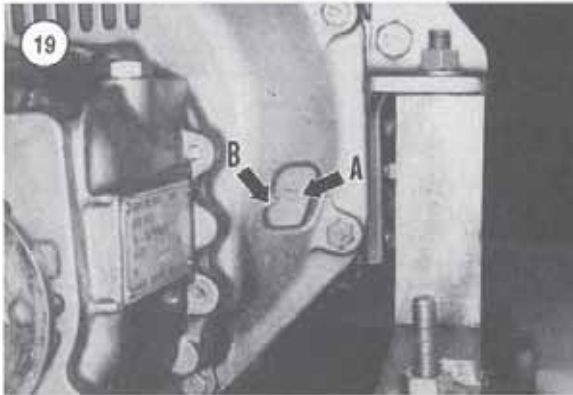

sion stroke. Rotate the crankshaft one full turn.

7. Slowly rotate the crankshaft while observing the fuel in the fuel nipple on the injection pump and the timing marks on the flywheel.
8. When fuel appears in the spill pipe, the injection timing mark on the flywheel (A, **Figure 19**) should align with the reference pointer (B) on the clutch cover. If viewing marks through the starter hole, the injection timing mark on the flywheel (A, **Figure 20**) should align with the reference mark (B) on the clutch cover.

NOTE

There are two timing marks for each cylinder on the flywheel: a mark for top dead center (TDC) and the injection timing mark. The TDC mark is identified by a T next to the mark. Near the TDC mark is another mark, the injection timing mark, which has no identifying letters or numbers. The injection timing mark is to the right of the TDC mark when viewing the mark through the starter hole, or to the left of the TDC mark when viewing the mark through the clutch cover hole.

9. If the injection timing is not correct, remove the fuel injection pump as described in this chapter.
10. Measure the shim pack located between the pump and engine mounting surface (**Figure 21**).
- 11A. *Injection timing retarded*—If injection timing is retarded, decrease the shim thickness to advance injection timing. Decreasing shim thickness 0.1 mm will advance injection timing one degree.
- 11B. *Injection timing advanced*—If injection timing is advanced, increase the shim thickness to retard injection timing. Increasing shim thickness 0.1 mm will retard injection timing one degree.



12. Install the shims and injection pump, then recheck injection timing.
13. On 2GM, 2GM20, 3GM, 3GM30, 3HM and 3HM35 models—Check fuel injection timing for the remaining cylinders. Use the injection timing mark adjacent to the 2T or 3T marks for the cylinder being checked. If injection timing is incorrect for the number two or three cylinders, have a Yanmar dealership or diesel fuel injection shop inspect the injection pump.

FUEL INJECTOR

Each cylinder is equipped with a fuel injector (**Figure 22**). Refer to *Fuel Injector* in the *Fuel Injection Fundamentals* section of this chapter for information regarding fuel injector operation.

Maintaining optimum fuel injector performance is primarily dependent on using clean fuel. Dirt or debris in the fuel is the predominant cause of poor injector performance. The injector is also subject to the heat and byproducts of combustion. The fuel injector nozzle is protected from combustion heat by a heat shield. However, heat and

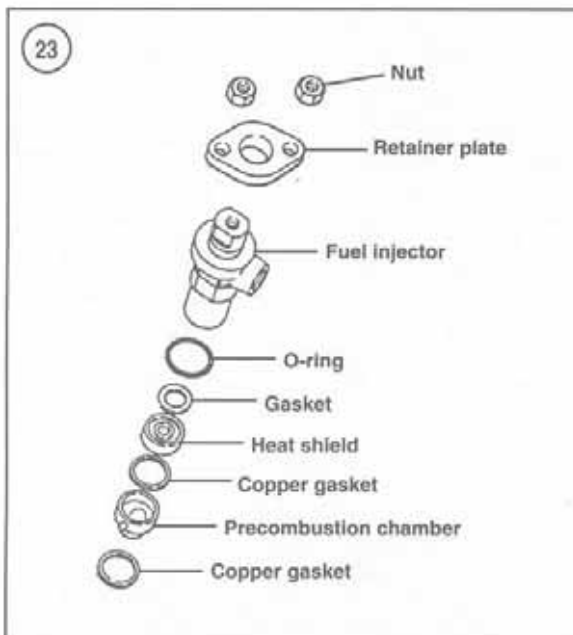
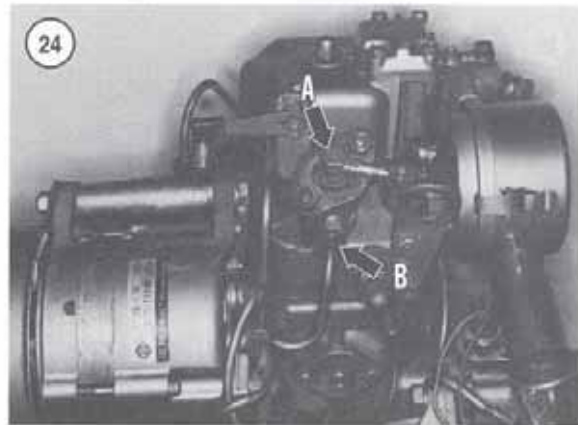

combustion byproducts eventually affect injector operation. Clogging may affect the spray pattern, which may cause misfiring and decreased engine performance. Yanmar does not specify when a fuel injector should be removed for cleaning. A periodic maintenance schedule can be formulated based on when engine performance declines due to the injector becoming clogged. An injector should perform properly for several hundred hours before requiring service; otherwise, operating procedures, fuel type or condition, or another engine problem are responsible for unsatisfactory injector operation.

Injector service should be limited to removal for external cleaning. Have a Yanmar dealership or diesel fuel injection shop perform internal cleaning or overhaul.

Removal and Installation

Refer to **Figure 23** for an exploded view of the fuel injector and precombustion chamber assembly.

1. Thoroughly clean the fuel injector and the area around the injector to make sure debris will not fall into the engine.

NOTE

Plug or cap all fuel openings to prevent the entrance of dirt or debris.

NOTE

Note the location of all washers so they can be returned to their original positions.

2. Detach the fuel return line from the nipple on the fuel injector. On multicylinder engines, the fuel return line must be removed from all injectors. Hold the injector and remove the fuel return line nut (A, **Figure 24**) and return line fitting.
3. If necessary, unscrew the fuel line retaining brackets. Detach the high-pressure fuel line (B, **Figure 24**) from the fuel injector.
4. Unscrew the retainer plate nuts (A, **Figure 25**), then remove the retainer plate (B).
5. Remove the fuel injector (**Figure 26**).
6. Extract the heat shield and gasket (**Figure 27**). The gasket resides in a groove in the top of the heat shield.

NOTE

Do not damage the precombustion chamber when removing it in Step 7 if it is tight in the cylinder head. If necessary, remove the cylinder head to dislodge the precombustion chamber.

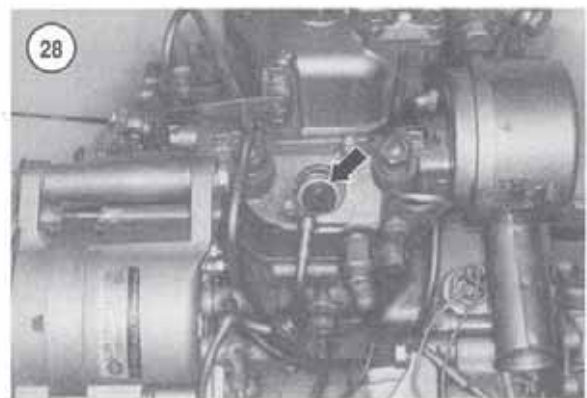
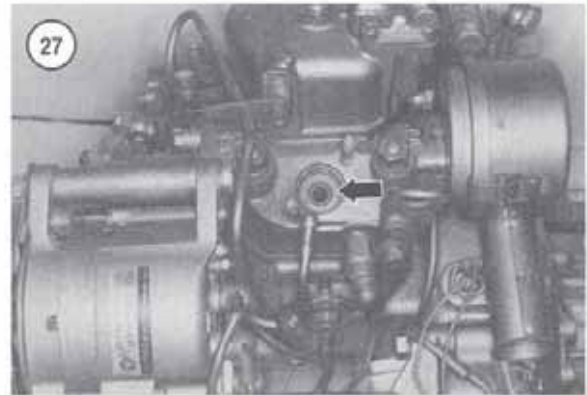
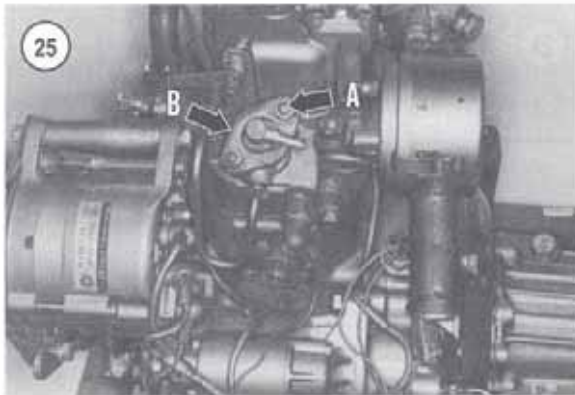

7. Extract the precombustion chamber and copper gaskets (Figure 28). Note that there is a copper gasket (Figure 29) above and below the chamber; make sure to remove the bottom gasket after removing the chamber.

8. On models so equipped, remove and discard the O-ring on the fuel injector (Figure 23).

9. Plug the opening in the cylinder head to prevent the entry of dirt or debris.

10. Refer to the following section for injector testing and cleaning information.

11. Inspect the precombustion chamber. If damaged, discard the chamber. Clean the heat shield.

12. Discard the gaskets and install new gaskets. Thoroughly remove any gasket residue in the top of the heat shield.

13. Install the bottom copper gasket in the injector bore in the cylinder head.

14. Install the precombustion chamber with the holes toward the cylinder head. Align the pin on the side of the precombustion chamber (Figure 30) with the groove in the injector bore (Figure 31).

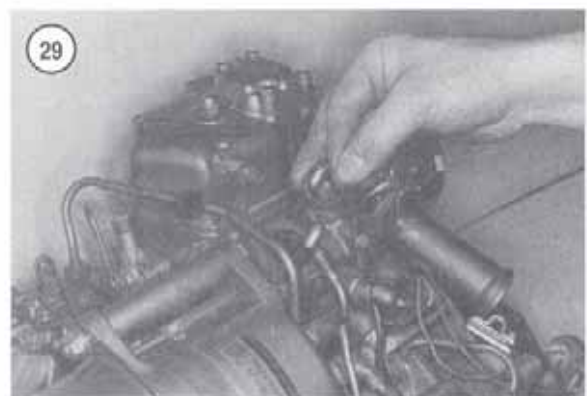

15. Install the upper copper gasket onto the precombustion chamber.

16. Install the heat shield and gasket. The open side of the heat shield must be down.

17. Install the O-ring onto the fuel injector (Figure 29).

18. Install the fuel injector into the injector bore in the cylinder head (Figure 26).

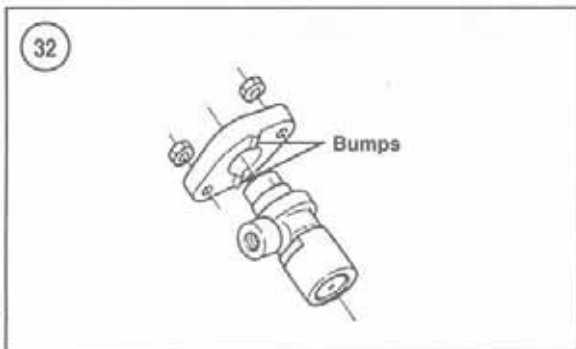
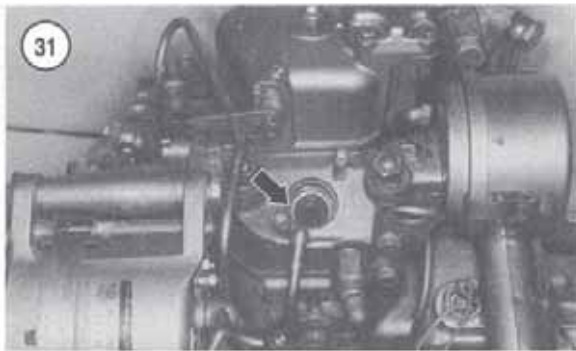

19. Connect the high-pressure fuel line to the injector.
20. Install the retainer plate so the side with bumps (Figure 32) is down and contacts the injector.
21. Install the retaining nuts. Tighten the nuts evenly to 20 N•m (14.5 ft.-lb.).
22. Connect the fuel return line.
23. Reattach fuel line retaining brackets.
24. Bleed the fuel injection system as described in this chapter. Run the engine and check for leaks.

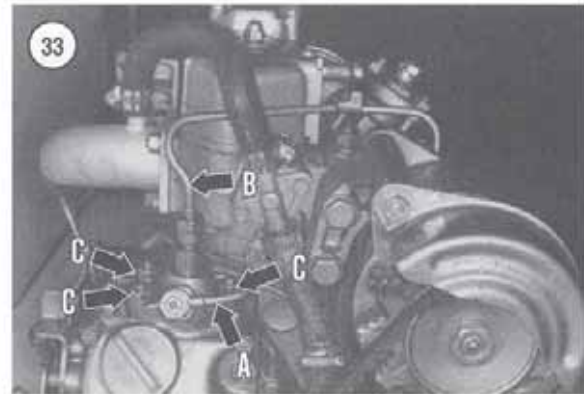

FUEL INJECTION PUMP

7

The fuel injection pump is built to precise specifications and is easily damaged by contamination from dirt or debris. Due to the close tolerances in the pump and the special tools and equipment required for overhaul and testing, have a Yanmar dealership or diesel fuel injection shop perform any unnecessary service.

Removal and Installation

WARNING

Serious fire hazards always exist around diesel fuel. Do not allow any smoking in areas where fuel is present. Always have a fire extinguisher, rated for fuel and electrical fires, on hand when servicing any part of the fuel system.

1. Close the fuel shutoff valve.
2. Thoroughly clean the fuel injection pump and the area around the pump of all debris.

NOTE

Plug or cap all fuel openings to prevent the entrance of debris.

3. Detach the fuel supply line from the fuel injection pump (A, Figure 33).
4. Unscrew the fuel line retaining brackets. Remove the fuel injection line(s) between the fuel injection pump and fuel injector(s) (B, Figure 33).
5. Remove the injection pump retaining nuts (C, Figure 33).

NOTE

Removing the oil fill cap on 1GM and 1GM10 models provides access to the gov-



ernor linkage for easier pump removal and installation.

6. Lift the injection pump out of the engine while carefully disengaging the governor linkage from the pump.
7. Remove the timing shims (Figure 34) and set them aside for reinstallation.
8. To reinstall the injection pump, reverse the removal procedure. Make sure to reinstall the timing shims and engage the control rack pin (Figure 35) with the governor lever fork. Tighten the pump retaining nuts to 25 N•m (18 ft.-lb.). Bleed the fuel injection system as previously described. Run the engine and check for leaks.

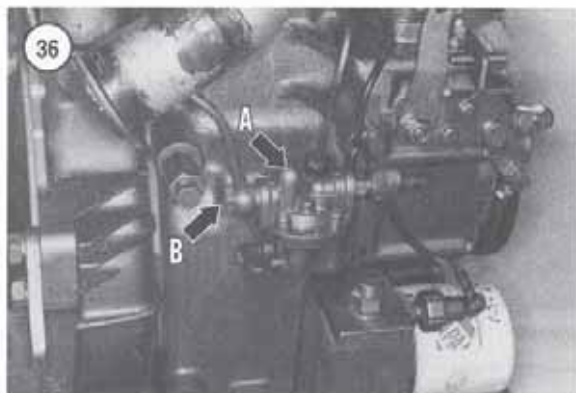

FUEL TRANSFER PUMP

The engine is equipped with a fuel transfer pump (A, Figure 36) to move fuel from the fuel tank to the fuel filter and fuel injection pump. A cam lobe on the engine camshaft operates the pump lever (Figure 37), which moves the fuel pump diaphragm to pump the fuel. Fuel pump pressure is approximately 9.7 kPa (1.4 psi).

The transfer pump output port on 1GM and 1GM10 engines is on the left side with the pump mounted on the engine. On all other engines, the output port is on the right side.

Fuel Pump Testing

WARNING

Always have a fire extinguisher, rated for fuel and electrical fires, on hand when servicing any part of the fuel system. Clean up any spilled fuel as soon as possible.

1. Loosen the air bleed screw (Figure 38) on the fuel filter.

2. Operate the engine starter. If the fuel transfer pump is operating properly, fuel will flow from the air bleed screw hole.
3. If fuel does not flow from the air bleed screw hole, disconnect the output fuel line (B, Figure 36) from the fuel pump.

NOTE

Be prepared to catch fuel expelled from the pump.

4. Operate the engine starter. If fuel does not flow from the fuel pump, replace the pump.

Removal and Installation

1. Close the fuel tank valve.

NOTE

Account for the sealing washers on the fuel hose ends.

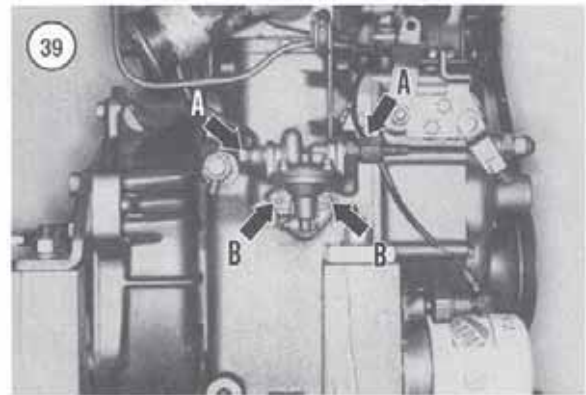
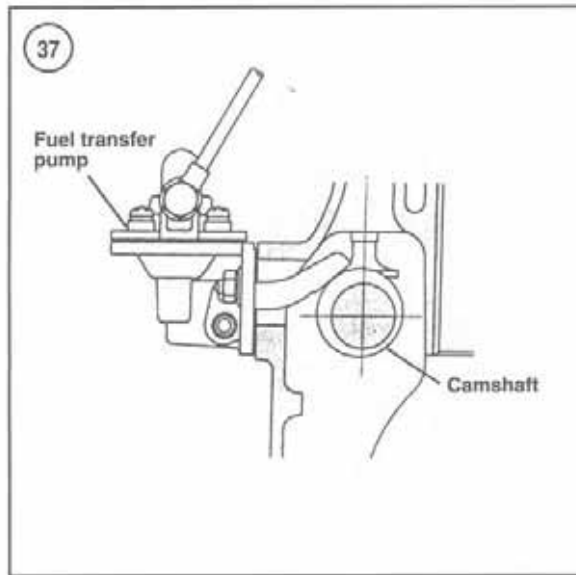

2. Disconnect the fuel lines (A, **Figure 39**) from the fuel transfer pump.
3. Remove the fuel pump retaining bolts (B, **Figure 39**), and then remove the pump.
4. Clean any gasket material from the engine and the fuel pump.
5. Reverse the removal procedure to install the fuel transfer pump. Bleed the fuel injection system as described in this chapter.

NOTE

The transfer pump output port on IGM and IGM10 engines is on the left side with the pump mounted on the engine. On all other engines, the output port is on the right side.

Overhaul

Internal parts for the fuel transfer pump are not available. Replace a defective pump; do not attempt to overhaul it.

7

FUEL LINES

The fuel system utilizes both rubber and steel lines. When replacing fuel lines, use only lines recommended by the manufacturer or a diesel engine shop. Purchase the formed steel fuel lines from a Yanmar dealership. If necessary, a diesel fuel injection shop can fabricate fuel lines. All lines must be secured by brackets to prevent fractures or splitting due to vibration.

Inspection

Periodically inspect the fuel lines for leaks and damage, such as dented or bent steel lines, or cut or abraded rubber lines. Leaks may be due to loose fittings or damage. Tighten loose fittings and recheck the leak after operating the engine. Do not overtighten a fitting to try to stop a leak; overtightening may damage the fitting threads or the fuel line sealing surfaces. If tightening does not stop the leak, disassemble the fuel line and inspect the line and seat to determine the cause of the leak. If sealing surfaces are damaged, replace the fuel line and, if necessary, the fuel fitting or component.

NOTE

Always operate the engine and check for leaks after reconnecting the fuel lines.

Fuel lines with banjo fittings (A, **Figure 40**) are equipped with copper sealing washers (B) on both sides of the fitting. Copper washers harden with age and will not

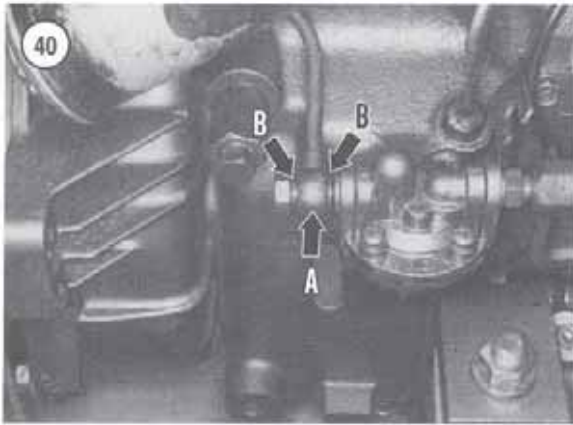

seal properly if reused. Always install *new* washers when reconnecting a fitting.

The fuel lines are secured with brackets to prevent leaks due to engine vibration. Periodically check that fuel lines are properly secured with brackets. The high-pressure fuel injection lines are held by a rubber pad in the bracket (**Figure 41**). Replace any rubber pads that are missing or no longer holding the line securely.

GOVERNOR SYSTEM

Operation

The governor components are in the timing gearcase (**Figure 42**, typical). The purpose of the governor system is to maintain engine speed regardless of the load imposed.

The mechanical governor system utilizes centrifugal force to monitor and adjust engine speed. Refer to **Figure 43**, **Figure 44** and **Figure 45**. A set of flyweights are mounted on the crankshaft. When engine speed increases, the flyweights are thrown out. When engine speed decreases, the flyweights recede. Trapped between the flyweights is a flanged sleeve that moves in and out with the flyweights, pushing against a forked governor arm. The forked governor arm transfers motion to the governor lever, which is connected to the fuel injection pump fuel control rack. The governor spring tension forces the speed control lever against the governor lever, which forces the injection pump speed control rack to the full open throttle position. When load on the engine increases and engine speed decreases, the governor sleeve is withdrawn, which through the linkage moves the speed control rack to increase fuel injection. When load on the engine decreases and engine speed increases, the governor sleeve extends, which moves the linkage to overcome governor spring

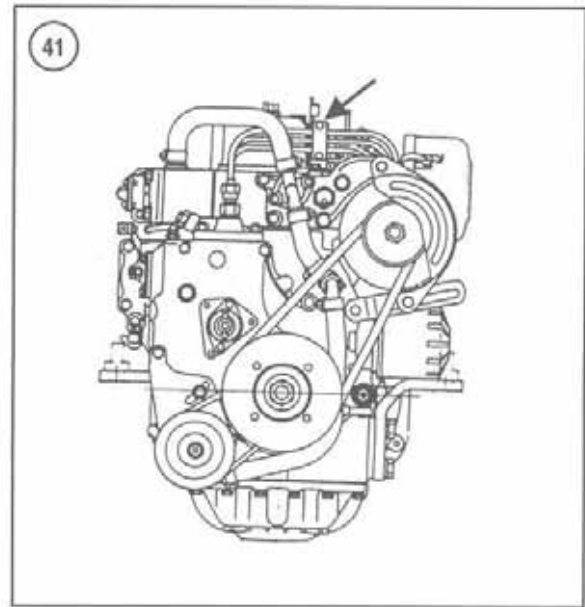

tension. The linkage moves the speed control rack and decreases fuel injection.

The governor controls engine speed in an operating range between idle speed and maximum governed speed. Maximum governed speed is critical as it sets the upper limit of engine operation. Exceeding the maximum governed speed can cause overspeeding, which may result in engine failure.

A fuel limiter screw sets maximum injection pump fuel delivery. When the governor senses a decrease in engine speed, the fuel control rack moves to the full fuel position. The factory-adjusted fuel limiter screw stops the governor linkage at a point that provides maximum, but not excessive, fuel delivery to the engine.

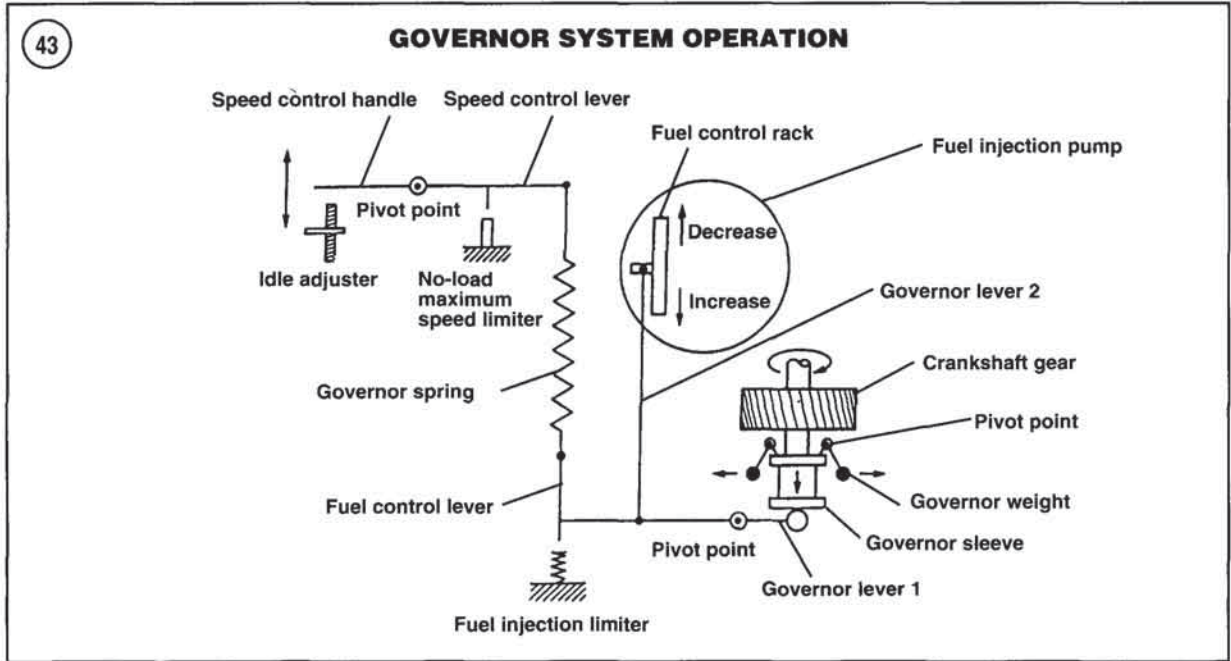

7

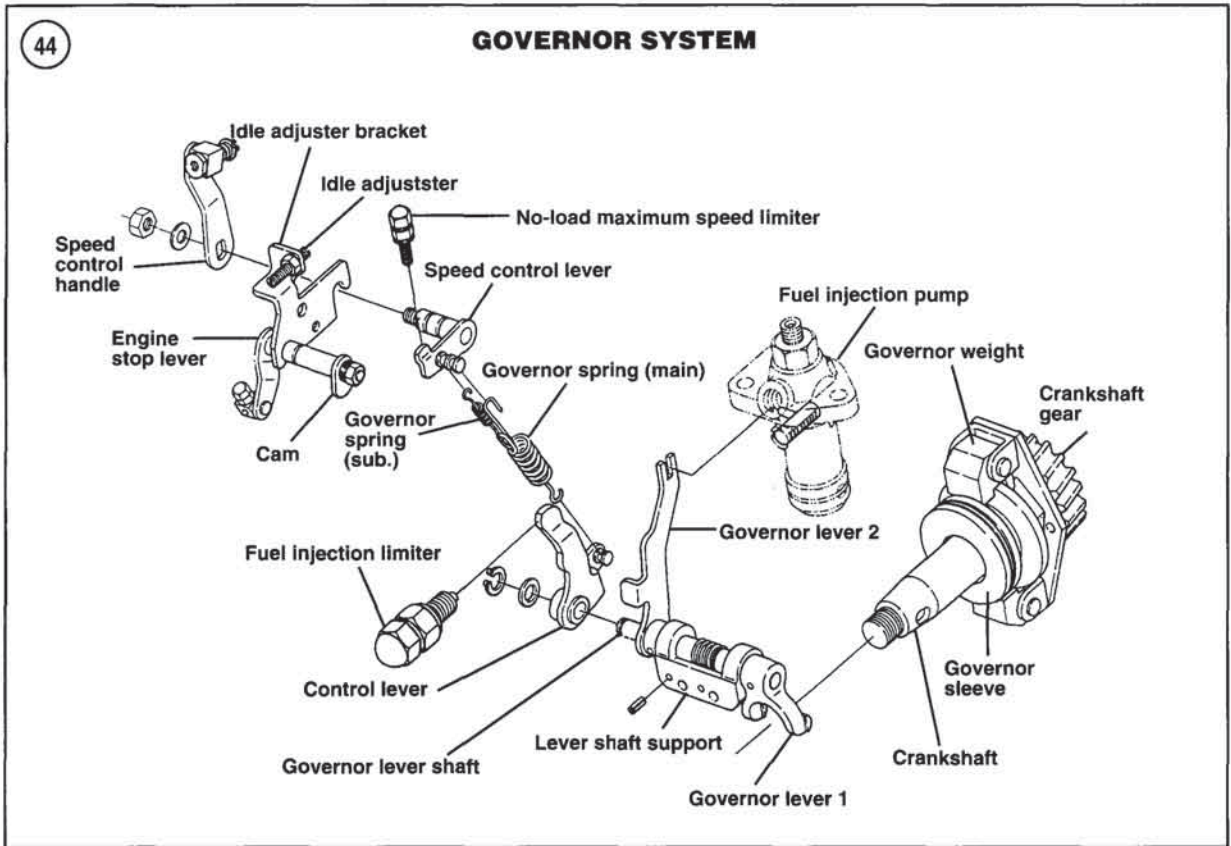

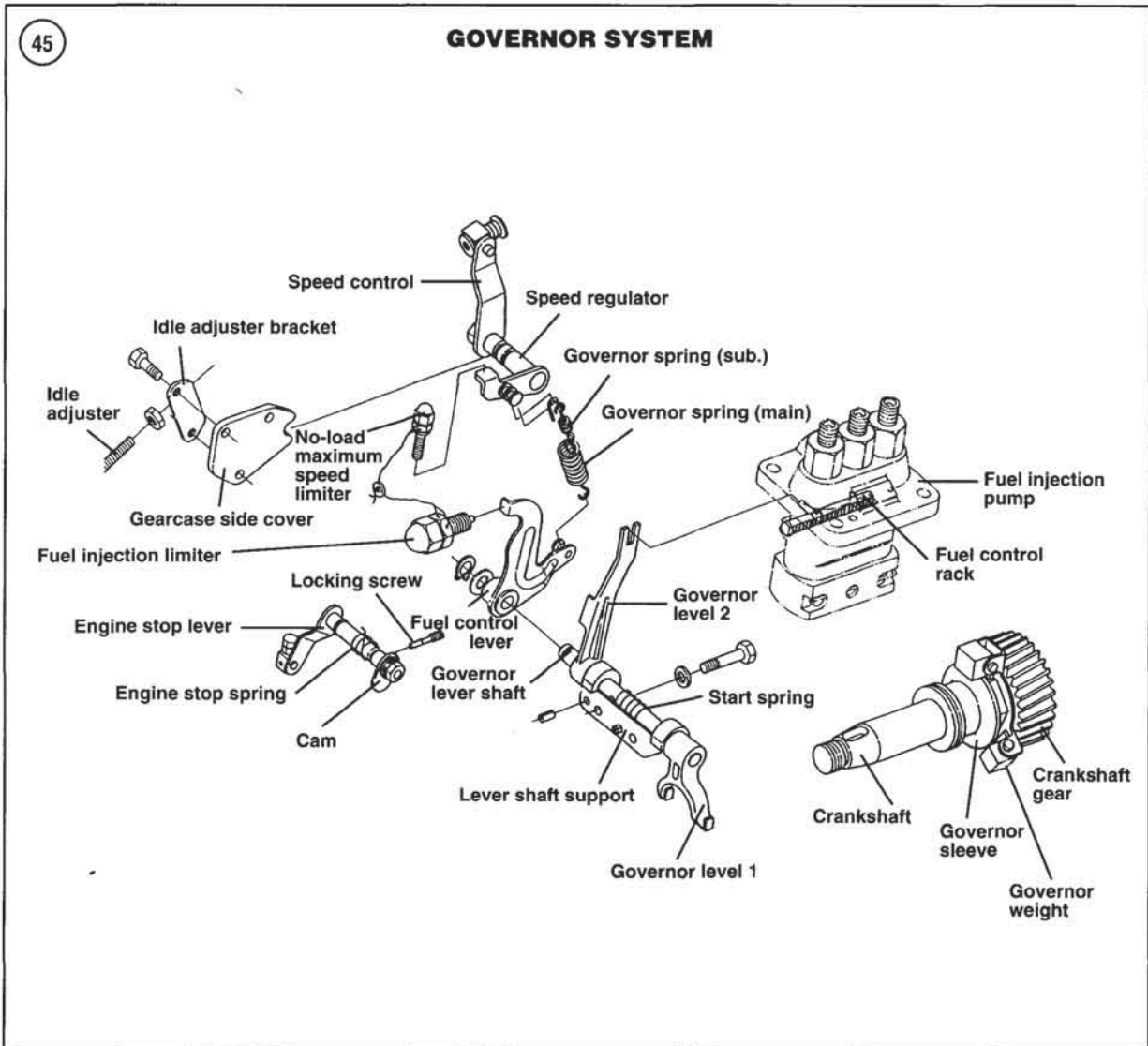

Adjustments

Yanmar recommends that only idle speed adjustment should be performed by non-authorized service technicians. Refer to Chapter Three for the idle speed procedure.

Other adjustments, such as no-load maximum governed speed and fuel limiter screw setting, are set by the manufacturer. Incorrect adjustment can damage the engine. To prevent tampering, a safety wire is attached to each screw and a lead seal is affixed to the wire or the screw assembly is marked (**Figure 46**). Removing or cutting the wire or seal or altering the marked screw position will void the engine warranty.



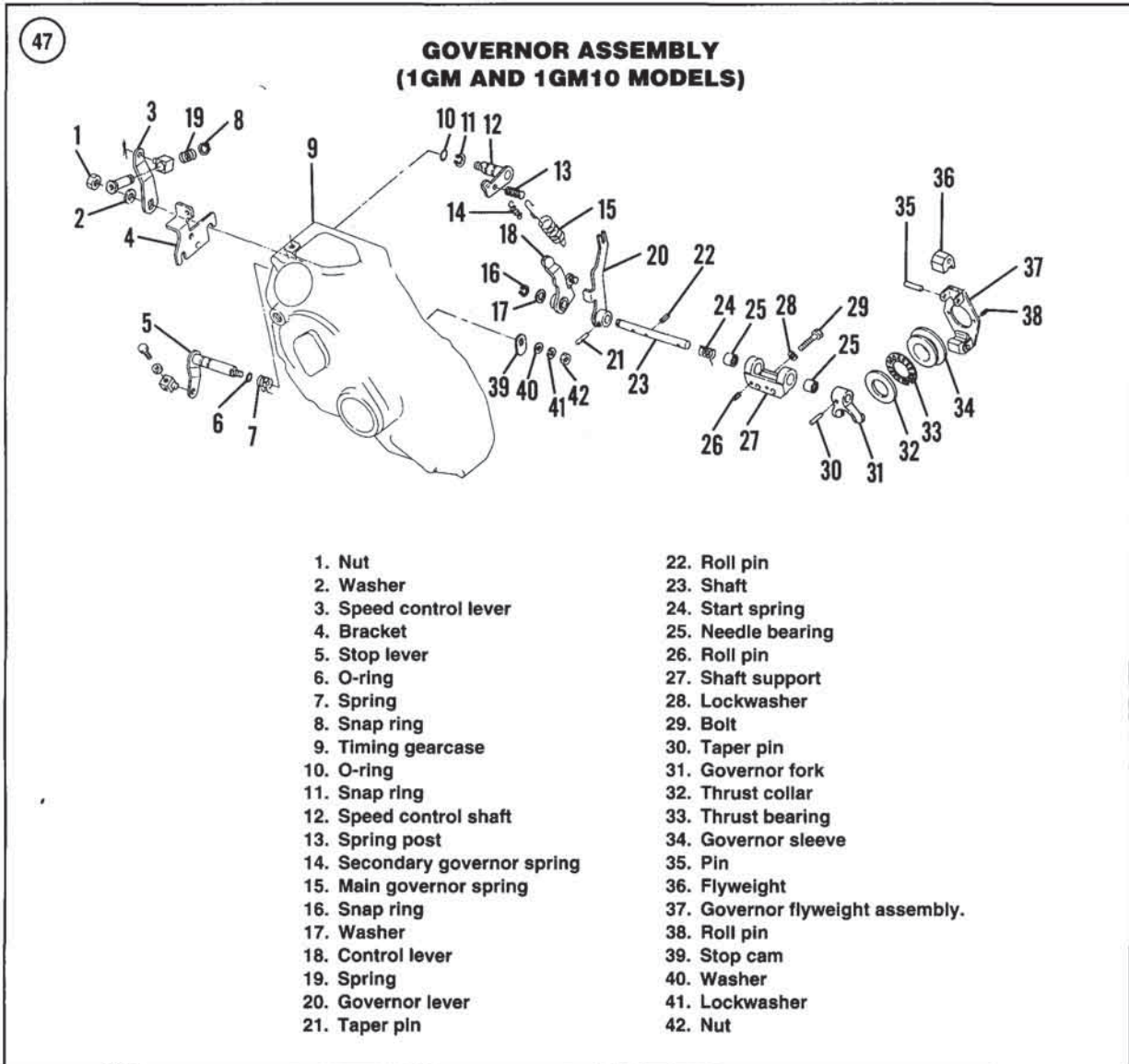

7

Removal/Inspection/Installation

The governor components are contained in the timing gearcase (Figure 42, typical). Refer to Figure 47 or Figure 48 for an exploded view of the governor mechanism.

1. Remove the timing gearcase as described in Chapter Five or Six.

2. Carefully disconnect the governor spring (15, Figure 47 or Figure 48).

3. Check the governor shaft assembly for damage or looseness. Excessive play can cause improper governor operation. The shaft rides in bearings and should rotate smoothly without binding. The pinned levers should be tight on the shaft.

NOTE
Do not distort or damage the governor spring.

NOTE
Tapered pins secure the levers to the shaft. Remove a pin by driving against the small end of the pin.

48

**GOVERNOR ASSEMBLY
(2GM, 2GM20, 3GM, 3GM30, 3HM AND 3HM35 MODELS)**

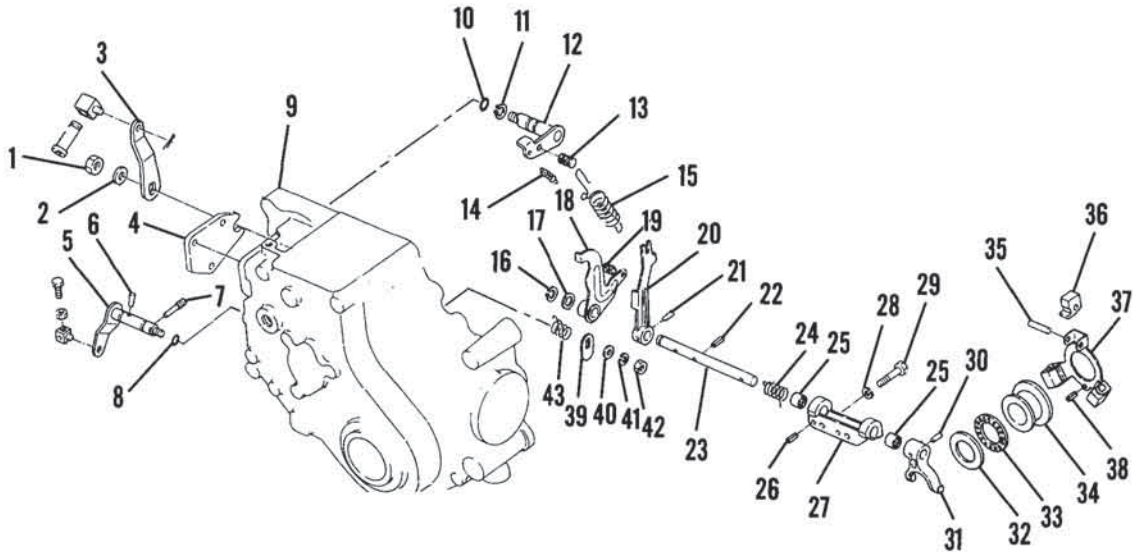

- | | |
|-------------------------------|----------------------------------|
| 1. Nut | 23. Shaft |
| 2. Washer | 24. Start spring |
| 3. Speed control lever | 25. Needle bearing |
| 4. Bracket | 26. Roll pin |
| 5. Stop lever | 27. Shaft support |
| 6. Taper pin | 28. Lockwasher |
| 7. Lock screw | 29. Bolt |
| 8. O-ring | 30. Taper pin |
| 9. Timing gearcase | 31. Governor fork |
| 10. O-ring | 32. Thrust collar |
| 11. Snap ring | 33. Thrust bearing |
| 12. Speed control shaft | 34. Governor sleeve |
| 13. Spring post | 35. Pin |
| 14. Secondary governor spring | 36. Flyweight |
| 15. Main governor spring | 37. Governor flyweight assembly. |
| 16. Snap ring | 38. Roll pin |
| 17. Washer | 39. Stop cam |
| 18. Control lever | 40. Washer |
| 19. Spring post | 41. Lockwasher |
| 20. Governor lever | 42. Nut |
| 21. Taper pin | 43. Spring |
| 22. Roll pin | |

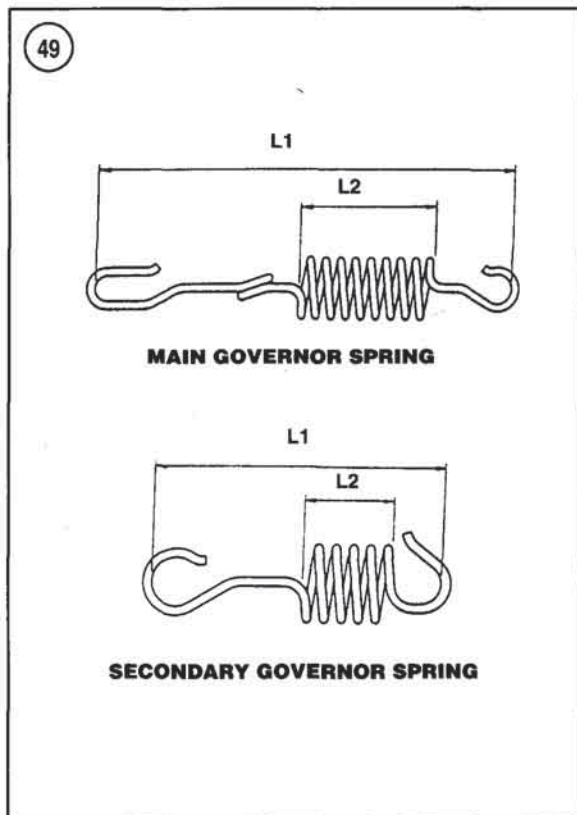

4. If disassembly of the governor shaft assembly is required, remove the retaining bolts (29, **Figure 47** or **Figure 48**) and remove the shaft assembly. To disassemble the components, detach the snap ring (16), then drive out the tapered pins that retain the levers. Replace the worn parts.

5. Remove the idle adjuster bracket and side cover (4, **Figure 47** or **Figure 48**).

6. Check the speed control lever and shaft (12, **Figure 47** or **Figure 48**) for excessive play between the shaft and the timing gearcase and between the lever and the shaft.

- a. If the shaft is loose in the timing gearcase, remove the nut (1, **Figure 47** or **Figure 48**), then remove the speed control lever (3). Remove the shaft (12) and determine if the shaft, the timing gearcase or both are worn. Replace or repair the worn part.
- b. If the lever is loose on the shaft, remove the nut (1, **Figure 47** or **Figure 48**), then remove the speed control lever (3). Determine if the lever, the shaft or both are worn. Replace any worn parts.

7A. On 1GM and 1GM10 models—Check the stop shaft (5, **Figure 47**) for excessive play between the shaft and the timing gearcase. If excessive play is evident, remove

the nut (42), then withdraw the shaft. Determine if the shaft, the timing gearcase or both are worn. Replace or repair any worn parts.

7B. On 2GM, 2GM20, 3GM, 3GM30, 3HM and 3HM35 models—Check the stop shaft (5, **Figure 48**) for excessive play between the shaft and the timing gearcase. If excessive play is evident, drive out the taper pin (6) by driving against the small end of the pin. Remove the locking screw (7). Remove the nut (42), then remove the shaft. Determine if the shaft, the timing gearcase or both are worn. Replace or repair any worn parts.

8. Inspect the governor springs for damage and distortion. Measure the length of the main and secondary governor springs as shown in **Figure 49**. Replace either spring if its free length dimension is not as specified in **Table 2**. If either spring is questionable, take it to a Yanmar dealership for testing.

9. Remove and inspect the thrust collar (32, **Figure 47** or **Figure 48**). Replace the thrust collar if damaged or if the thickness is less than 2.9 mm (0.114 in.).

10. Remove the thrust bearing (33, **Figure 47** or **Figure 48**). Replace the bearing if damaged.

11. Remove the governor sleeve (34, **Figure 47** or **Figure 48**). Inspect the governor sleeve and crankshaft for damage. Refer to the specifications in **Table 3**.

12. Check the operation of the flyweight assembly (37, **Figure 47** or **Figure 48**). The flyweights should move smoothly without excessive looseness. The contact surface in the flyweight groove should not be excessively worn. The flyweight assembly must be replaced as a complete assembly. Remove the crankshaft nut as described in Chapter Five or Six to remove the flyweight assembly.

13. Reassemble the governor assembly by reversing the disassembly procedure while noting the following:

- a. Do not distort the governor springs during installation.
- b. Install the governor springs so the long hook end engages the speed control lever (12, **Figure 47** or **Figure 48**).
- c. Install the secondary governor spring (14, **Figure 47** or **Figure 48**) so the lower end of the spring fits in the loop on the main governor spring.
- d. Note that the pins securing the levers on the shafts are tapered. The lever should fit tightly on the shaft after the pin is installed. If not, replace the worn part.
- e. Check the movement of all the parts after assembly. Motion should be smooth without binding.

14. Reinstall the timing gearcase as described in Chapter Five for single cylinder engines or Chapter Six for multi-cylinder engines.

Table 1 TIGHTENING TORQUES

Fastener	N•m	ft.-lb.	in.-lb.
Injector fuel nut	20	15	—
Injection pump retaining nuts	25	18	—

Table 2 GOVERNOR SPRING FREE LENGTH

	1GM, 1GM10	2GM, 2GM20	3GM, 3GM30, 3HM, 3HM35
Main governor spring			
L1	76 mm (2.99 in.)	78 mm (3.07 in.)	78 mm (3.07 in.)
L2	18 mm (0.71 in.)	20 mm (0.79 in.)	20 mm (0.79 in.)
Secondary governor spring			
L1	26 mm (1.02 in.)	23 mm (0.90 in.)	23 mm (0.90 in.)
L2	5 mm (0.20 in.)	10 mm (0.39 in.)	10 mm (0.39 in.)

Table 3 GOVERNOR SLEEVE AND CRANKSHAFT SPECIFICATIONS

Governor sleeve inside diameter	25.053-25.083 mm (0.9863-0.9875 in.)
Governor sleeve length—wear limit	14.8 mm (0.583 in.)
Crankshaft diameter	24.972-24.993 mm (0.9831-0.9840 in.)
Governor sleeve clearance on crankshaft	0.060-0.111 mm (0.0024-0.0044 in.)
Maximum allowable clearance	0.20 mm (0.008 in.)