

# **MARINE DIESEL ENGINE**

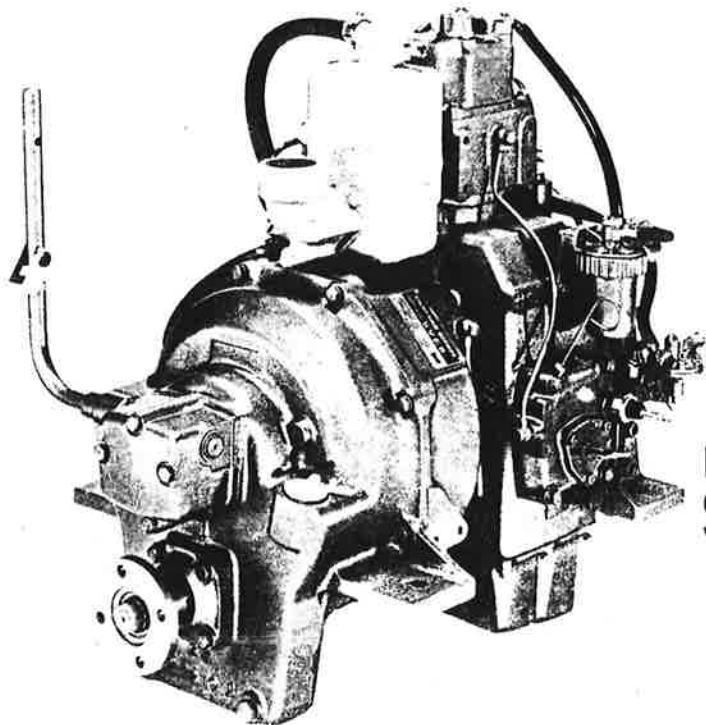

MODEL  
**SVE** series

# CONTENTS

I.	SUMMARY OF ENGINE . . . . .	3
1-1	Engine Specifications . . . . .	3
1-2	Performance Curves . . . . .	4
1-3	Flow Diagrams . . . . .	6
1-3-1	Cooling Water Diagram . . . . .	6
1-3-2	Lube Oil Diagram . . . . .	6
1-3-3	Fuel Diagram . . . . .	7
1-3-4	Electrical Wiring Diagram . . . . .	8
1-3-5	Gear Train . . . . .	9
1-3-6	Marine Gear . . . . .	10
1-4	Piping Diagram . . . . .	12
1-5	Outside View . . . . .	13
1-6	Use of Front PTO Device . . . . .	14
1-7	Remote Control . . . . .	16
1-8	Accessories . . . . .	17
2.	MAINTENANCE AND INSPECTION . . . . .	19
2-1	Fuel Oil and Lubricant . . . . .	19
2-2	Pointers for Maintenance . . . . .	21
2-3	Normal Operation . . . . .	23
2-4	Periodic Check Table . . . . .	24
2-5	Periodic Checks . . . . .	26
3.	ALIGNMENT OF ENGINE . . . . .	29
3-1	Tools for Overhaul and Reassembling . . . . .	29
3-2	Engine Adjustment Specifications . . . . .	31
3-3	Measurements of Major Components . . . . .	32
3-3-1	Cylinder Liner . . . . .	32
3-3-2	Thrust Metal . . . . .	34
3-3-3	Height of Cylinder Head Tightening Bolt . . . . .	35
3-3-4	Crankshaft and Bearing . . . . .	35
3-3-5	Cam Shaft and Tappet . . . . .	39
3-3-6	Piston, Piston ring and Piston pin . . . . .	40
3-3-7	Connecting rod . . . . .	42
3-3-8	Valve Mechanism: Valve Seat . . . . .	44
	Valve and Guide . . . . .	44
	Valve Spring . . . . .	44
	Rocker Arm . . . . .	45

3-3-9	Fuel Injection Pump and Nozzle . . . . .	45
3-3-10	Cooling Water Pump . . . . .	46
3-3-11	Friction Disc and Reduction gear . . . . .	46
3-3-12	Fuel Oil Feed Pump . . . . .	47
3-3-13	Lube Oil Pump . . . . .	47
3-4	Bolts, Nuts and Tightening Torques . . . . .	48
3-5	Disassembly and Reassembly of Engine . . . . .	49
3-5-1	General Precautions . . . . .	49
3-5-2	Disassembly Sequence . . . . .	50
3-5-3	Reassembly Sequence . . . . .	58
3-5-4	Disassembly and Reassembly of Major Components: . . . . .	62
	Clutch ass'y . . . . .	62
	Fuel Injection Pump . . . . .	67
	Fuel Injection Valve . . . . .	70
	Cooling Water Pump . . . . .	71
4.	ADJUSTMENT . . . . .	71
4-1	Air Bleeding . . . . .	71
4-2	Fuel Injection Pump:      Fuel Injection Timing . . . . .	72
	Fuel Injection Quantity . . . . .	73
4-3	Fuel Injection Valve . . . . .	73
4-4	Adjustment of Intake/Exhaust Valve Clearances . . . . .	74
4-5	Adjustment of Governor Linkage . . . . .	75
5.	ELECTRICAL EQUIPMENT . . . . .	77
5-1	Starter Motor . . . . .	77
5-2	AC Generator . . . . .	85
5-3	Reference Data (for diodes) . . . . .	90
6.	TROUBLES AND COUNTERMEASURES . . . . .	91
6-1	Major Classification of Troubles . . . . .	91
6-2	Difficult Starting . . . . .	91
6-3	Disordered Running . . . . .	101
6-4	Sudden Stop of Engine . . . . .	116
6-5	Oil, Water or Gas Leakage . . . . .	119
7.	STORAGE OF ENGINE . . . . .	120

# 1. SUMMARY OF ENGINE

## 1-1. Engine Specifications

Model			SVE 8	SVE8G	SVE12	SVE12G
Type			Vertical, 4-cycle water-cooled diesel engine			
Combustion Chamber			Swirl type precombustion chamber			
Number of Cylinders			1			
Bore x stroke		mm	75 x 75		85 x 90	
Displacement		ℓ	0.331		0.510	
Continuous rating DIN. A	Output/engine speed	HP/rpm	7/3200		10/3000	
	Propeller shaft speed	rpm	1524	1051	1429	986
	BMEP	Kg/cm <sup>2</sup>	5.95		5.88	
	Mean piston speed	m/s	8.0		9.0	
One hour rating DIN. B	Output/engine speed	HP/rpm	8/3200		12/3000	
	BMEP	Kg/cm <sup>2</sup>	6.80		7.06	
	Mean piston speed	m/s	8.0		9.0	
Compression ratio			23.1		20.9	
Dry weight (chain starting)			130 (125)		160 (155)	
Direction of rotation	Propeller shaft		Clockwise viewed from clutch side			
	P.T.O.s shaft		Clockwise viewed from P.T.O. shaft			
Cooling system			Forced cooling by rotary rubber pump			
Lubricating system			Forced lubrication by trochoid pump			
Starting system			Electric with manual starters or chain starter			
Reduction gear system			Spur gear single reduction type			
Clutch system			Mechanical clutch (wet, single disk plate type)			
Reduction ratio	Ahead		2.10:1	3.04:1	2.10:1	3.04:1
	Astern		1.80:1	2.48:1	1.80:1	2.48:1
Engine size	Overall length	mm	629		662	
	Overall width (chain starting)	mm	Max. 495 (443)		Max. 520 (471)	
	Overall height	mm	607		678	
Lube oil capacity (Rake angle 8 degree)	Engine side	Total	ℓ	2.8		3.5
		Effective	ℓ	1.2		2.1
	Clutch side	Total	ℓ	0.5		0.5
		Effective	ℓ	0.2		0.2

## 1-2. Performance Curves

Model SVE8(G)

- 1 Continuous output "B" DIN 6270
- 2 Continuous output "A" DIN 6270
- 3 Propeller power

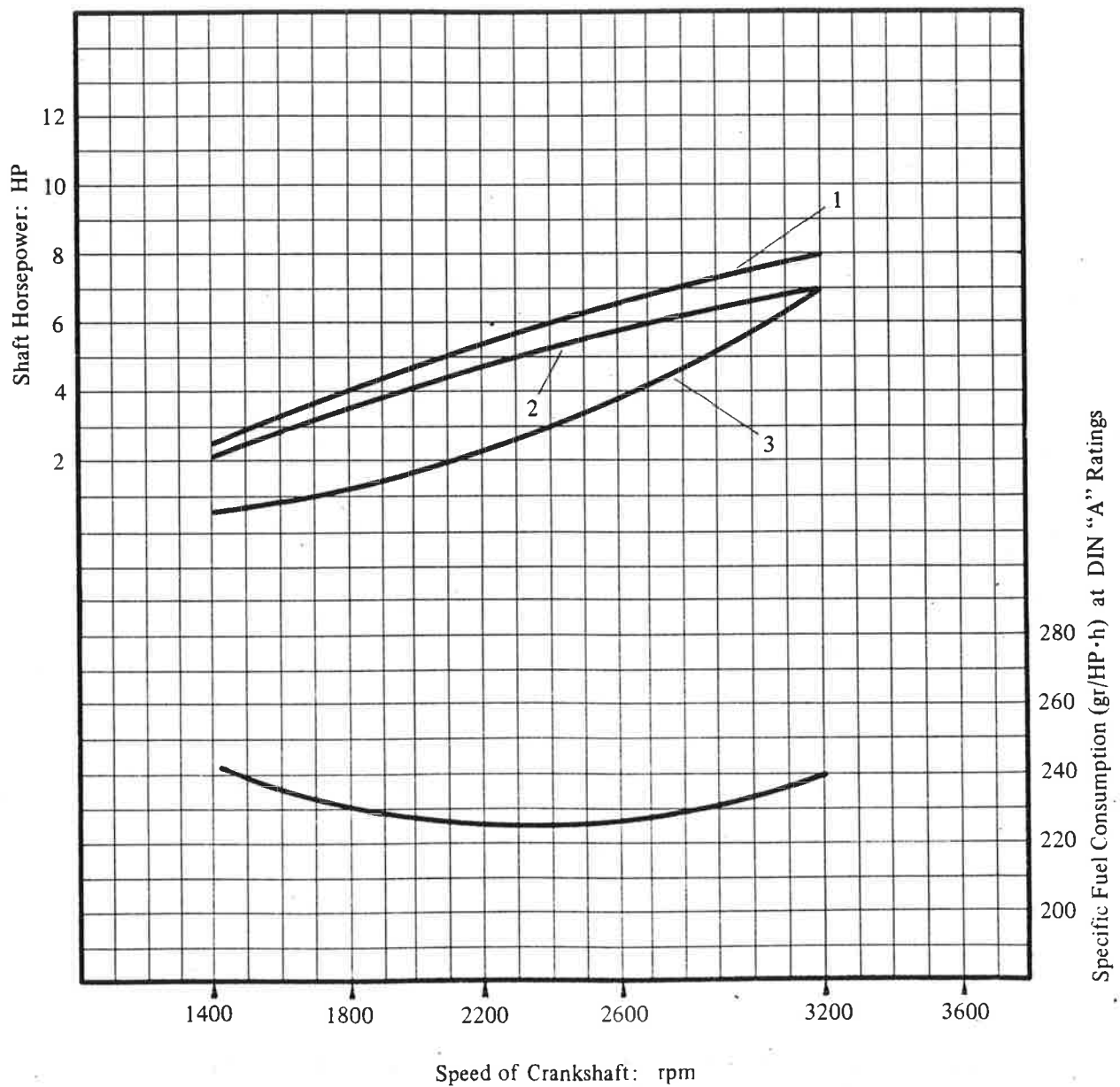

Model SVE12(G)

- 1 Continuous output "B" DIN 6270
- 2 Continuous output "A" DIN 6270
- 3 Propeller power

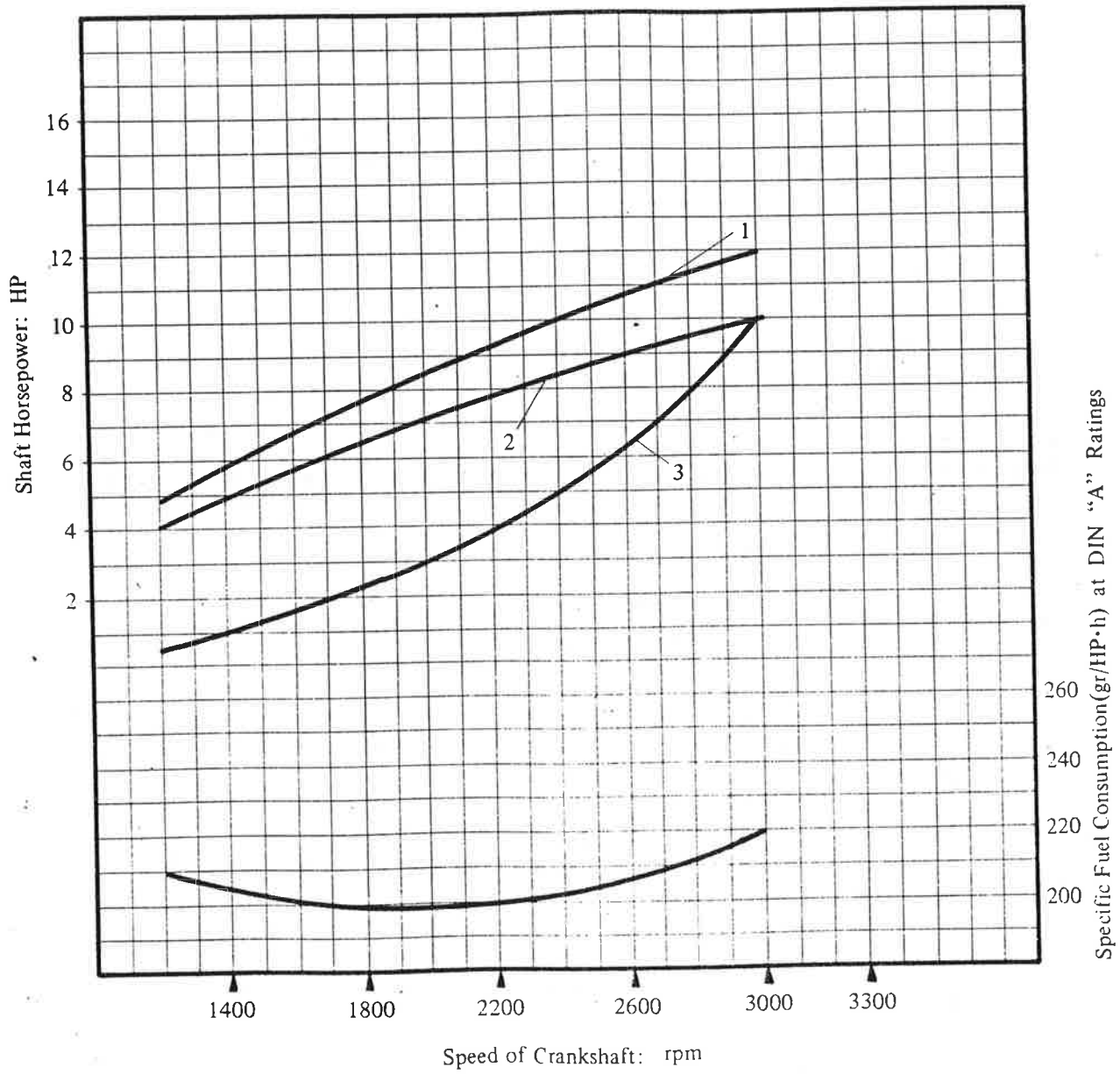

1-3. Flow Diagrams

1-3-1. Cooling Water Diagram

"X" type

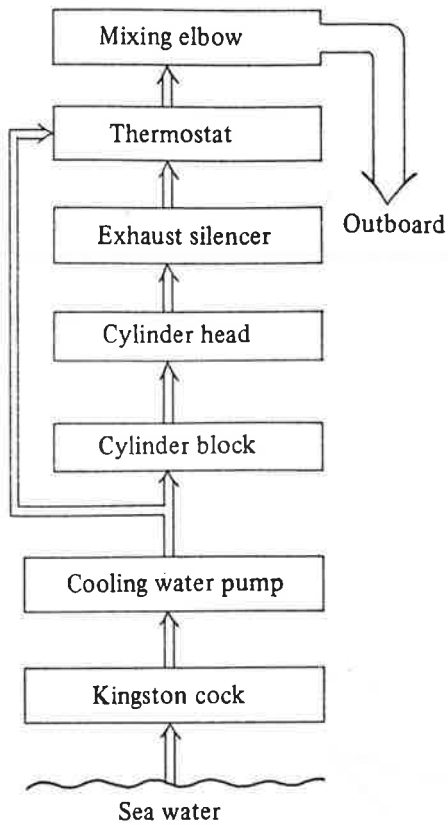

"Y" type

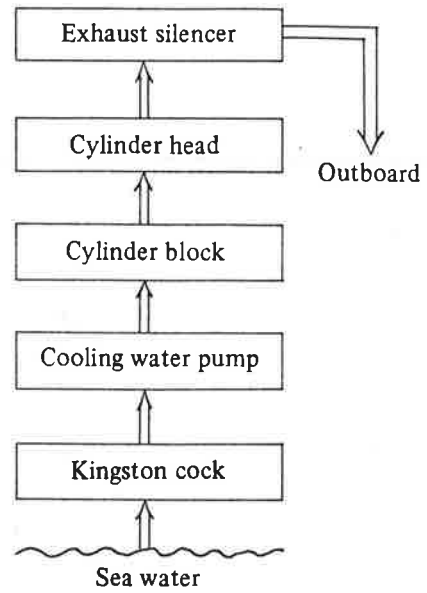

1-3-2. Lube Oil Diagram

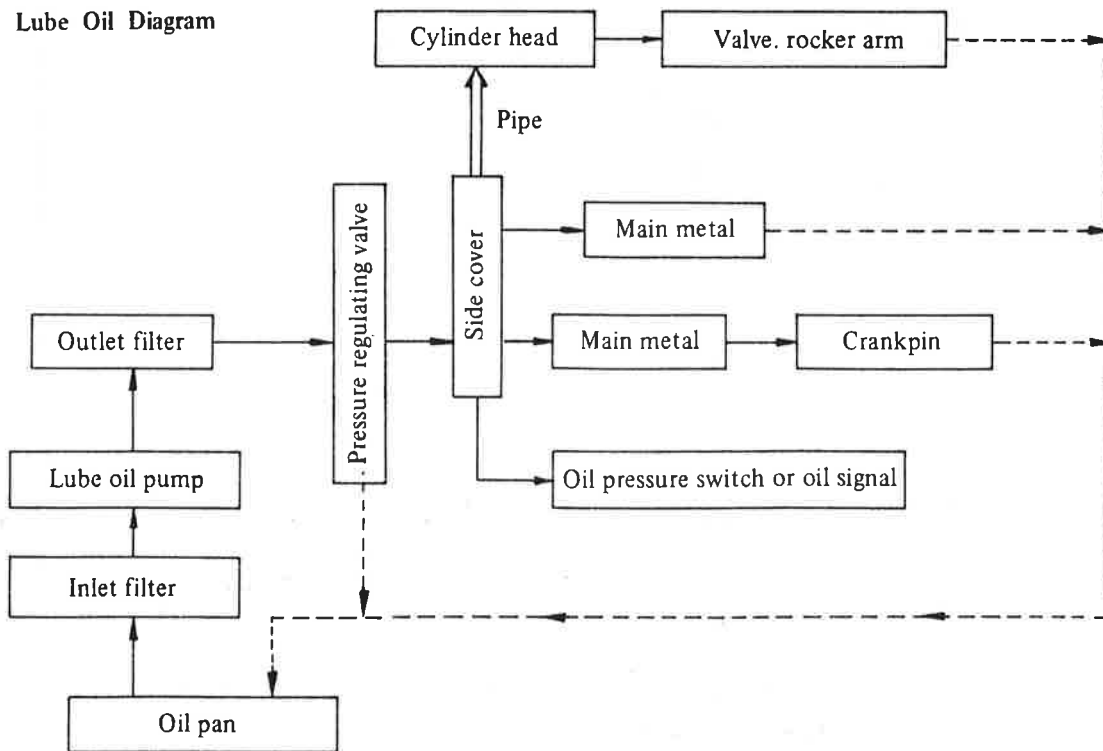

1-3-3. Fuel Diagram

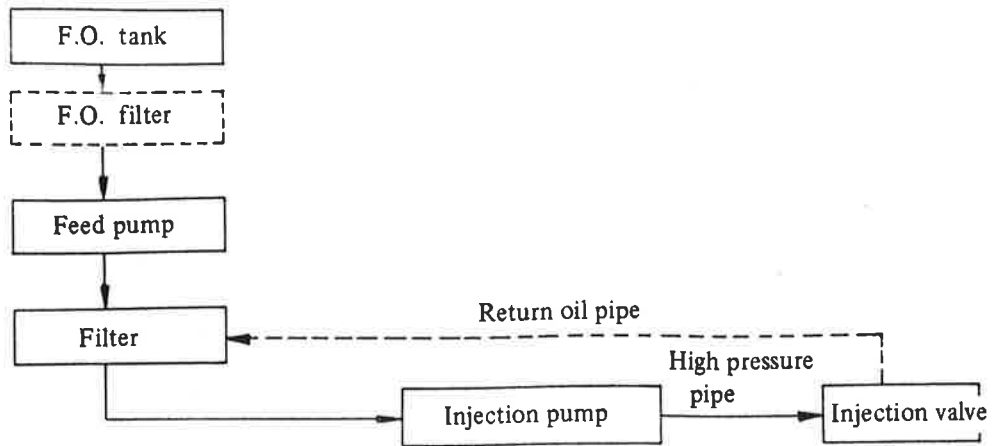

1-3-4. Electrical Wiring Diagram

NEW TYPE

SVE8/12 WIRING DIAGRAM

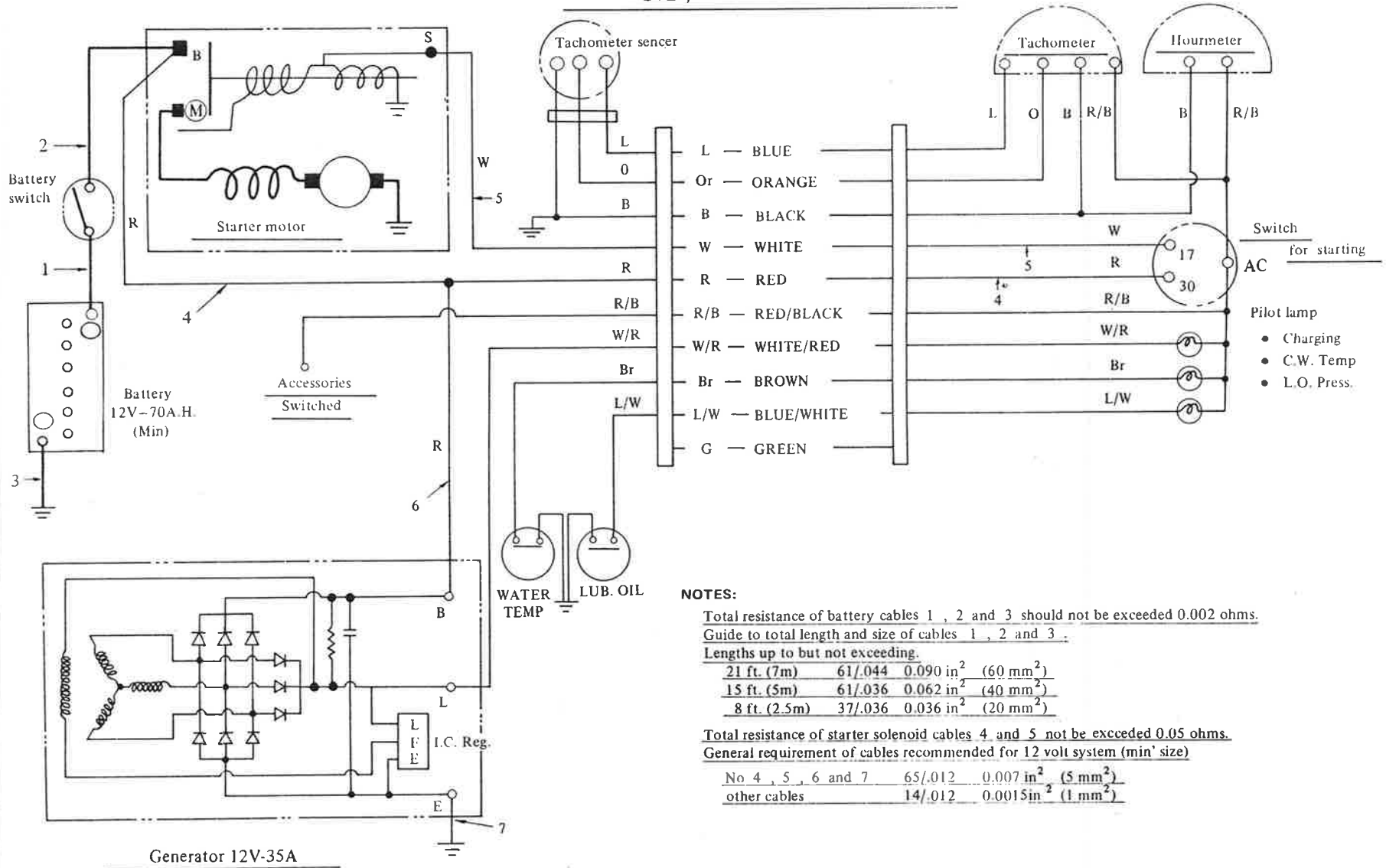

NOTES:

Total resistance of battery cables 1, 2 and 3 should not be exceeded 0.002 ohms.

Guide to total length and size of cables 1, 2 and 3.

Lengths up to but not exceeding.

21 ft. (7m)	61/.044	0.090 in <sup>2</sup>	(60 mm <sup>2</sup> )
15 ft. (5m)	61/.036	0.062 in <sup>2</sup>	(40 mm <sup>2</sup> )
8 ft. (2.5m)	37/.036	0.036 in <sup>2</sup>	(20 mm <sup>2</sup> )

Total resistance of starter solenoid cables 4 and 5 not be exceeded 0.05 ohms.

General requirement of cables recommended for 12 volt system (min' size)

No 4, 5, 6 and 7	65/.012	0.007 in <sup>2</sup>	(5 mm <sup>2</sup> )
other cables	14/.012	0.0015 in <sup>2</sup>	(1 mm <sup>2</sup> )

1-3-5. GEAR TRAIN

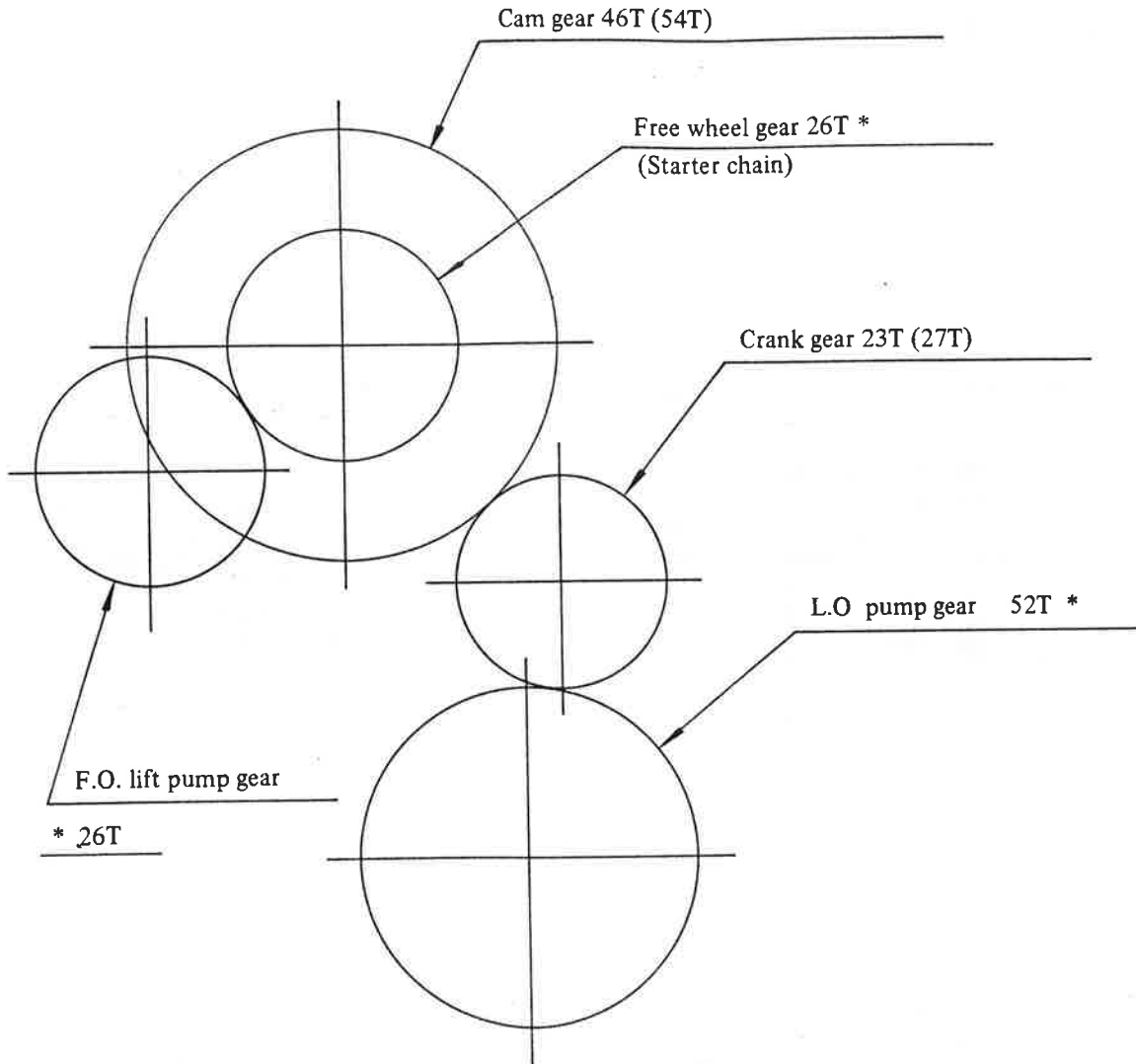

Figures without parentheses = Model SVE8  
Figures in parentheses = Model SVE12  
Mark with \* = COMMON in each Model (SVE8 SVE12)

1-3-6. MARINE GEAR

1) AHEAD

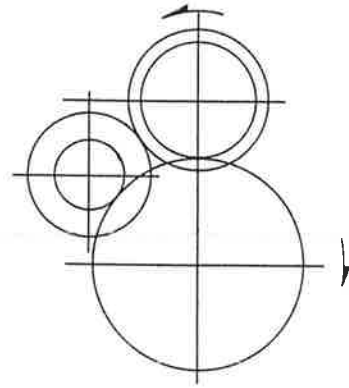
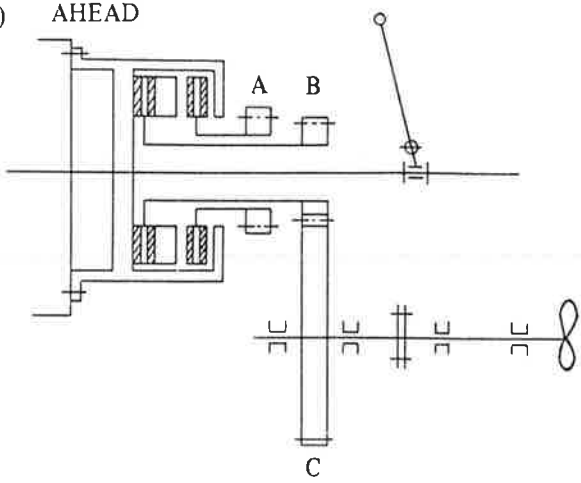

2) NEUTRAL

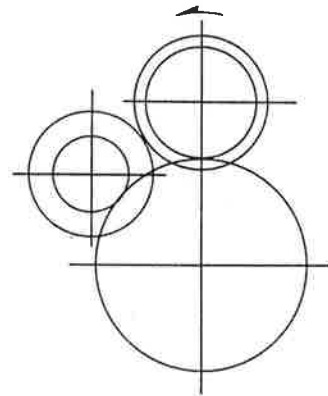
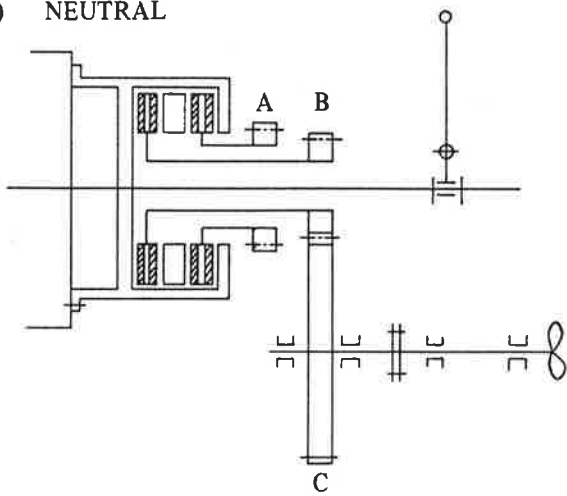

3) ASTERN

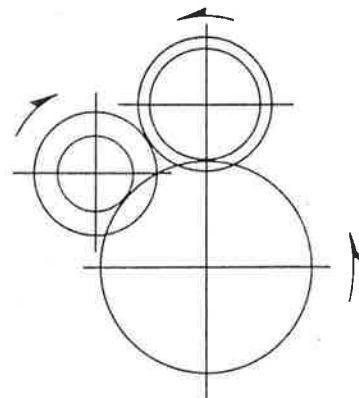
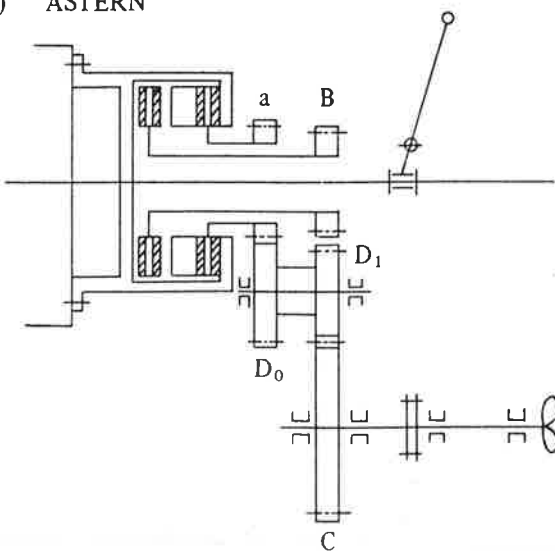

## Description of mechanism

The four gears in the reduction reversing gear (one of which is a monoblock large and small gear) are usually meshed with each other and turning whenever the engine is operating.

(1) When moving ahead:

There are two friction discs. The power is transmitted to the left friction disc, then from gear A to gear C to drive the propeller shaft.

(2) When moving astern:

The power is transmitted to the right friction disc, and in turn to gear A, gear D (gears  $D_0$  &  $D_1$ ) and gear C, and drives the propeller shaft.

Thus, by operating, a gear lever, the right and left friction discs are used as appropriate, depending upon the transmission mode of ahead or astern. All gears are constant meshed type, and the friction discs are normally turning in opposite directions except in their neutral position.

(3) When in neutral position:

The two friction discs are free from the friction plate, and gears A, B, C and D are all stationary even when the engine is running. A neutral positioning piece is furnished so as not to transmit power to between the friction plate and the friction discs. Therefore, "accompaniment" does not occur with the propeller shaft while the mechanism is in its neutral position.

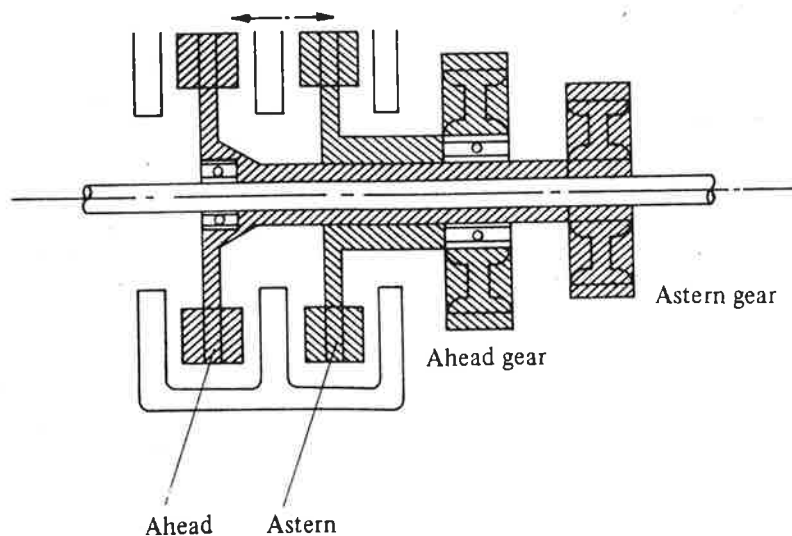

# 1-4. PIPING DIAGRAM

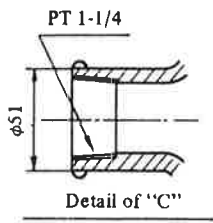
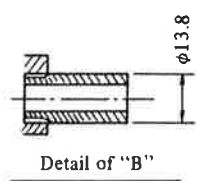
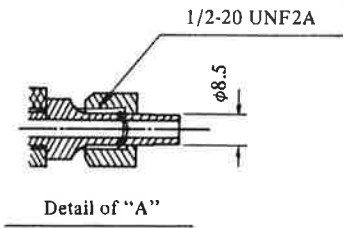
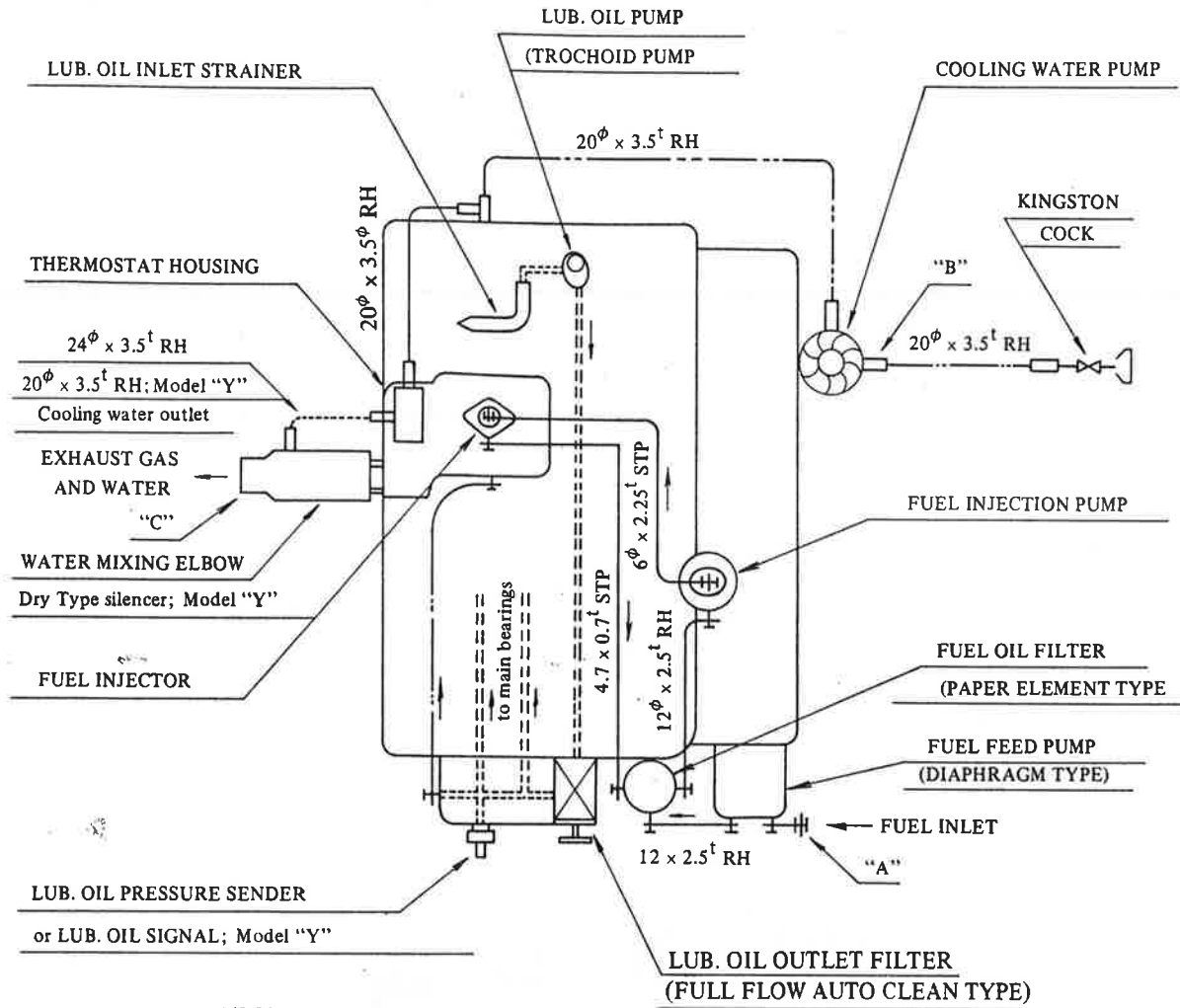

Marks of Piping	
	Fuel oil piping
	Lub. oil piping
	Cooling water piping
	Drilling hole
	Ball type joint
	Screw type joint
	Rubber hose Insertion type joint
STP	Steel pipe
RH	Rubber hose

## 1-6. Use of Front PTO Device

Due to the installation and structure of the engine, caution should be exercised regarding the following points when using the front PTO device.

- 1) If the engine is installed without flexible engine mounts, V-belts can be applied.
- 2) If the engine is mounted on flexible engine mounts, be sure to use a flexible coupling or a universal joint.
- 3) Refer to the graph for pullout output.

(1) Example of direct coupling to a working machine:

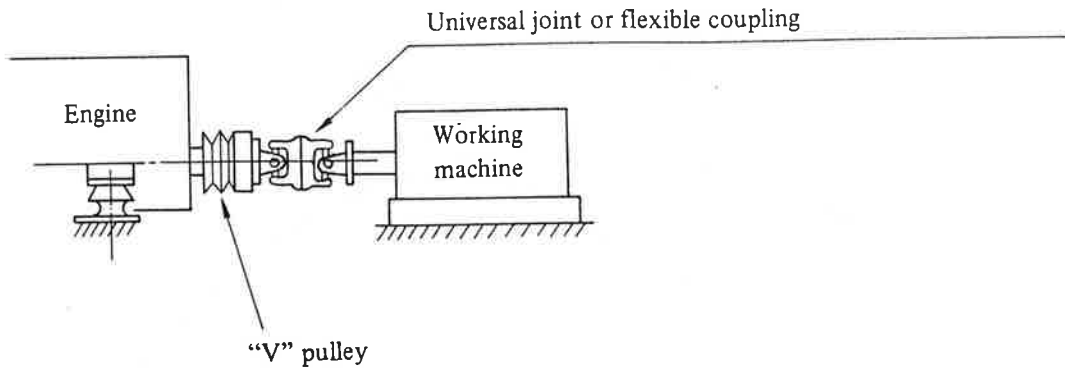

(2) Example of belt drive:

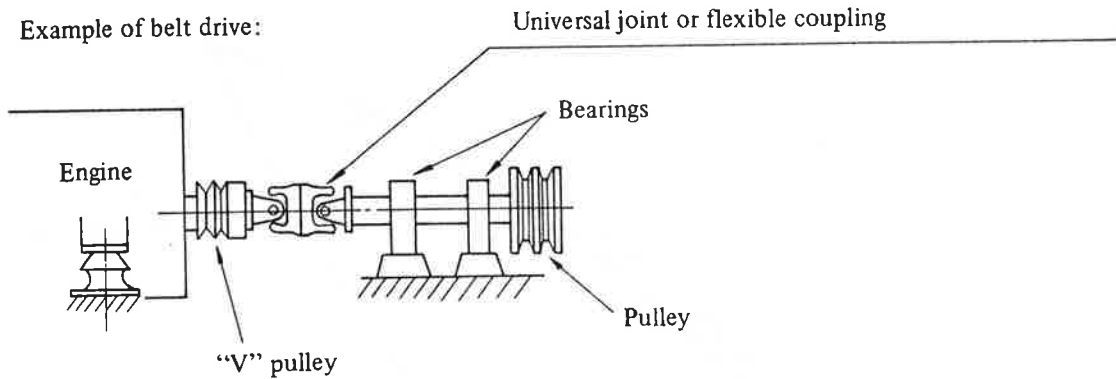

\* V-pulley details

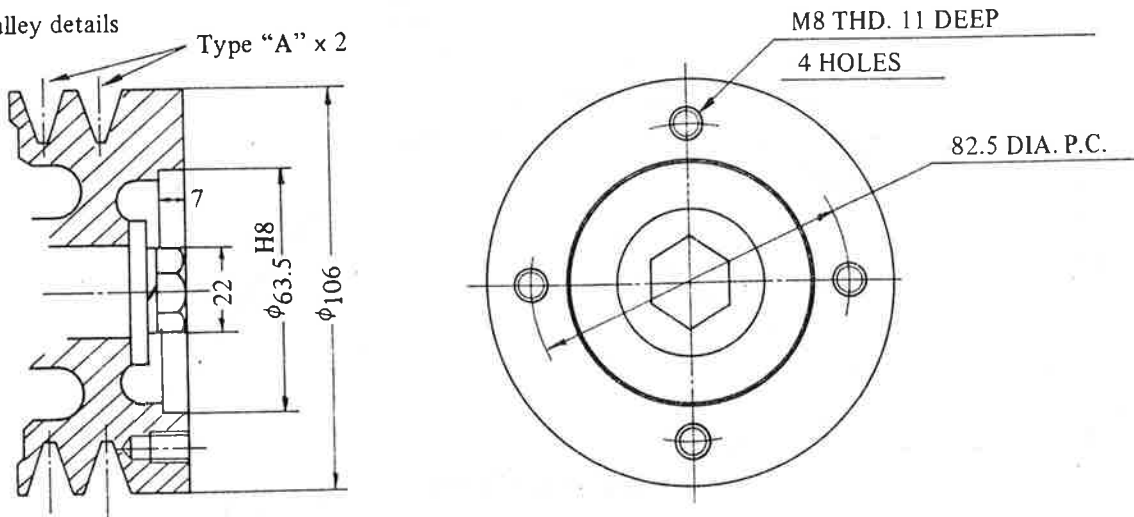

Front P.T.O.

Output Power

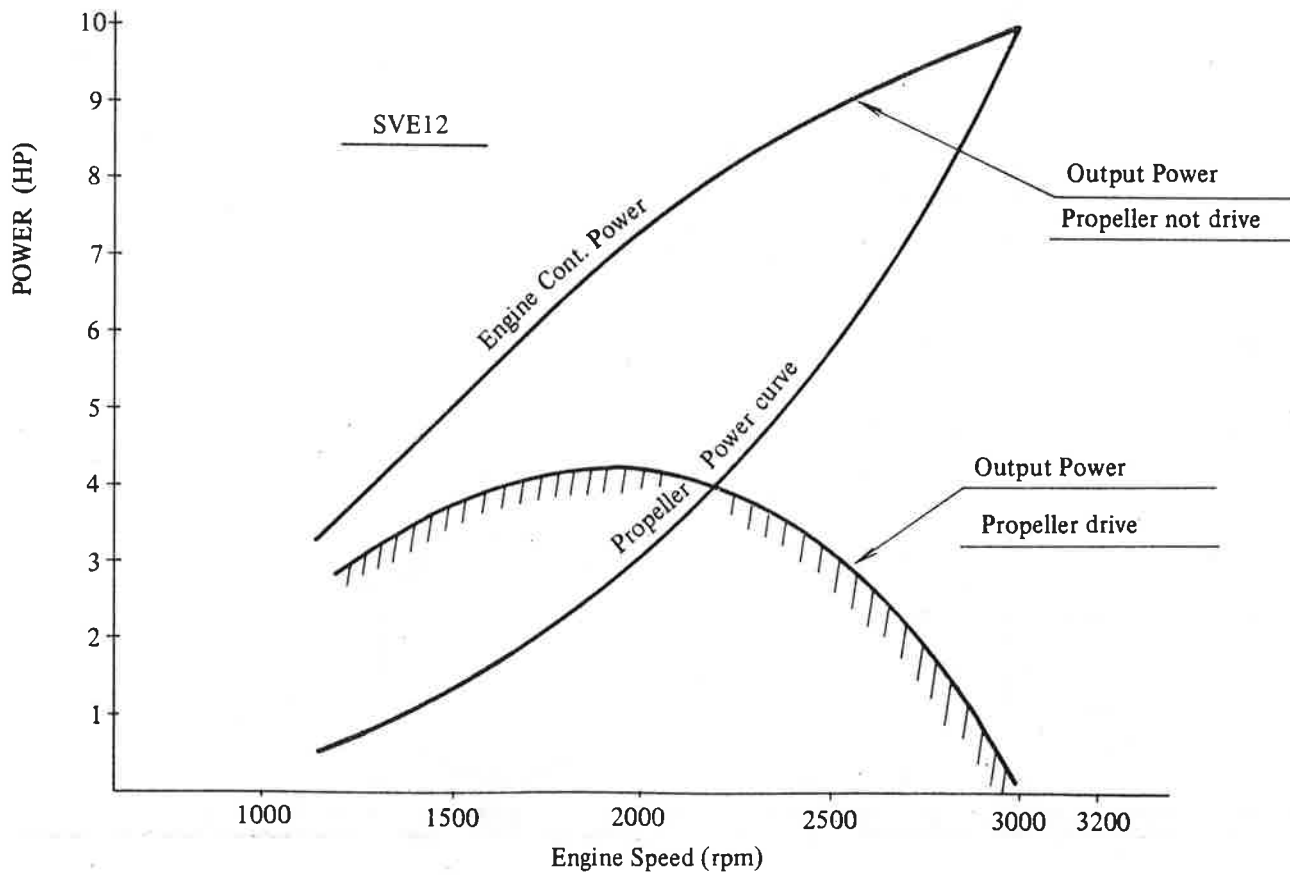
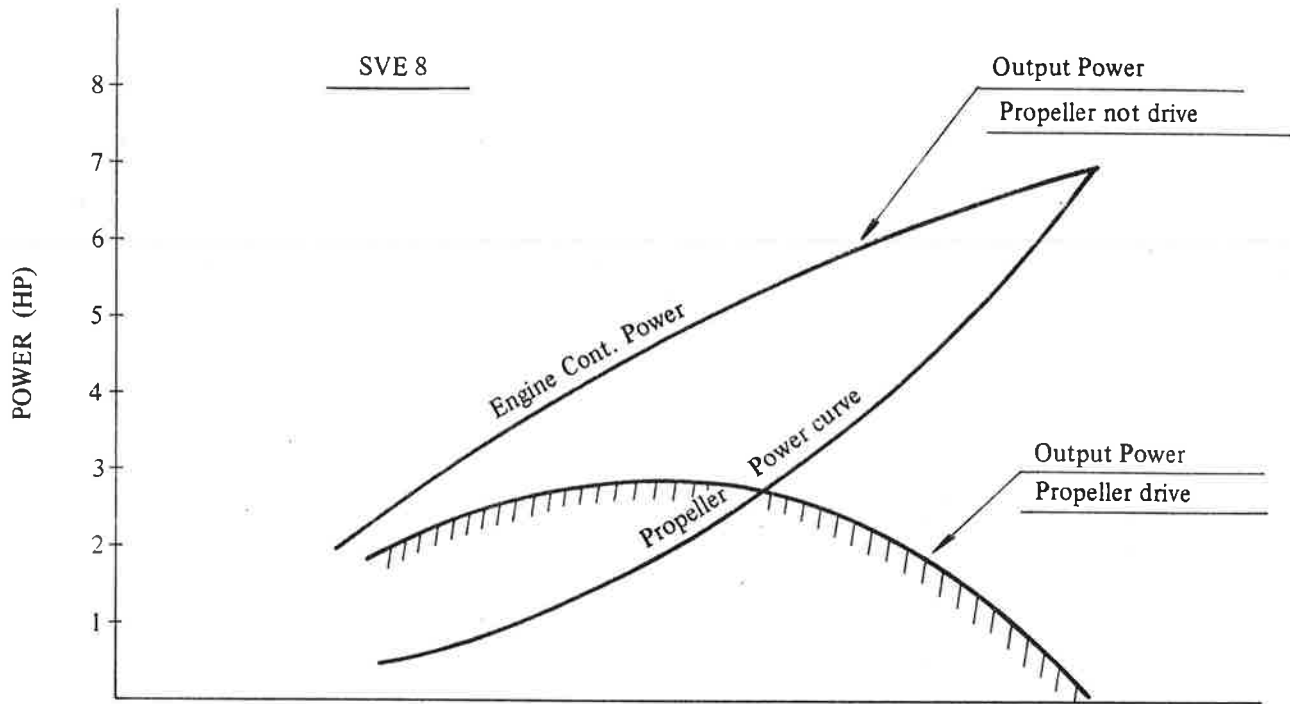

1--7. Remote Control

DE COMPRESSION CONTROL	YANMAR ORIGINAL CABLES (3 m) No. 104214-03700	
ENGINE SPEED CONTROL	MORSE	
	CABLE	33-C
	CABLE CLAMP and SHIM	A31804
	CLEVIS	A31800
CLUTCH CONTROL	MORSE	
	CABLE	64-BC
CONTROLS	MORSE	Two Lever Type
	MS	
	MJ	
	MJB	

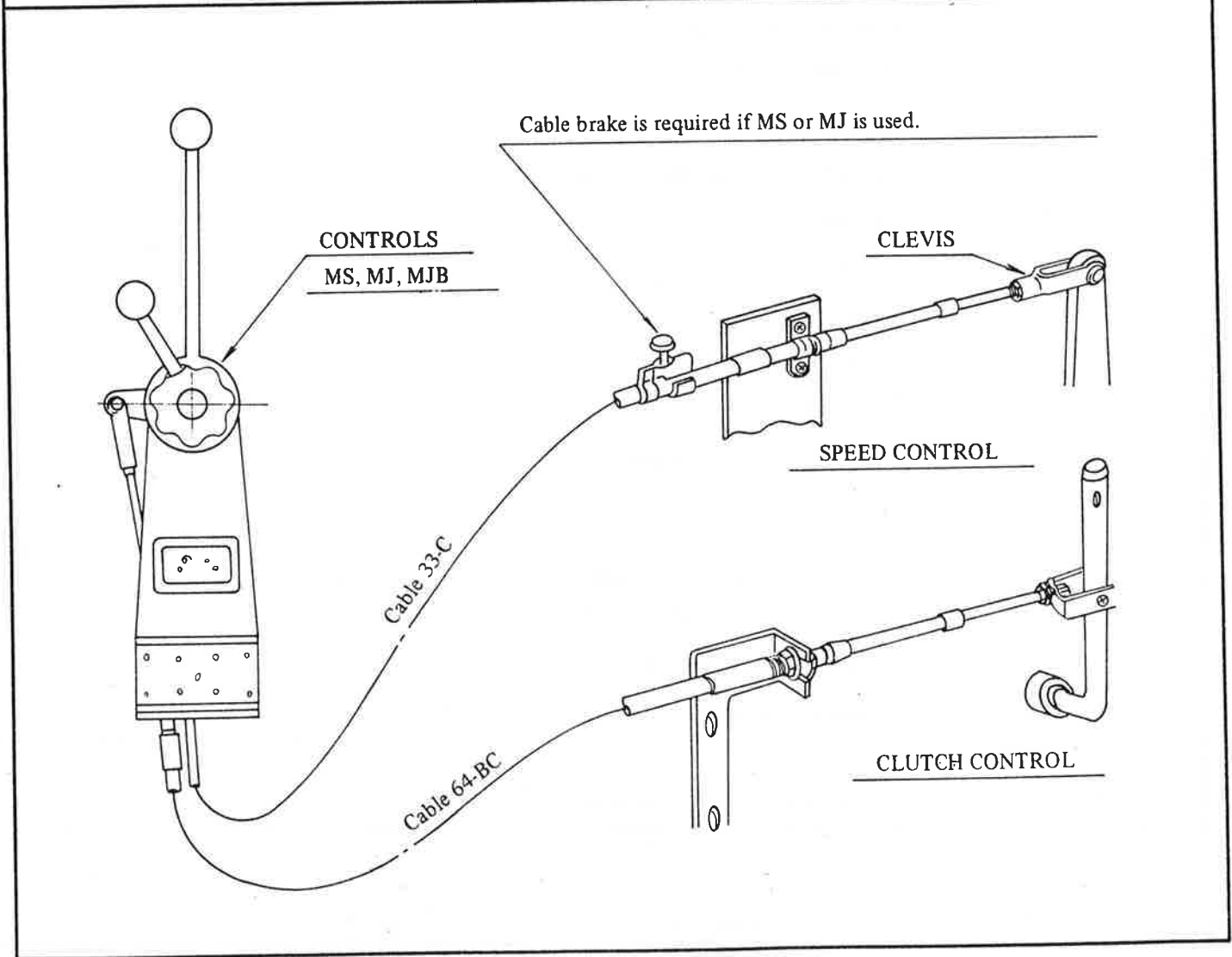

1-8. Accessories

○ : Standard

△ : Optional Extra

No.	System	Description	Type "X"	Type "Y"	Remarks
	Fuel system	F.O. tank assembly (20 ℓ) with piping	—	○	
		F.O. strainer	○	○	
		F.O. feed pump (mechanical)	○	—	
	Lubricating system	L.O. evacuation pump	△	△	
		Oil pressure switch	○	—	
	Cooling system	C.W. pump	○	○	
		C.W. temperature switch	○	—	
		Thermostat	○	—	
		Kingston cock and pipe	△	○	
		Bilge pump and strainer	△	—	
	Intake and exhaust system	Exhaust silencer assembly (small size)	○	—	
		Exhaust silencer assembly (large size)	—	○	
		Exhaust pipe	—	○	
		Elbow	○	○	
		U-type mixing elbow	○	—	
		Straight type mixing elbow	△	—	
		Intake pipe	○	○	
	Starting system	Manual starting system (camshaft starting)	○	—	
		Manual starting system (chain starting)	—	○	
		Electric starting device (Starting motor 12V - 1KW) (Alternator 12V - 35A)	○	—	
	Gauge board	Gauge board (with 3 m wire)	○	—	
		Extension cord (3 m)	△	—	
		Battery switch	△	—	
		Tachometer and tachometer sensor	△	—	

No.	System	Description	Type "X"	Type "Y"	Remarks
	Control system	Speed control bracket	○	○	
		Clutch control bracket	○	—	
		Decompression bracket	○	—	
		Decompression control cable	△	—	
		Speed control cable	—	○	With accelerator-lever
	Installation	Flexible mounting	△	—	
		Flexible coupling	△	—	
		Taper type solid coupling	△	○	
		Slit type coupling	△	—	
		Foundation bolt assembly	—	○	
		Foundation plate	△	—	
	Others	Standard tools for overhauling	○	○	
		Special tools for overhauling	△	△	
		Operation manual	○	○	
		Propeller	—	△	
		Keel type stern arrangement	△	△	
		* Spare parts kit	△	△	
		Packing kit	△	△	

\* Spare parts kit (for one unit)

	Description	Quantity
1	Piston ring set	1 set
2	Gasket packing (cylinder head)	1
3	Gasket packing (exhaust silencer)	1
4	F.O. strainer element	1
*5	Oil pressure switch	1
*6	Water temperature switch	1
*7	Thermostat	1
8	F.O. injection nozzle	1 set
9	Anticorrosive zinc	1
*10	Lamp 12V - 3.4 W	3
11	C.W. pump impeller	1
12	V-belt (alternator)	1

"Y" type does not include \* parts

2. MAINTENANCE AND INSPECTION

2-1. FUEL OIL & LUBRICANT

1. Fuel oil

Use diesel light oil or diesel oil.

Recommended brand names of fuel

Supplier	Brand Name
SHELL	Shell diesoline or local equivalent
CALTEX	Caltex diesel oil
MOBIL	Mobil diesel oil
ESSO	Esso diesel oil
B.P. (British Petroleum)	B.P. diesel oil

2. Lubricating oil

Recommended brand names of lube oil for crankcase & gear box

Supplier	Brand Name	SAE No.			
		below 10°C	10 ~ 20°C	20 ~ 35°C	over 35°C
SHELL	Shell Rotella oil	10W 20/20W	20/20W	30 40	50
	Shell Talona oil	10W	20	30 40	50
	Shell Rimula oil	20/20W	20/20W	30 40	—
CALTEX	RPM Delo Marine oil	10W	20	30 40	50
	RPM Delo Multi Service oil	20/20W 10W	20	30	50
MOBIL	Delvac Special	10W	20	30	—
	Delvac 20W-40	20W-40	20W-40	—	—
	Delvac 1100 Series	10W 20-20W	20-20W	30 40	50
	Delvac 1200 Series	10W 20-20W	20-20W	30 40	50
ESSO	Estor HD	10W	20	30 40	—
	Esso Lube HD	—	20	30 40	50
	Standard Diesel oil	10W	20	30 40	50
B.P. (British Petroleum)	BP Energol ICM BP Vanellus BP Diesel S3 BP Vanellus S3	20W	20W	40	50

Remarks: The viscosity grade of the lube oil should suit the ambient air temperature.

## A.P.I. Classification of Lubricating Oil

New A.P.I. service grade	Old A.P.I. service grade	Engine type for which suited
CA	GD	Low mean pressure
CB, CC	DM	Middle mean pressure
CD	DS	High mean pressure

**CA:** Suited for diesel engines using high quality fuel and running light loads; applicable to gasoline engines running light loads. Prevents bearing corrosion and high temperature deposits.

**CB:** Suited for diesel engines running with medium loads and using low quality fuel oil which may cause corrosion and deposit troubles. Prevents bearing corrosion and high temperature deposits in diesel engines using fuel oil of high sulphur content.

**CC:** Suitable for lightly supercharged diesel engines run under medium and high load conditions and for certain types of heavily loaded gasoline engines. Applicable to a variety of civil construction machines, agricultural machines and marine machines. Prevents high and low temperature deposits and corrosion.

**CD:** Suitable for high speed, high output supercharged diesel engines. Prevents bearing corrosion and high temperature deposits in supercharged diesel engines which use low quality fuel oil.

**Note:** Use Lube oil of CB, CC, or CD class for the SVE 8,12 engine.

### 3. Crank-case

Remove the oil cap and fill with lube oil to the upper mark on the dipstick.

When checking the oil level, insert the dipstick completely.

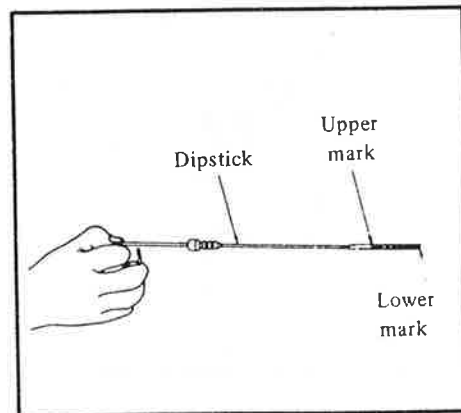
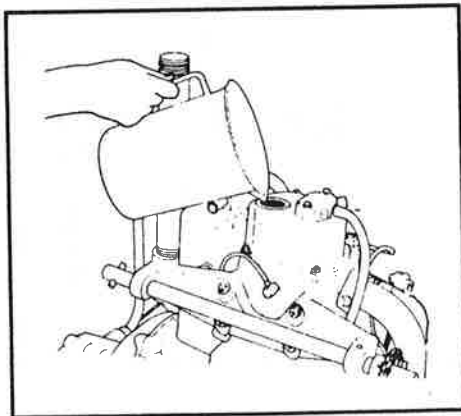

The volume of lube oil is as follows.

Model	Volume
SVE8	2.8 L.
SVE12	3.5 L.

#### 4. Clutch-case

Remove the oil cap and fill with lube oil to the upper mark on the dipstick.

When checking the oil level, do not screw the lube oil dipstick on.

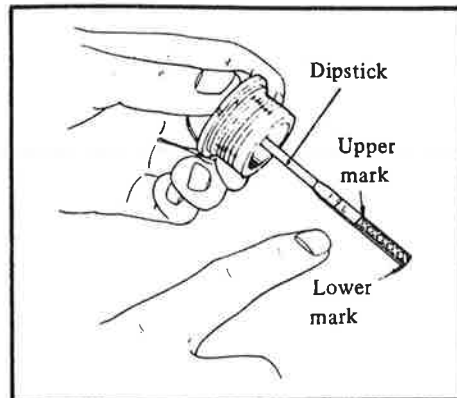
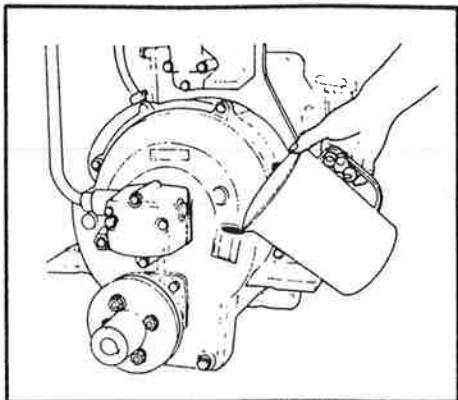

The volume of lube oil is as follows.

Model	Volume
SVE8	0.5 L.
SVE12	

#### 5. Lubrication of each part

Lubricate the starting chain and the starting shaft bearing with lube oil before operation.

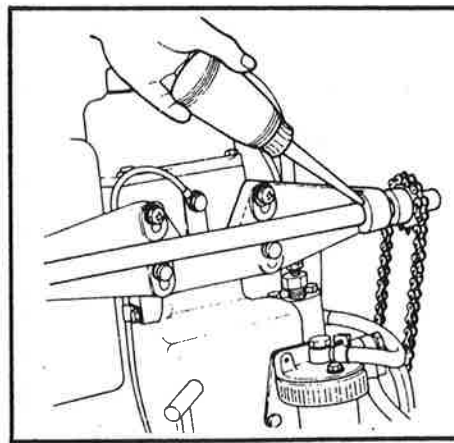
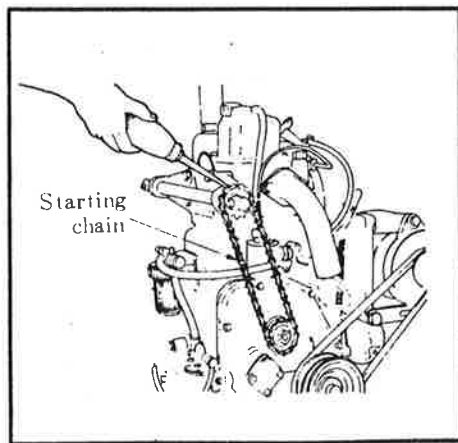

### 2-2 Pointers for Maintenance

#### 1. Preparation before starting

In order to keep the engine in top running condition, conduct regular maintenance checks.

In this way small malfunctions can be detected early and corrected before causing major problems.

- 1) Check the lube oil level periodically. (Both crankcase and clutch case)

- 2) Check the fuel oil level and refill periodically.
- 3) Fuel will not inject if any air is in the system. Unless the fuel tank runs dry or the parts are dismantled, it should not be necessary to repeat the air venting procedure.

### AIR VENTING

Before starting, air should be vented from the fuel line according to following sequence.

- 1) Loosen the fuel strainer plug. When bubble-free fuel appears, securely retighten the plug.

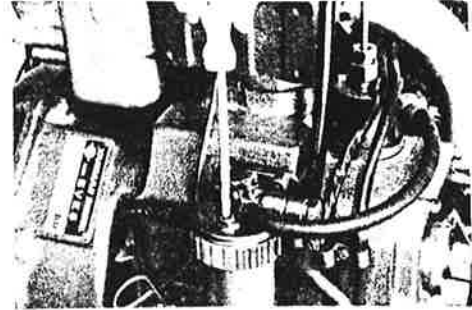

- 2) Loosen the nipples at each end of the fuel injection pipe. Set the speed control lever to HIGH.

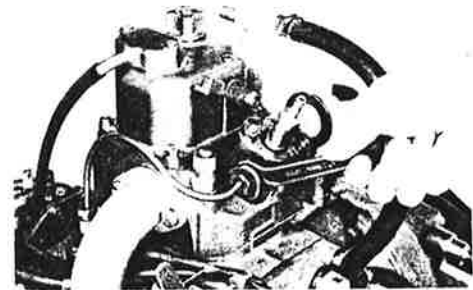

- 3) Loosen the delivery valve holder (by about 2 turns), and when bubble-free fuel comes out, securely tighten the delivery valve holder. After attaching the injection pipe, securely tighten the fuel pump side nipple.



- 4) Now turn the engine with the the starting handle about 30 times. Fuel oil is circulated and appears from the nipple on the injection valve side. When no more air bubbles are present in the oil, tighten the nipple.
- 5) Continue turning the engine until you hear the sound of fuel being injected, indicating that the air has been completely vented.

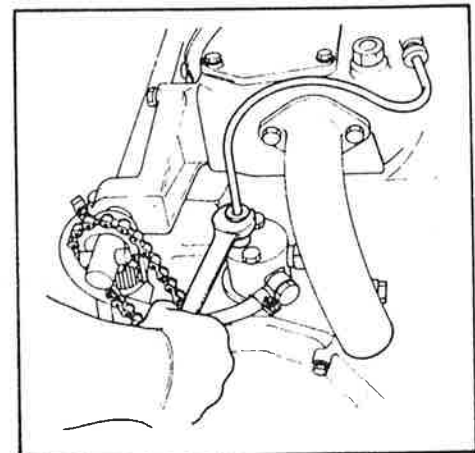

### ATTENTION

Start the engine every 10 days in order to check the engine condition, or turn the starting handle by hand to lubricate each part. Further turn the starting handle until you hear the sound of fuel being injected.

## 2. Starting procedure

- 1) Open the fuel cock.
- 2) Open the kingston cock.
- 3) Set the speed control lever to HIGH and the clutch lever to NEUTRAL.

- 4) Raise the decompression lever and turn the starting handle vigorously 5 or 6 times until the flywheel gains momentum.

Handle of the lube oil filter

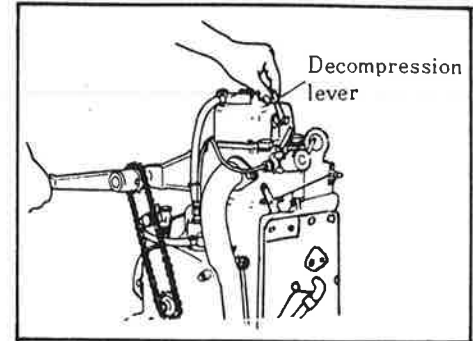

- 5) Release the decompression lever and further turn the starting handle 2 or 3 times more.
- 6) If the engine is operating normally, shift into low speed with the clutch and then gradually increase speed.

## 2-3. Normal Operation

### 1. Before operation

- 1) Check the fuel oil level in the tank and refill if necessary.
- 2) Open the fuel cock.
- 3) Check the lube oil level in the crank case and clutch case.  
Refill up to the upper mark on the dipstick.
- 4) Turn the handle of the lube oil filter on the outlet side several times to the left or right.
- 5) Open the kingston cock.
- 6) Turn the starting handle by hand in order to lubricate each part
- 7) Set the speed control lever to HIGH.
- 8) Turn the starting handle until you hear the sound of fuel being injected.

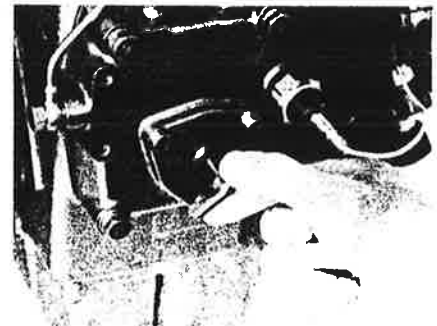

**Note:** Fuel is not injected if air is present anywhere in this system.  
Air enters the system when fuel runs out and when the fuel injection pump is stripped.

### 2. Starting

- 1) Set the speed control lever to HIGH.

- 2) Raise the decompression lever and turn the starting handle vigorously five or six times until the flywheel obtains momentum.
- 3) Release the decompression lever and further turn the starting handle firmly.
- 4) Warm up the engine at 600–700 rpm without a load for at least 5 minutes.

### 3. During operation

- 1) Check that cooling water is coming out of the cooling water pipe outlet.

### 4. Stopping

- 1) Set the speed control lever to STOP position.
- 2) Close the fuel cock.
- 3) Close the kingston cock.

**Note:** In cold weather, drain out the cooling water to prevent freezing.

- \* Close the kingston cock and drain out the water from the engine through the drain cock attached to the water jacket cover.
- \* Loosen and remove the cooling water pump intake & outlet pipes. Drain out the water from the pipes, and then turn the engine several times with the starting handle to discharge the water from the cooling water pump.

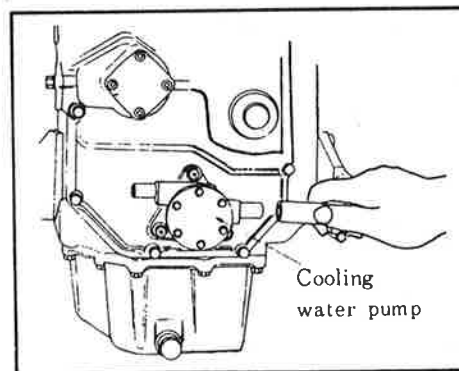
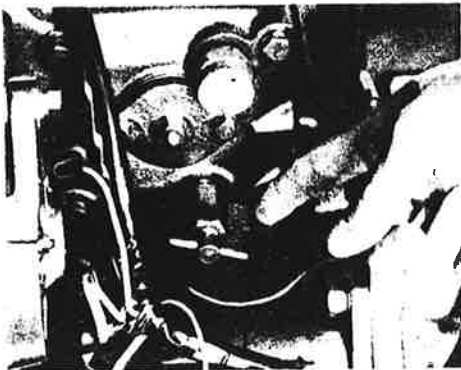

- 4) Stop the engine at the compression stroke by turning it with the starting handle until resistance is felt. Do not use the decompression lever. At this position the intake & exhaust valves are closed, protecting the cylinder and valve seats from moisture.

## 2-4. Periodic Check Table

A periodic check is necessary in order to keep the engine in good running condition at all times. The periodic check program varies depending upon frequency and usage of the engine, type of service fuel, quality of lube oil, handling of the engine, etc., therefore, making it difficult to specify exactly what is needed. Thus, only general explanations are given in the following.

For details see descriptions on each respective item.

Item Check		Daily	Every 100 hours	Every 250 hours	Every 500 hours	Every 1000 hours
Fuel oil	Check fuel oil level and replenish	○				
	Remove drain from fuel tank	○ (before replenishment)				
	Clean/replace fuel oil filter element		○ (clean)		○ (replace)	
Lube oil	Check oil level of crank case/reduction gear case	○				
	Oil each part (starting shaft chain, etc.)	○				
	Turn L.O. filter handle	○				
	Disassemble and clean L.O. filter		○			
	Replace L.O. in crankcase		○			
	Replace L.O. in clutchcase			○		
Cooling water	Discharge cooling water	○ (after operation in a cold state)				
	Confirm suction of cooling water	○				
	Check impeller and pump casing					○
	Replace impeller					○
	Clean thermostat			○		
Fuel injection pump	Fuel injection condition (confirm injection sound)	○				
	Adjust fuel injection regulator			○		
	Confirm fuel injection timing				○	
Fuel injection valve	Clean needle valve				○	
	Check injection condition			○		
	Check and measure injection pressure			○		
Cylinder head	Retighten head nuts		○			
	Adjust intake/exhaust valve clearance			○		
	Clean combustion surfaces					○
	Clean precombustion chamber					○
	Lap intake/exhaust valves					○
	Check rocker arms and valve guides					○
Clean breather valve			○			
Check belt tension (generator drive belt)			○			
Replace anticorrosive zinc					○	
Disassemble piston/check piston rings						○

## 2-5. PERIODIC CHECKS

The following are periodic check points for a general use engine, as opposed to the check points of a life boat engine which must be determined accordingly.

### I. Every 100 Hours

- 1) Remove the fuel oil strainer and wash it in light oil.
  - 2) Clean the inside of the lube oil strainer. Remove the three strainer cover set bolts and pull out the strainer. Wash thoroughly with light oil. Brush off dirt adhering to the strainer plates.
  - 3) Drain out the lube oil from the crankcase and wash the interior with light oil. Then refill with lube oil.
  - 4) Retightening of the cylinder head nuts.
- | Model | Tightening Torque: kg-m(ft-lb) |
|-------|--------------------------------|
| SVE8  | 8.8 (63.7)                     |
| SVE12 | 12.4 (79.7)                    |
- 5) Remove the air breather case and wash the air breather valve in light oil.

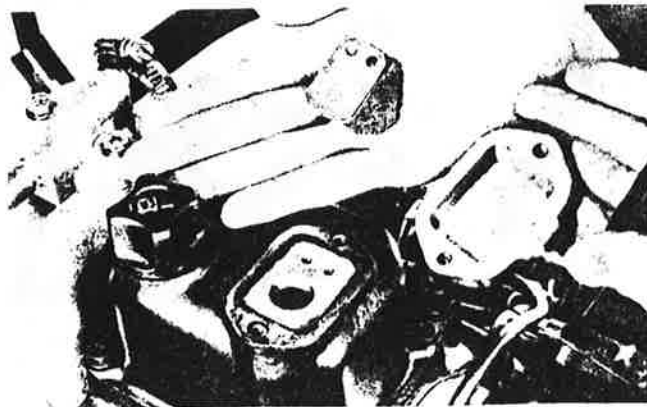
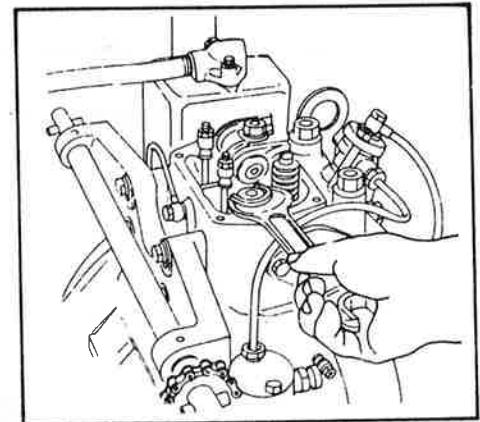
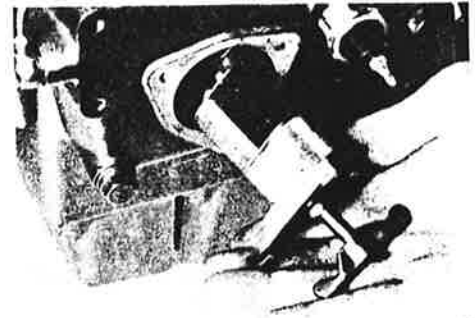
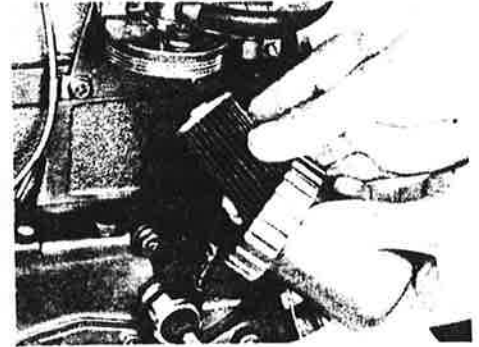

- 
- 6) Belt play should be about 5 mm.

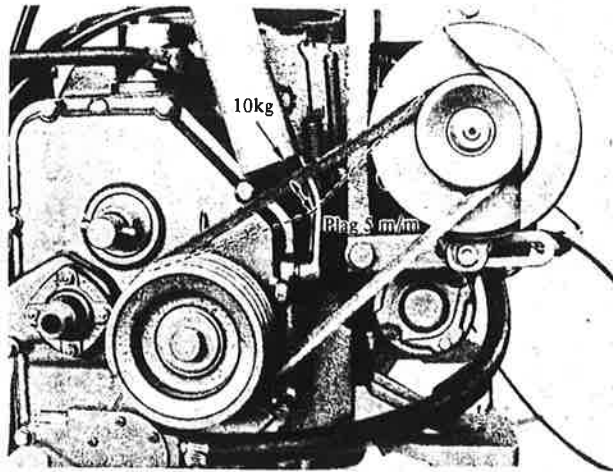

**2. Every 250 Hours**

- 1) Drain the lube oil from the clutch case and wash the interior with light oil. Refill with fresh lube oil.
- 2) Adjustment of the fuel injection regulator
- 3) Adjustment of the fuel injection valve
- 4) Check the valve clearance of both intake and exhaust valves.
- 5) Cleaning of the thermostat device

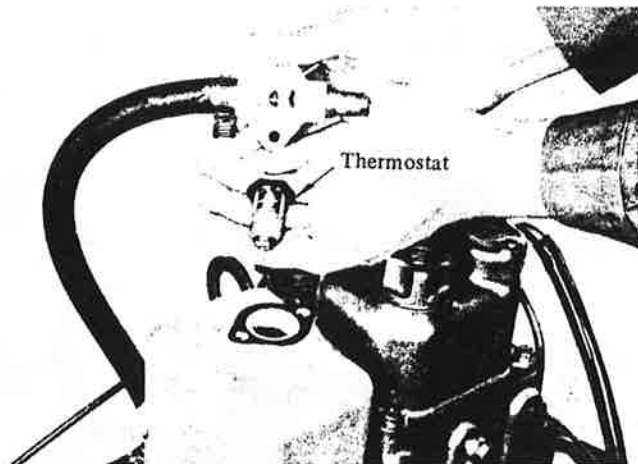

3. Every 500 Hours

- 1) Replace the fuel strainer element.
- 2) Check the fuel injection timing.
- 3) Disassemble the fuel injection valve and clean the needle valve. Recheck fuel injection condition after reassembly.
- 4) Change the anti-corrosive zinc.

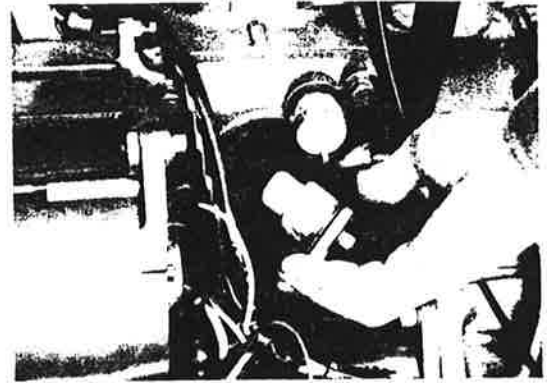

4. Every 1000 Hours

- 1) Check the cooling water pump casing and replace the impeller.

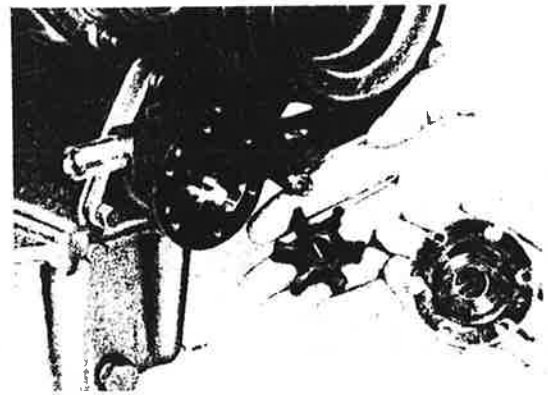

- 2) Strip and clean the cylinder head and lap the valve seats.

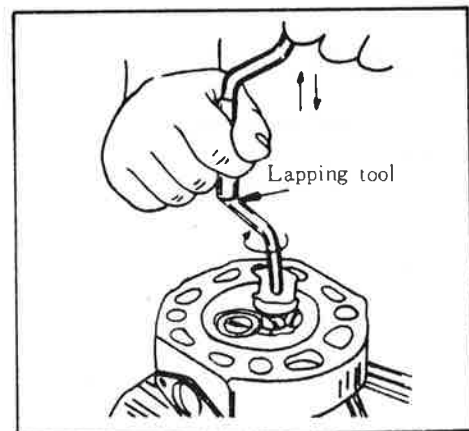



- 3) Clean the piston and rings.
- 4) Check rocker arms and valve guides.

### 3. ALIGNMENT OF ENGINE

#### 3-1. Tools for Overhaul and Reassembling General tools

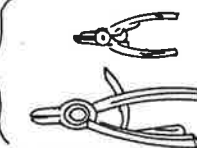
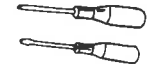
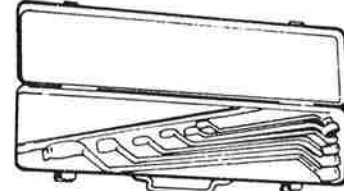
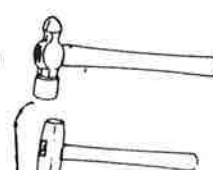
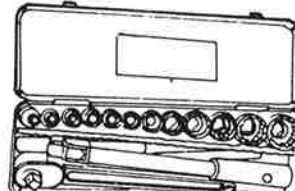
##### General tools:

1	Spanner	10 x 13	YANMAR standard	①		
2	"	17 x 19		②		
3	"	22 x 24		③		
4	Screwdriver		Local supply	④		
5	Pliers			⑤		
6	Nipper (Diagonal plier)			⑥		
7	Steel hammer			⑦		
8	Wooden or copper hammer			⑧		
9	Monkey wrench (Adjustable wrench)			⑧		
10	Snap ring plier					
11	Offset wrench					⑨
12	Socket wrench					⑩
13	Files				⑪	
14	Sand paper				⑫	

##### Special tools

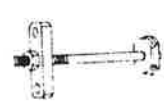
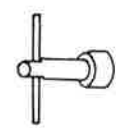
1	Liner extraction implement		YANMAR special order	①		
2	Flywheel extraction set (Flywheel end nut spanner & replacer)			②		
3	Main bearing replacer			③		
4	V-pulley removal tool			④		
5	Piston ring compressor			⑤		

6	Nozzle body pullout implement	YANMAR Special order		
7	Valve seat lapping tool			
8	Piston pin remover	Local supply		
9	Valve seat cutter			
10	Gear puller			
11	Ball bearing puller			

### Measuring and inspection tools

#### Measuring

1	Vernier calipers		
2	Micrometer		
3	Cylinder gauge		
4	Dial gauge		
5	Feeler gauge		
6	Ruler		
7	Square		
8	Torque wrench		
9	Tachometer		
<b>Inspection</b>			
10	Nozzle tester		
11	Injected volume tester		
12	Electrical circuitry tester		
13	Hydraulic pressure tester		
14	Compressionä pressure tester		
15	Crack detection solution		

Other

Packing sheet		
Adhesives (water-proof, anti-solvent)		
Paints for repair		
Waste cloth		
Cleaner		
Pallet		

3--2. Engine Adjustment Specifications

Item	Unit	SVE8	SVE12	Remarks	
Top clearance	mm	0.78	1.25		
Decomp. lift	mm	1.0	1.0		
Intake/exhaust valve clearances	mm	0.2	0.2	In cold state	
Valve Timing	Intake valve opens	b.TDC	22°	19°	
	Intake valve closes	a.BDC	42°	39°	
	Exhaust valve opens	b.BDC	52°	49°	
	Exhaust valve closes	a.TDC	22°	19°	
Lube oil pressure	Kg/cm <sup>2</sup>	3±1	3±1	At rated speed	
Fuel oil injection pressure	Kg/cm <sup>2</sup>	160	160		
Fuel oil injection timing	b.TDC	12°	12°		
Crankshaft side gap	mm	0.24±0.1	0.2±0.1		
Installation	Center misalignment between clutch shaft and propeller shaft	mm	0.15 or less		
	Angular misalignment between clutch shaft and propeller shaft	mm	0.06 or less		
	Maximum angle of rake	degree	15°		

### 3-3. Measurements of Major Components

Before beginning the measuring operation, all parts to be measured must be cleaned and the measuring instruments must be well calibrated. After the completion of each measurement, all parts not falling within the allowance of the maintenance standard must be repaired or replaced with new ones. Upon completion of repair or replacement, check that the respective dimensions of the parts are within the values specified.

#### 3-3-1. Cylinder Liner

Procedure for replacement of cylinder liner:

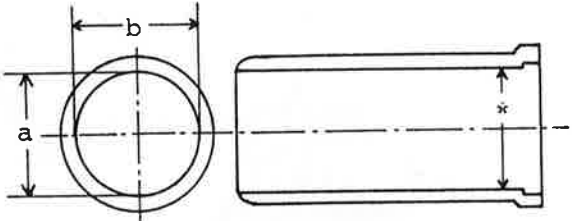
Measuring position	Remarks Dimension: m/m	Measuring Instrument
	<p>Measure in (a) (b) directions at position marked *</p> <p>(* mark is positioned in No. 1 piston ring at upper dead center.)</p> <ul style="list-style-type: none"> <li>○ Nominal size     SVE8   SVE12                              75mm   85mm</li> <li>○ Limit of use     +0.30   +0.34</li> </ul> <p style="text-align: center;">Reference</p> <ul style="list-style-type: none"> <li>○ Clearance between piston and cylinder liner</li> </ul> <p style="text-align: center;">Standard clearance of ass'y</p> <p style="text-align: right;">SVE8   SVE12 0.11   0.21</p> <p style="text-align: right;">Limit of use   0.38   0.43</p>	Cylinder gauge
<p>Simple method for measuring inner diameter of cylinder liner or thickness of piston ring.</p>		

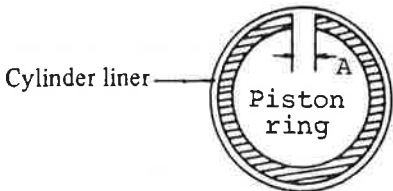
Measuring position	Remarks	Measuring Instrument
<p>Use a new cylinder or piston ring, whichever is tighter.</p> 	<p>Measure piston ring fitting dimension.</p> <p>Calculation of wear in inner dia. direction</p> $\frac{A - 0.3}{3.14} = \text{wear}$ <p>Here, if the cylinder liner is new, it is the doubled amount of wear in the thickness of ring. If a new ring is used, it is the amount of wear in inner dia. of cylinder liner.</p>	<p>Thickness gauge</p>

**Procedure for repacement of cylinder liner:**

1. Put the tightening nut on the two cylinder held mounting bolts opposite each other on a diagonal line, and pull out the liner with the liner pullout implement.
2. Remove the rubber packing from the liner.
3. Clean off foreign material such as paint, dirt and dust adhering to the gutter for rubber packing and the portion to which the liner is installed.

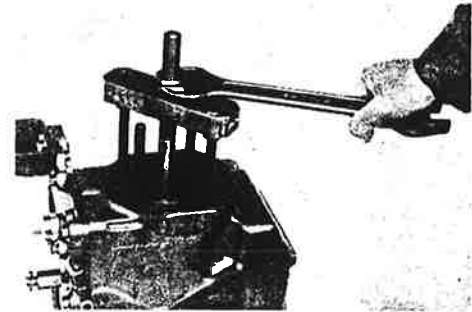

**Assembly**

1. Insert the liner rubber packing, taking care not to twist it.

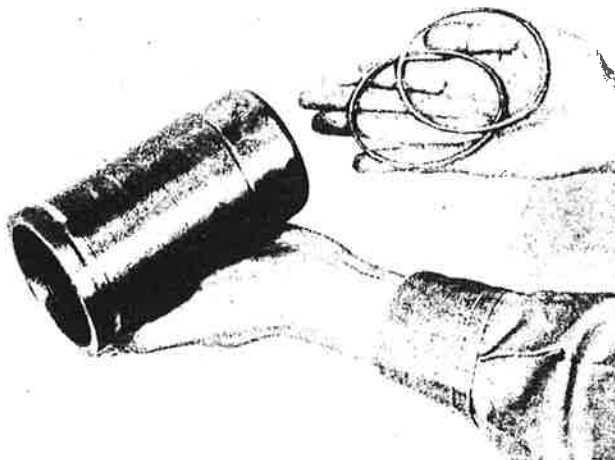

2. Apply white paint (seak paint) on the portions (front and rear) in which the liner is installed.
3. Insert the cylinder liner and tap in lightly on the head.
4. Put the two cylinder head tightening nuts on a diagonal line, and secure them.
5. Remove the head again, and measure the dimension at A (See Figure) with feeler gauge. (0.07 ~ 0.16 mm)

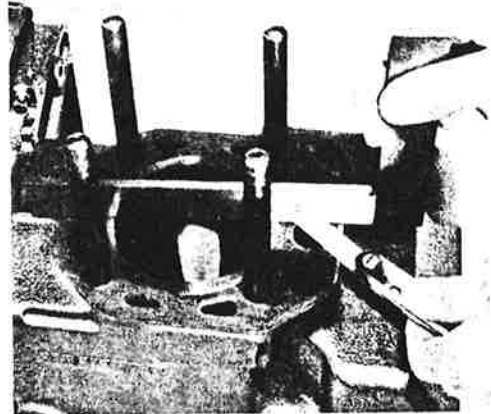
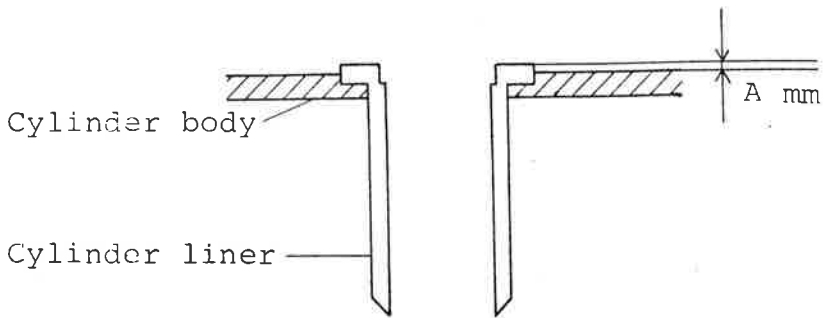

6. Measuring the inner diameter of the liner with a cylinder gauge, make sure there is no abnormality.

3-3-2. Thrust Metal

Measuring position	Remarks	Measuring Instrument
<p>Thickness</p>	<p>Nominal size 2.5mm</p> <p>Limit of use -0.3</p>	<p>Micrometer</p>

3-3-3. Height of Cylinder Head Tightening Bolt

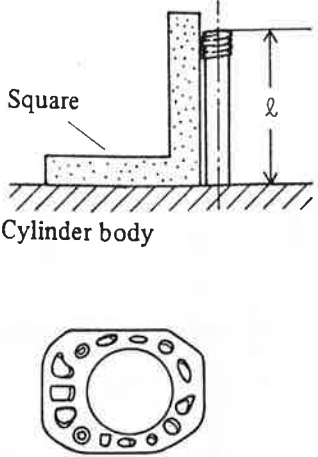
Measuring position	Remarks	Measuring Instrument								
 <p>Square</p> <p>Cylinder body</p> <p>l</p>	<p>Stud bolt Losseness standard for Stud bolts</p> <table border="1" data-bbox="837 411 1169 604"> <thead> <tr> <th>Stud bolt</th> <th>Length (mm)</th> </tr> </thead> <tbody> <tr> <td>A,B,C,D</td> <td>About</td> </tr> <tr> <td></td> <td>SVE8 95</td> </tr> <tr> <td></td> <td>SVE12 107</td> </tr> </tbody> </table> <p>When stud bolts are found to be too loose, retighten them.</p> <p>Tightening torque: 4.5 kg-m</p>	Stud bolt	Length (mm)	A,B,C,D	About		SVE8 95		SVE12 107	<p>Square</p> <p>Ruler</p> <p>Torque meter</p>
Stud bolt	Length (mm)									
A,B,C,D	About									
	SVE8 95									
	SVE12 107									

3-3-4. Crankshaft and Bearing

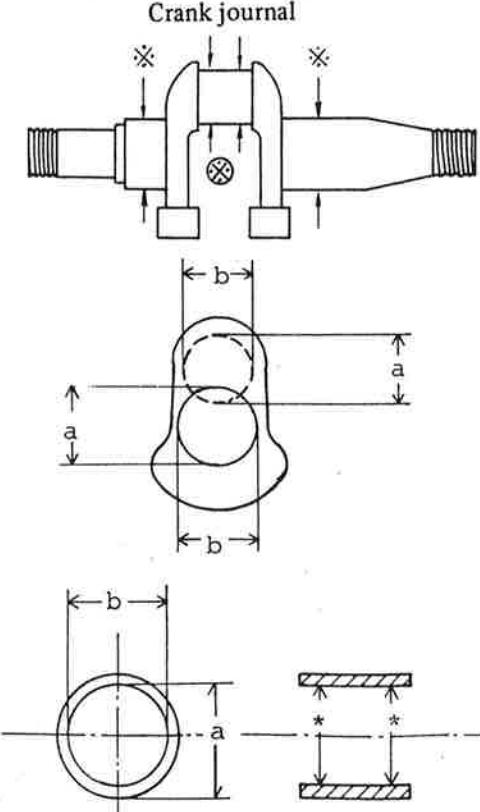
Measuring position	Remarks	Measuring Instrument
 <p>Crank journal</p> <p>Don't take the bearing out of the cylinder body.</p>	<p>Maximum wear dimension measured at * mark in (a) (b) directions.</p> <ul style="list-style-type: none"> <li>• Crank journal <ul style="list-style-type: none"> <li>Nominal size SVE8 SVE12 42 mm 52 mm</li> <li>Limit of use -0.13 -0.16</li> </ul> </li> <li>• Crank pin <ul style="list-style-type: none"> <li>Nominal size 42 mm 46 mm</li> <li>Limit of use -0.13 -0.14</li> </ul> </li> </ul> <p>Measure in horizontal and vertical directions at position,</p> <p>Nominal size SVE8 SVE12 44mm 52mm</p> <p>Limit of use +0.11 +0.13</p>	<p>Cylinder gauge</p>

## Replacement of main bearing metal:

### 1. Pulling of main bearing metal

As shown in the figure, attach the metal pullout device to the main bearing metal, and pull it out by tightening the nut.

Note that the metal should be pulled from the inside toward the outside of the engine.  
Metal fitting (B) is not used.

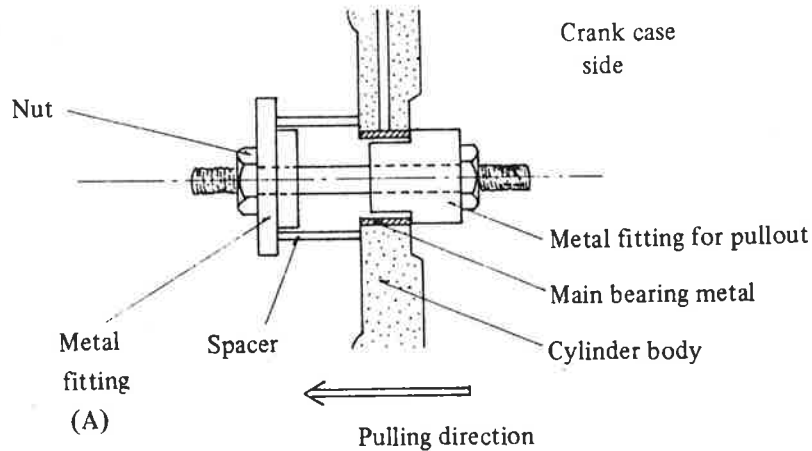

### 2. Insertion of crank gear side main bearing metal

2-1 Clean the area of the cylinder body in which the main bearing metal is to be inserted.

2-2 Rearrange the metal pullout device for insertion use.

2-3 Put the metal properly in the device so that its rounded corner part is directed to the cylinder body side.

2-4 Set the insertion device together with the main bearing metal into the cylinder body, and tighten the nuts until the metal goes in flush.

Note: That the main bearing metal should be inserted from the inside to the outside of the engine.

Care must also be exercised in this operation so that the lubrication hole of the engine body coincides with that of the main bearing metal.

- 2-5 After the insertion of the metal is completed, set the crank shaft in and make sure that the shaft turns smoothly.

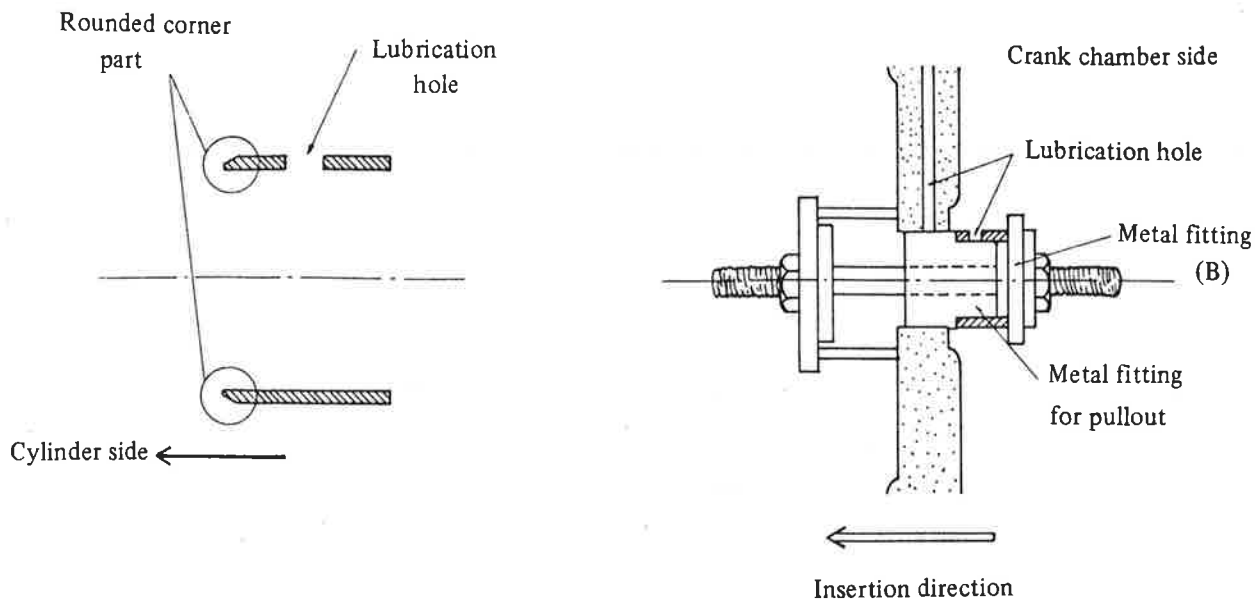

### 3. Extraction of Clutch Side Main Bearing Metal

- 3-1. Tap out the crank shaft oil seal with a Phillips screwdriver and a hammer, working from the crankcase side to the clutch case side.



3-2. Apply a metallic or wooden tapping block to the oil seal side of the crank metal and tap out the seal.

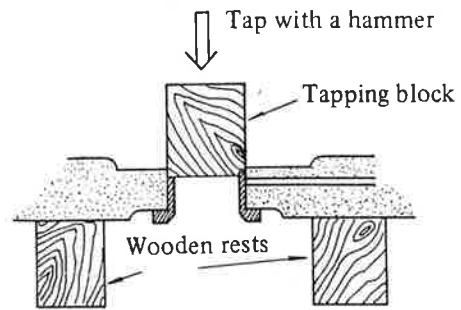
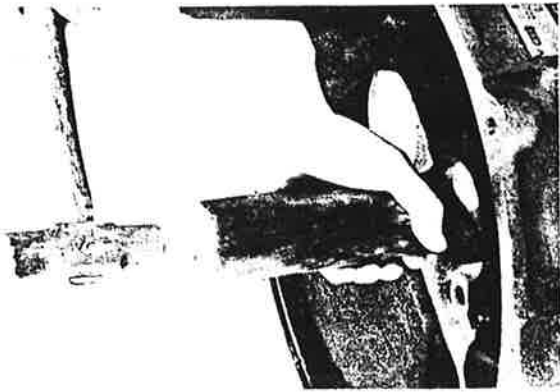

#### 4. Insertion of the Clutch Side Main Bearing Metal

4-1. Tap into place using a hammer and tapping block in the same way as the above item 3-2.

(Note) Align the dowel pin with dowel pin groove

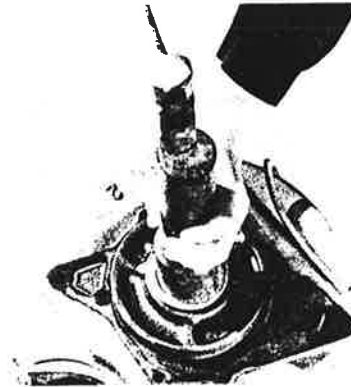

4-2. Fitting the oil seal

(Note) Replace with a new one and apply grease to lip.

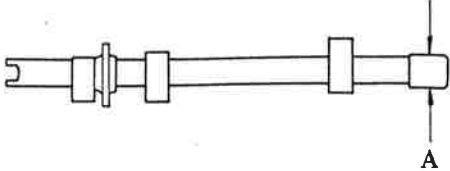
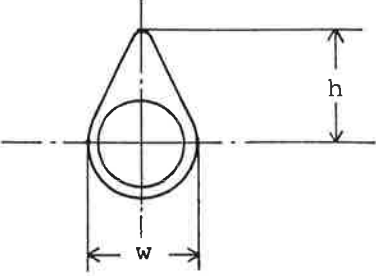
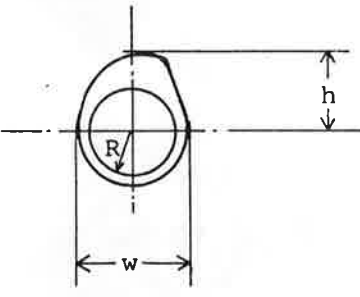
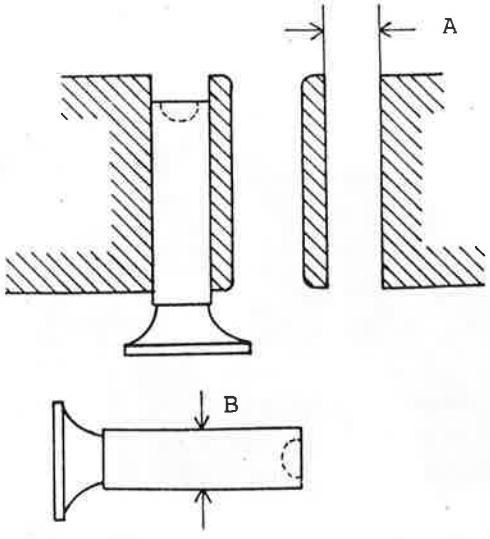

3-3-5. Cam Shaft and Tappet

Measuring position	Remarks	Measuring Instrument																		
 <p>Intake and Exhaust cam</p>	<p>Portion A</p> <table border="0"> <tr> <td></td> <td>SVE8</td> <td>SVE12</td> </tr> <tr> <td>Nominal size</td> <td>22mm</td> <td>24mm</td> </tr> <tr> <td>Limit of use</td> <td>-0.15</td> <td>-0.15</td> </tr> </table>		SVE8	SVE12	Nominal size	22mm	24mm	Limit of use	-0.15	-0.15	<p>Micrometer</p>									
	SVE8	SVE12																		
Nominal size	22mm	24mm																		
Limit of use	-0.15	-0.15																		
 <p>Fuel cam</p>	<table border="0"> <tr> <td>Nominal size</td> <td>SVE8</td> <td>SVE12</td> </tr> <tr> <td>w: mm</td> <td>25</td> <td>28</td> </tr> <tr> <td>h: mm</td> <td>18.3</td> <td>20.5</td> </tr> <tr> <td>Limit of use</td> <td></td> <td></td> </tr> <tr> <td>w: mm</td> <td>-0.2</td> <td>-0.2</td> </tr> <tr> <td>h: mm</td> <td>-0.1</td> <td>-0.1</td> </tr> </table>	Nominal size	SVE8	SVE12	w: mm	25	28	h: mm	18.3	20.5	Limit of use			w: mm	-0.2	-0.2	h: mm	-0.1	-0.1	<p>Micrometer Cylinder gauge</p>
Nominal size	SVE8	SVE12																		
w: mm	25	28																		
h: mm	18.3	20.5																		
Limit of use																				
w: mm	-0.2	-0.2																		
h: mm	-0.1	-0.1																		
	<table border="0"> <tr> <td>Nominal size</td> <td>SVE8</td> <td>SVE12</td> </tr> <tr> <td>w: mm</td> <td>60</td> <td>60</td> </tr> <tr> <td>h: mm</td> <td>33.5</td> <td>33.5</td> </tr> <tr> <td>Limit of use</td> <td></td> <td></td> </tr> <tr> <td>w: mm</td> <td>-0.2</td> <td>-0.2</td> </tr> <tr> <td>h: mm</td> <td>-0.1</td> <td>-0.1</td> </tr> </table>	Nominal size	SVE8	SVE12	w: mm	60	60	h: mm	33.5	33.5	Limit of use			w: mm	-0.2	-0.2	h: mm	-0.1	-0.1	
Nominal size	SVE8	SVE12																		
w: mm	60	60																		
h: mm	33.5	33.5																		
Limit of use																				
w: mm	-0.2	-0.2																		
h: mm	-0.1	-0.1																		
	<p>Inner diameter of tappet guide (A)</p> <table border="0"> <tr> <td></td> <td>SVE8</td> <td>SVE12</td> </tr> <tr> <td>Nominal size: mm</td> <td>10</td> <td>11</td> </tr> <tr> <td>Limit of use: mm</td> <td>+0.1</td> <td>+0.1</td> </tr> </table> <p>Outer diameter of tappet guide (B)</p> <table border="0"> <tr> <td></td> <td>SVE8</td> <td>SVE12</td> </tr> <tr> <td>Nominal size: mm</td> <td>10</td> <td>11</td> </tr> <tr> <td>Limit of use: mm</td> <td>-0.1</td> <td>-0.1</td> </tr> </table>		SVE8	SVE12	Nominal size: mm	10	11	Limit of use: mm	+0.1	+0.1		SVE8	SVE12	Nominal size: mm	10	11	Limit of use: mm	-0.1	-0.1	
	SVE8	SVE12																		
Nominal size: mm	10	11																		
Limit of use: mm	+0.1	+0.1																		
	SVE8	SVE12																		
Nominal size: mm	10	11																		
Limit of use: mm	-0.1	-0.1																		

3-3-6. Piston, Piston ring and Piston pin

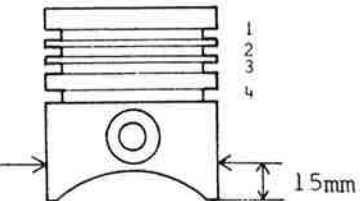
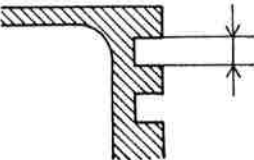
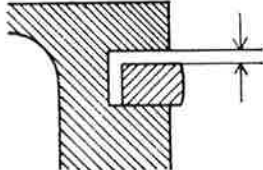
Measuring position	Remarks	Measuring Instrument
  	<p>Measure piston skirt</p> <p>SVE8 SVE12</p> <p>Nominal size: mm 75 85</p> <p>Limit of use: mm -0.23 -0.26</p> <p>Width of ring above</p> <p>1st compression ring</p> <p>SVE8 SVE12</p> <p>Nominal size: mm 2 2.5</p> <p>Limit of use: mm +0.15 +0.15</p> <p>2nd, 3rd compression ring</p> <p>Nominal size: mm 2 2.5</p> <p>Limit of use: mm +0.15 +0.15</p> <p>Oil scraping ring</p> <p>Nominal size: mm 4 4</p> <p>Limit of use: mm +0.15 +0.15</p> <p>Maximum clearance between ring and groove</p> <p>1st compression ring</p> <p>Standard clearance of ass'y 0.037 mm</p> <p>Limit of use 0.3 mm</p>	<p>Micrometer</p> <p>Thickness gauge</p> <p>Thickness gauge</p>

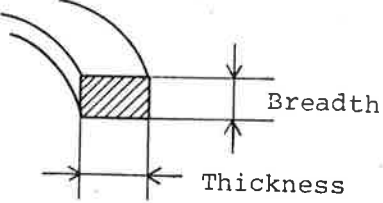
Measuring position	Remarks	Measuring Instrument																											
 <p>The diagram shows a cross-section of a piston ring. The ring is shaded with diagonal lines. Two dimensions are indicated: 'Breadth' is the width of the ring, and 'Thickness' is the radial thickness of the ring. The ring is shown in contact with a curved surface, likely the cylinder wall.</p>	<p>2nd, 3rd compression ring</p> <p>Standard clearance of ass'y 0.037 mm</p> <p>Limit of use 0.2 mm</p> <p>Oil scraping ring</p> <p>Standard clearance of ass'y 0.037 mm</p> <p>Limit of use 0.15 mm</p> <p><b>Piston ring</b></p> <p>Thickness and breadth of piston ring</p> <ul style="list-style-type: none"> <li><b>Breadth</b></li> </ul> <p>1st compression ring</p> <table border="0" data-bbox="812 1029 1234 1176"> <tr> <td></td> <td>SVE8</td> <td>SVE12</td> </tr> <tr> <td>Nominal size</td> <td>2mm</td> <td>2.5mm</td> </tr> <tr> <td>Limit of use</td> <td>-0.15mm</td> <td>-0.15mm</td> </tr> </table> <p>2nd, 3rd compression ring</p> <table border="0" data-bbox="812 1281 1234 1407"> <tr> <td>Nominal size</td> <td>2mm</td> <td>2.5mm</td> </tr> <tr> <td>Limit of use</td> <td>-0.15mm</td> <td>-0.15mm</td> </tr> </table> <p>Oil scraping ring</p> <table border="0" data-bbox="812 1512 1234 1638"> <tr> <td>Nominal size</td> <td>4mm</td> <td>4mm</td> </tr> <tr> <td>Limit of use</td> <td>-0.15mm</td> <td>-0.15mm</td> </tr> </table> <ul style="list-style-type: none"> <li><b>Thickness</b></li> </ul> <p>1st compression ring</p> <table border="0" data-bbox="812 1806 1234 1932"> <tr> <td>Nominal size</td> <td>3.3mm</td> <td>3.7mm</td> </tr> <tr> <td>Limit of use</td> <td>-0.33mm</td> <td>-0.37mm</td> </tr> </table>		SVE8	SVE12	Nominal size	2mm	2.5mm	Limit of use	-0.15mm	-0.15mm	Nominal size	2mm	2.5mm	Limit of use	-0.15mm	-0.15mm	Nominal size	4mm	4mm	Limit of use	-0.15mm	-0.15mm	Nominal size	3.3mm	3.7mm	Limit of use	-0.33mm	-0.37mm	<p>Micrometer</p>
		SVE8	SVE12																										
	Nominal size	2mm	2.5mm																										
	Limit of use	-0.15mm	-0.15mm																										
	Nominal size	2mm	2.5mm																										
	Limit of use	-0.15mm	-0.15mm																										
	Nominal size	4mm	4mm																										
	Limit of use	-0.15mm	-0.15mm																										
	Nominal size	3.3mm	3.7mm																										
	Limit of use	-0.33mm	-0.37mm																										

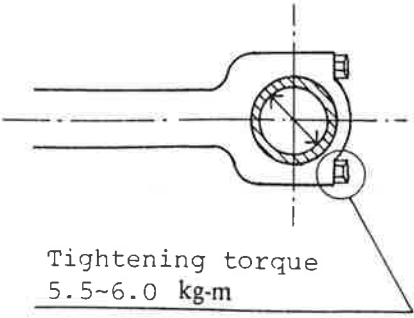

Measuring position	Remarks	Measuring Instrument
 <p data-bbox="282 562 558 625">Tightening torque 5.5~6.0 kg-m</p>	<p data-bbox="753 260 1175 323">Maximum inner diameter measured in horizontal and vertical directions</p> <p data-bbox="786 373 1159 401">Nominal size    42mm    36mm</p> <p data-bbox="786 449 1192 476">Limit of use     +0.11mm +0.12mm</p>	<p data-bbox="1273 268 1435 296">Cylinder gauge</p>

#### Pulling and insertion of piston pin

The piston is coupled to the connecting rod through the piston pin. Normally, the piston pin hole has some tightening margin in a cold condition. In order to ease the operations of pullout and insertion of the piston pin, the piston must be heated.

1. Remove the two circlip of the piston pin.
2. Warm the piston in an oil bath maintained at about 80°C for approximately 15 minutes.
3. Pull out the piston pin, using the pullout implement for piston pin.



In the same manner, when the piston is coupled to the connecting rod, heat the piston only.

3-3-8. Valve Mechanism

Intake and Exhaust valve, valve guide

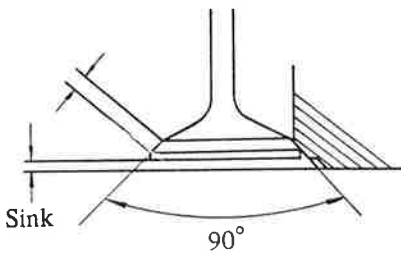
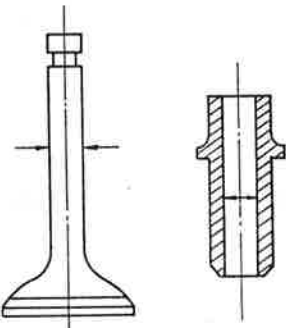
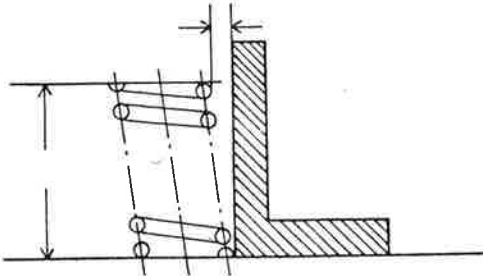
Measuring position	Remarks	Measuring Instrument															
<p style="text-align: center;">Valve seat width</p>  <p style="text-align: center;">Sink</p> <p style="text-align: center;">90°</p>	<p>Intake and exhaust valve seat width</p> <table border="0"> <tr> <td></td> <td style="text-align: center;">SVE8</td> <td style="text-align: center;">SVE12</td> </tr> <tr> <td>Nominal size</td> <td style="text-align: center;">2.8mm</td> <td style="text-align: center;">3.5mm</td> </tr> <tr> <td>Limit of use</td> <td style="text-align: center;">3.2mm</td> <td style="text-align: center;">3.9mm</td> </tr> </table> <p>Sink</p> <table border="0"> <tr> <td>Nominal size</td> <td style="text-align: center;">1.25mm</td> <td style="text-align: center;">1.25 mm</td> </tr> <tr> <td>Limit of use</td> <td style="text-align: center;">-0.5mm</td> <td style="text-align: center;">-0.5mm</td> </tr> </table>		SVE8	SVE12	Nominal size	2.8mm	3.5mm	Limit of use	3.2mm	3.9mm	Nominal size	1.25mm	1.25 mm	Limit of use	-0.5mm	-0.5mm	
	SVE8	SVE12															
Nominal size	2.8mm	3.5mm															
Limit of use	3.2mm	3.9mm															
Nominal size	1.25mm	1.25 mm															
Limit of use	-0.5mm	-0.5mm															
 <p style="text-align: center;">Valve stem      Valve guide</p>	<p>Intake and exhaust valve stem.</p> <table border="0"> <tr> <td></td> <td style="text-align: center;">SVE8</td> <td style="text-align: center;">SVE12</td> </tr> <tr> <td>Nominal size</td> <td style="text-align: center;">7mm</td> <td style="text-align: center;">8mm</td> </tr> <tr> <td>Limit of use</td> <td style="text-align: center;">-0.1mm</td> <td style="text-align: center;">-0.1mm</td> </tr> </table>		SVE8	SVE12	Nominal size	7mm	8mm	Limit of use	-0.1mm	-0.1mm	<p>Micrometer</p>						
	SVE8	SVE12															
Nominal size	7mm	8mm															
Limit of use	-0.1mm	-0.1mm															
	<p>Intake and exhaust valve guide</p> <table border="0"> <tr> <td></td> <td style="text-align: center;">SVE8</td> <td style="text-align: center;">SVE12</td> </tr> <tr> <td>Nominal size</td> <td style="text-align: center;">7mm</td> <td style="text-align: center;">8mm</td> </tr> <tr> <td>Limit of use</td> <td style="text-align: center;">+0.1mm</td> <td style="text-align: center;">+0.1mm</td> </tr> </table>		SVE8	SVE12	Nominal size	7mm	8mm	Limit of use	+0.1mm	+0.1mm	<p>Innder diameter micrometer</p>						
	SVE8	SVE12															
Nominal size	7mm	8mm															
Limit of use	+0.1mm	+0.1mm															
 <p style="text-align: center;">Spring constant</p> <p style="text-align: center;">SVE8 1.58 Kg/mm</p> <p style="text-align: center;">SVE12 2.26 Kg/mm</p>	<p>Spring free length</p> <table border="0"> <tr> <td></td> <td style="text-align: center;">SVE8</td> <td style="text-align: center;">SVE12</td> </tr> <tr> <td>Nominal size</td> <td style="text-align: center;">41mm</td> <td style="text-align: center;">40mm</td> </tr> <tr> <td>Limit of use</td> <td style="text-align: center;">2mm</td> <td style="text-align: center;">2mm</td> </tr> </table> <p>Spring inclination</p> <table border="0"> <tr> <td>Limit of use</td> <td style="text-align: center;">1.5mm</td> <td style="text-align: center;">1.5mm</td> </tr> </table>		SVE8	SVE12	Nominal size	41mm	40mm	Limit of use	2mm	2mm	Limit of use	1.5mm	1.5mm	<p>Square</p> <p>Slide calipers</p>			
	SVE8	SVE12															
Nominal size	41mm	40mm															
Limit of use	2mm	2mm															
Limit of use	1.5mm	1.5mm															

Remove the intake & exhaust valve with the valve lifter

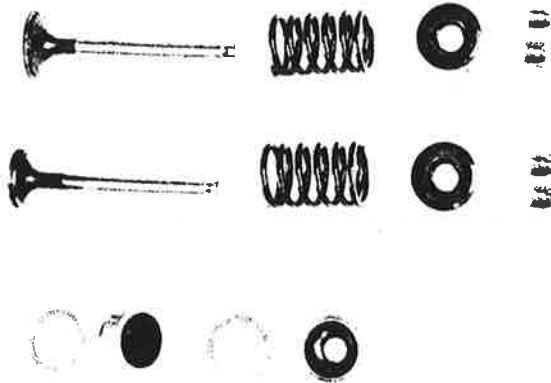

Rocker arm

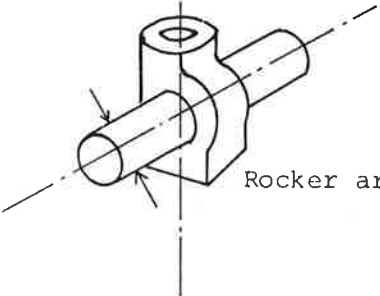
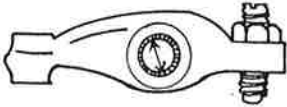
Measuring position	Remarks		Measuring Instrument
 <p>Rocker arm support</p>	Nominal size	SVE8 12mm    SVE12 16mm	Micrometer
	Limit of use	-0.1    -0.1	
 <p>Rocker arm brush</p>	Nominal size	12mm    16mm	Cylinder gauge
	Limit of use	+0.1    +0.1	

3-3-9. Fuel injection pump and Nozzle

See page 70 ~ 73.

3-3-10. Cooling Water Pump

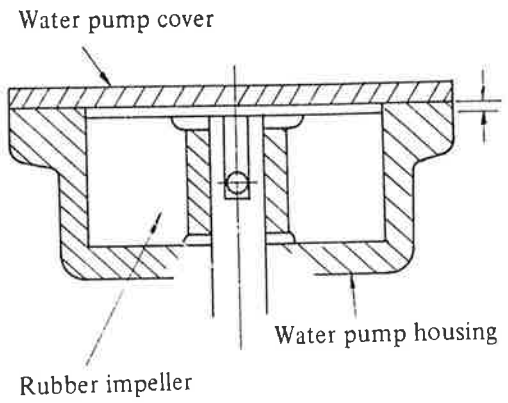
Measuring position	Remarks	Measuring Instrument
	<p>Clearance between rubber impeller and water pump cover.</p> <p>When the clearance is 0.5 mm or more, replace the impeller.</p>	<p>Thickness gauge</p> <p>Ruler</p>

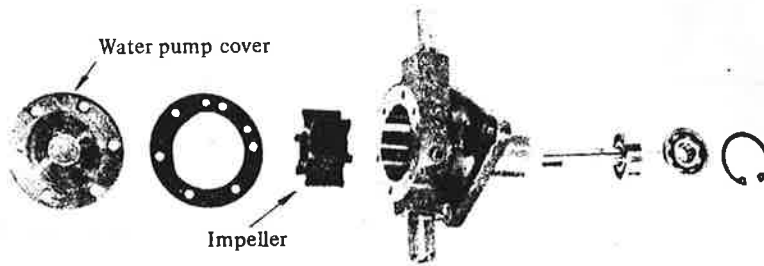

3-3-11. Friction Disc and Reduction Gears

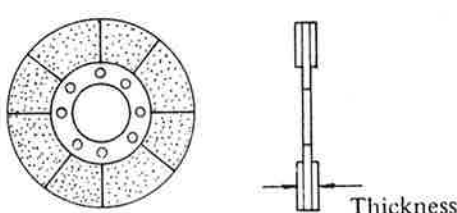
Measuring position	Remarks	Measuring Instruction
	<p>Thickness of friction disc.</p> <p>Nominal size <math>6 \begin{matrix} +0.3 \\ 0 \end{matrix} \text{ mm}</math></p> <p>Limit of use <math>-1.5 \text{ mm}</math></p> <p>Check each reduction gear visually for its degree of contact.</p> <p>Refer to Page 65 for disassembly and reassembly of the clutch.</p>	<p>Micrometer or Vernier Caliper</p>

### 3-3-12. Fuel Oil Feed Pump

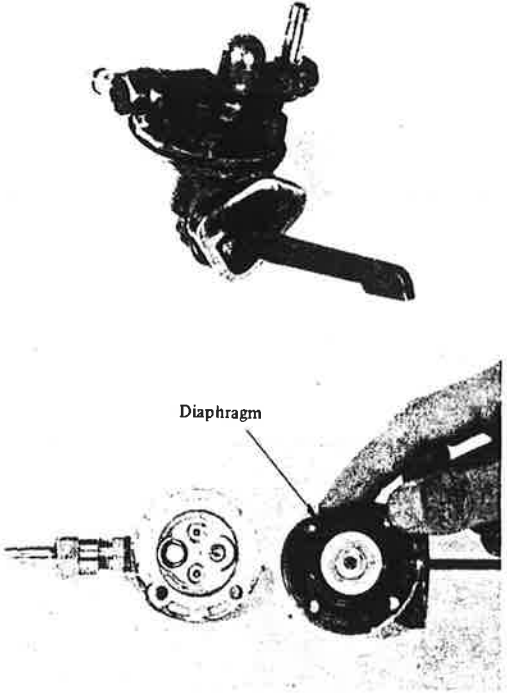
Measuring position	Remarks	Measuring Instrument
 <p>The image shows a person in a dark jacket inspecting a fuel oil feed pump. Below this, a close-up shows a hand holding a circular diaphragm component. A label 'Diaphragm' with a pointer indicates the part being inspected.</p>	<p>Check the diaphragm for scratches or breaks</p> <p>If replacement is required, replace it as a set with the fuel oil feed pump.</p>	<p>Visual check</p>

### 3-3-13. Lube Oil Pump

Measuring position	Remarks	Measuring instrument
 <p>The top photograph shows a hand using a feeler gauge to measure the clearance between the pump cover and the inner rotor. The bottom photograph shows a hand using a feeler gauge to measure the clearance between the inner rotor and the outer rotor.</p>	<p>Clearance between the pump cover and inner rotor or outer rotor:</p> <p>Normal value 0.04mm</p> <p>Serviceable limit 0.10mm</p> <p>Clearance between the inner rotor and outer rotor:</p> <p>Normal value 0.03mm 0.07mm</p> <p>Serviceable limit 0.10mm</p>	<p>Measuring instrument</p>

## 3-4. Bolts, Nuts and Tightening Torques

Kg/cm

No.	Part	SVE8	SVE12
1	Cylinder head tightening bolt (stud)	M12 x 450	M14 x 450
2	Cylinder head tightening nut	12 x 970	14 x 1365
3	Gear case mounting	6 x 80	6 x 80
4	Side case mounting	8 x 200	8 x 200
5	Jacket cover mounting	8 x 200	10 x 430
6	Oil pan mounting	6 x 80	6 x 80
7	Mounting flange (inside)	8 x 200	8 x 200
8	Mounting flange (outside)	10 x 430	10 x 430
9	Engine leg mounting	8 x 200	10 x 430
10	Rocker arm support mounting	10 x 420	10 x 420
11	Intake pipe mounting	8 x 200	8 x 200
12	Exhaust silencer mounting	8 x 200	8 x 200
13	Exhaust elbow mounting	8 x 200	8 x 200
14	Inner pipe mounting	30 x 2000	30 x 2000
15	Camshaft main bearing binding screw	8 x 200	8 x 200
16	Crankshaft main bearing	8 x 200	8 x 200
17	End nut	30 x 2000 ~2500	36 x 2300 ~2700
18	Crank gear locking nut	36 x 3500 ~4000	36 x 3500 ~4000
19	PTO pulley mounting	12 x 700	12 x 700
20	Balance weight mounting	10 x 420	10 x 420
21	Connecting rod bolt	8 x 400	9 x 550
22	L.O. pump gear lock nut	12 x 500	12 x 500
23	Oil signal/Oil pressure switch	PT 1/8 x 100	PT 1/8 x 100
24	L.O. strainer	6 x 80	6 x 80
25	L.O. strainer casing	6 x 80	6 x 80
26	Oil pressure regulating valve body	14 x 300 ~350	14 x 300 ~350
27	L.O. suction pipe and nut	PF1/8 x 200	PF1/8 x 200
28	Anticorrosive zinc mounting	8 x 200	8 x 200
29	Thermostat switch	PT3/8 x 80 ~100	PT3/8 x 80 ~100
30	F.O. pump mounting	6 x 80	6 x 80
31	Governor weight support mounting	6 x 80	6 x 80
32	Starting shaft support mounting	8 x 200	8 x 200
33	Free wheel shaft lock nut	10 x 300	10 x 300

No.	Part	SVE8	SVE12
34	Camshaft locking nut (outer ring)	24 × 1500 L.H. screw	24 × 1500
35	Clutch case mounting	8 × 200	8 × 200
36	Friction plate housing (A, B) mounting	10 × 430	10 × 430
37	Friction plate mounting	8 × 170 ~200	8 × 170 ~200
38	Forward shaft locking nut	24 × 2000	24 × 2000
39	Shifter drive plate lock nut	12 × --	16 ×
40	Intermediate shaft lock	16 × 2000	16 × 2000
41	Thrust shaft lock nut	30 × 2000	30 × 2000
42	Shaft coupling lock nut (engine side)	16 × 2000	16 × 2000

### 3-5. Disassembly and Reassembly of Engine

#### 3-5-1. General Precautions

Maintenance and inspection activity should be done as effectively as possible, avoiding unnecessary disassembling except for general overhauls.



At the time of disassembly, record the presence of parts which require repair or replacement, and make arrangements beforehand for procurement of such parts so that problems will not occur during the reassembling operation.

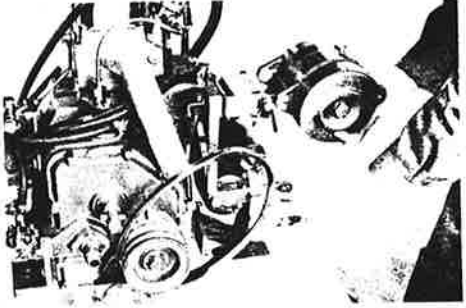
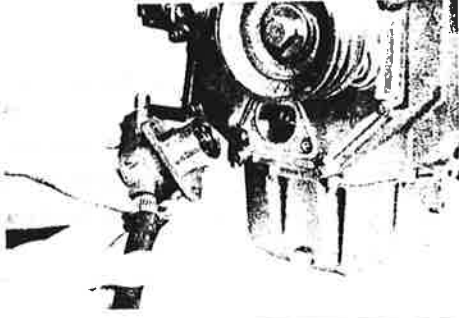
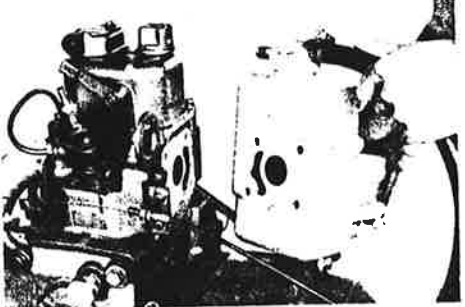
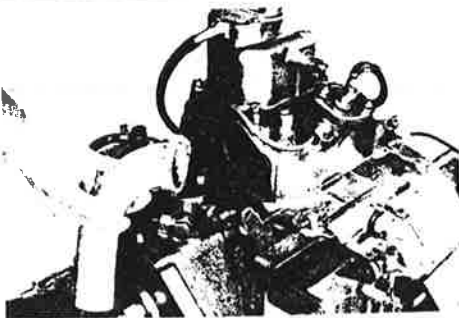

In assembling, sealing must be applied to all designated. Omission may cause serious trouble during a trial running of the engine after completion of reassembly. Adjustments should be performed in accordance with the instructions given.

After completion of engine reassembly, recheck any deficiencies which might have appeared during maintenance and inspection, conduct a trial running of the engine and then submit it to the user.

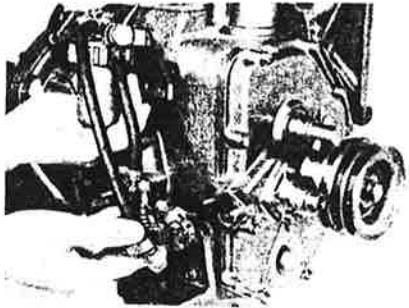
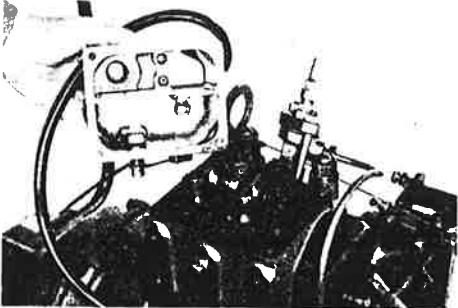
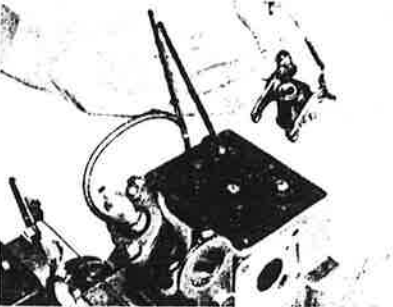
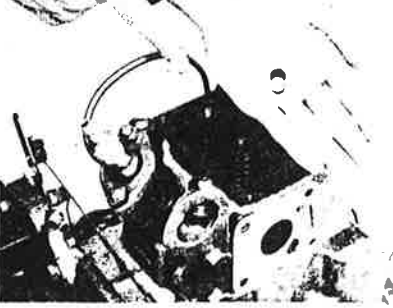
3-5-2. Disassembly Sequence

Item	Procedure	Illustration
1. Wiring, piping and wires	<ul style="list-style-type: none"> <li>Remove electrical wiring, cooling water piping, and remote control wires connected to the engine.</li> </ul>	
	<ul style="list-style-type: none"> <li>Remove cooling water and lube oil.</li> </ul>	
2. Electrical provisions	<ul style="list-style-type: none"> <li>Remove the starting motor</li> <li>Loosen the alternator tension and remove V-belt.</li> <li>Remove the alternator and stay.</li> </ul>	
3. Cooling water pump	<ul style="list-style-type: none"> <li>Remove the cooling water pipe</li> <li>Remove the cooling water pump</li> </ul>	
4. Silencer	<ul style="list-style-type: none"> <li>Remove the cooling water pipe and silencer</li> </ul>	
5. Intake pipe	<ul style="list-style-type: none"> <li>Remove the intake pipe</li> </ul>	

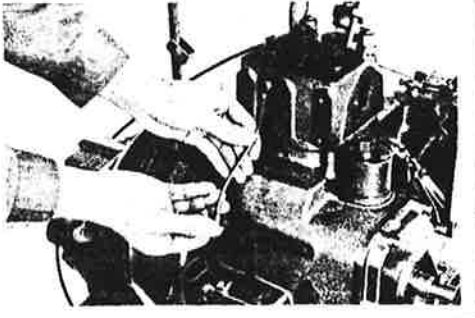
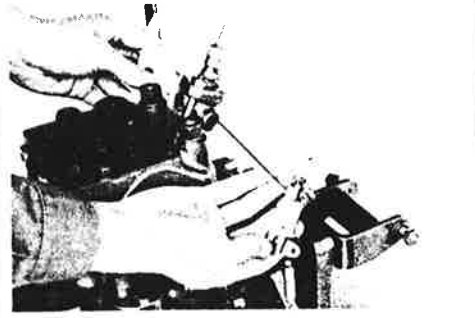
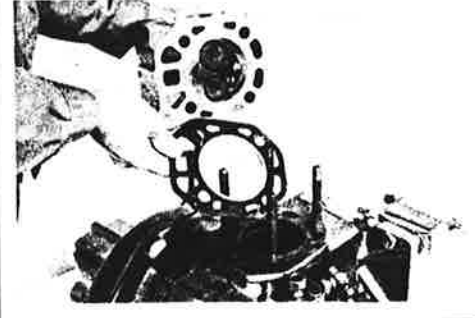
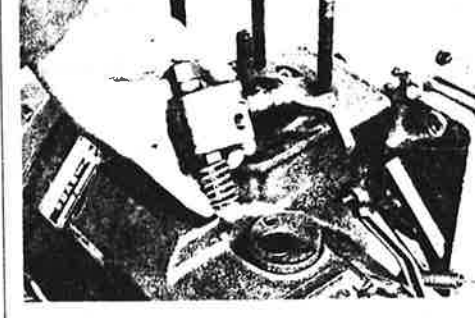
Item	Procedure	Illustration
6. Fuel feed pump	<ul style="list-style-type: none"> <li>• Remove the fuel strainer fitting bolts</li> <li>• Remove the feed pump together with strainer</li> </ul>	
7. Rocker arm cover	<ul style="list-style-type: none"> <li>• Remove the rocker arm cover</li> </ul>	
8. Rocker arm	<ul style="list-style-type: none"> <li>• Remove rocker arm</li> <li>• Remove valve push rods (Make an indication to distinguish between top and bottom, intake and exhaust push rods.)</li> </ul>	
	<ul style="list-style-type: none"> <li>• Remove protectors of intake and exhaust valve heads.</li> </ul>	
9. Fuel injection pipe	<ul style="list-style-type: none"> <li>• Remove the fuel injection pipe.</li> </ul>	



Item	Procedure	Illustration
10. Lube oil pipe	<ul style="list-style-type: none"> <li>• Be sure not to forget the pipe fixing bolt's copper packings.</li> </ul>	
11. Regulator lever	<ul style="list-style-type: none"> <li>• Remove the regulator lever, remote control wire and engine lift bracket as an assembly.</li> </ul>	
12. Cylinder head	<ul style="list-style-type: none"> <li>• Remove the cylinder head.</li> <li>• Before touching the gasket packing, distinguish between front and back, right and left sides.</li> </ul>	
13. Fuel injection pump	<ul style="list-style-type: none"> <li>• Remove the fuel injection pump. (Be sure not to neglect small parts such as plunger spring, washer, etc.)</li> <li>• Remove the fuel injection pump mount. (Be sure not to neglect injection timing adjusting shims.)</li> </ul>	 

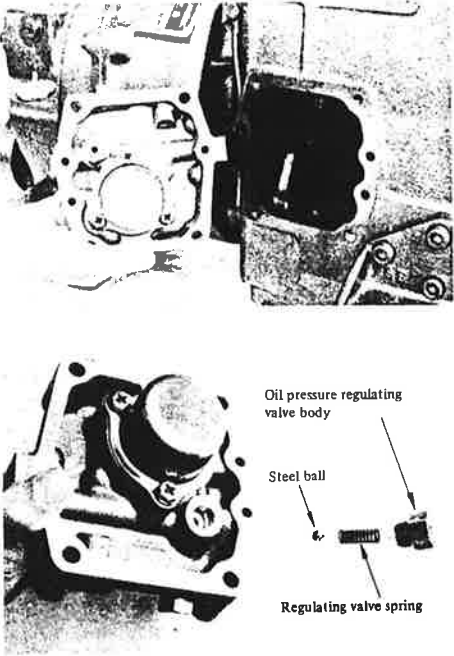
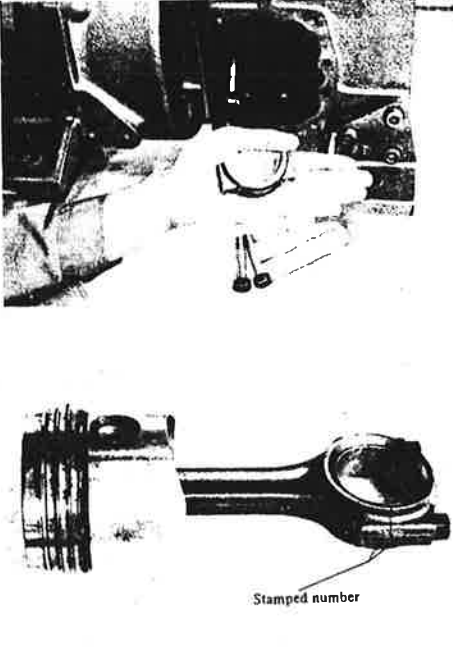
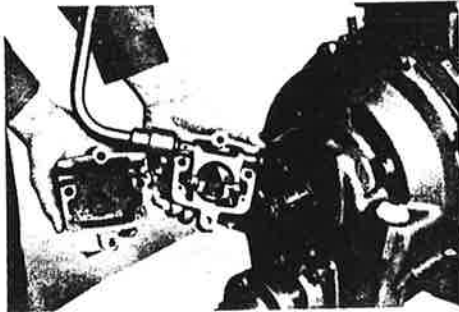

Item	Procedure	Illustration
18. Side case	<ul style="list-style-type: none"> <li>• Pull out the oil level gauge stick.</li> <li>• Remove the side case.</li>   <li>• Check the oil pressure regulating valve for damages, etc. Secure tightly after cleaning.</li> </ul>	
19. Piston	<ul style="list-style-type: none"> <li>• Disassemble the large end of the connecting rod.</li>   <li>• Pull out the piston</li> <li>• Confirm alignment marks (number) on the large end.</li> </ul>	
20. Clutch	<ul style="list-style-type: none"> <li>• Remove the forward shaft rear cover and clutch lever assembly.</li> </ul>	

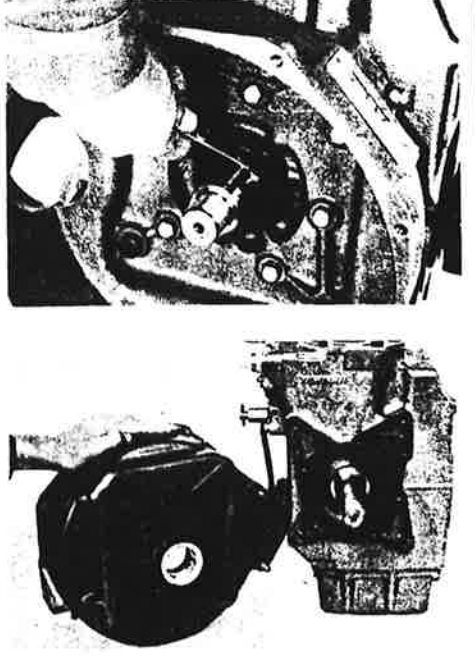
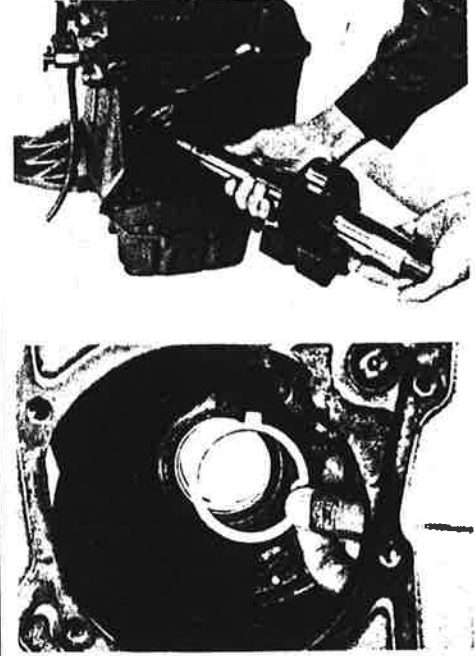
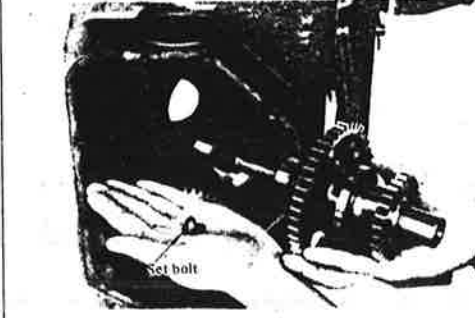

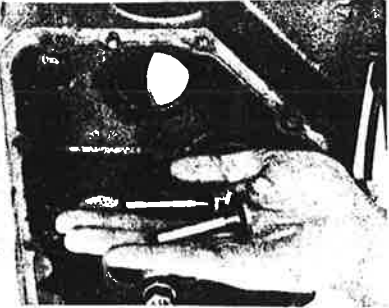
Item	Procedure	Illustration
	<ul style="list-style-type: none"> <li>• Be sure not to neglect the setting pin and neutral position spring.</li>   <li>• Remove the clutch case.</li>   <li>• Do not remove the intermediate gear shaft nut.</li>   <li>• Remove the clutch assembly.</li>   <li>• Remove the flywheel.</li>   <li>• Be sure to use the extractor.</li> </ul>	

Item	Procedure	Illustration
	<ul style="list-style-type: none"> <li>• Remove the crankshaft key.</li>   <li>• Remove the mounting flange.</li>   <li>• Be careful not to neglect the breather baffle board.</li> </ul>	 <p>The top photograph shows a close-up of the crankshaft key being removed from the crankshaft. The bottom photograph shows the mounting flange and breather baffle board being removed from the engine block.</p>
21. Crankshaft	<ul style="list-style-type: none"> <li>• Pull out the crankshaft.</li>   <li>• Remove the crank gear.</li>   <li>• Remove the thrust metal.</li>   <li>• Make an indication to distinguish between both sides.</li> </ul>	 <p>The top photograph shows a person using a tool to pull out the crankshaft from the engine block. The bottom photograph shows the crankshaft with the crank gear removed, and a mark is made on the crankshaft to distinguish between both sides.</p>
22. Camshaft, tappet	<ul style="list-style-type: none"> <li>• Remove the set bolt and tap out with a Phillips screwdriver and hammer.</li> </ul>	 <p>The photograph shows a person using a Phillips screwdriver and hammer to tap out the set bolt from the camshaft. The set bolt is labeled in the image.</p>

Item	Procedure	Illustration
	<ul style="list-style-type: none"><li>• Pull out tappets.</li></ul>	
23. Lube oil pump	<ul style="list-style-type: none"><li>• Remove together with the drive gear.</li></ul>	

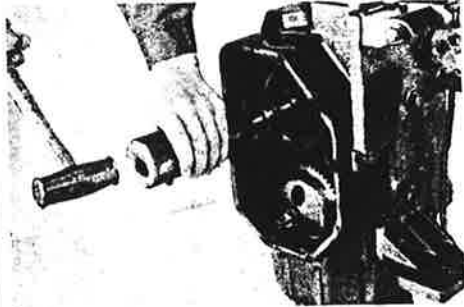
3-5-3. Reassembly Sequence

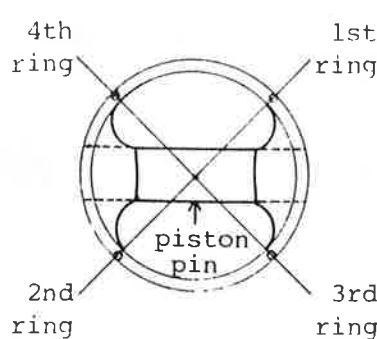
Item	Procedure	Illustration
1. Lube oil pump	<ul style="list-style-type: none"> <li>• Install the lube oil pump.</li> <li>• Paper packings</li> </ul>	
2. Tappet	<ul style="list-style-type: none"> <li>• Insert tappet</li> <li>• Make an indication to distinguish between intake and exhaust sides.</li> </ul>	
3. Camshaft	<ul style="list-style-type: none"> <li>• Put in the camshaft.</li> <li>• Tap into place with a hammer and tapping block.</li> <li>• Confirm revolving condition</li> <li>• Secure the set bolt.</li> </ul>	
4. Crankshaft	<ul style="list-style-type: none"> <li>• Put in the thrust bearing.</li> <li>• Mark to distinguish between both sides.</li> <li>• Take special care regarding the protruding portion.</li> <li>• Put in the crankshaft.</li> <li>• Fix the mounting flange.</li> <li>• Take care regarding the position of the breather baffle board.</li> <li>• After fixing the flange, confirm the turning condition of the crank shaft.</li> <li>• Paper packings.</li> </ul>	
5. Flywheel	<ul style="list-style-type: none"> <li>• Insert the crankshaft key.</li> <li>• Mount the flywheel.</li> <li>• Do not tap with a hammer.</li> <li>• Tighten the end nut firmly with the nut spanner and hammer.</li> <li>• Confirm revolving condition.</li> </ul>	

Item	Procedure	Illustration
<p>6. Piston</p>	<ul style="list-style-type: none"> <li>• Put in piston. <ul style="list-style-type: none"> <li>• Confirm insertion of the crankpin metal.</li> </ul> </li> <li>• Confirm the number on the large end connection rod.</li> <li>• Arrange each piston ring open end as shown in the following figure. <div style="text-align: center; margin: 10px 0;">  </div> </li> <li>• Tighten the connecting bolts.</li> <li>• Make sure to check the tightening torque. <p style="margin-left: 40px;">Torque: 5.5 ~ 6.0 kg-m.</p> </li> </ul>	
<p>7. Clutch</p>	<ul style="list-style-type: none"> <li>• Install the clutch assembly.</li> <li>• Attach the clutch case.</li> <li>• Attach the forward shaft rear cover and clutch lever assembly. <ul style="list-style-type: none"> <li>• Paper packings</li> </ul> </li> </ul>	
<p>8. Side case</p>	<ul style="list-style-type: none"> <li>• Attach side case. <ul style="list-style-type: none"> <li>• Paper packings</li> </ul> </li> <li>• Attach the forward shaft rear cover and clutch lever assembly.</li> </ul>	

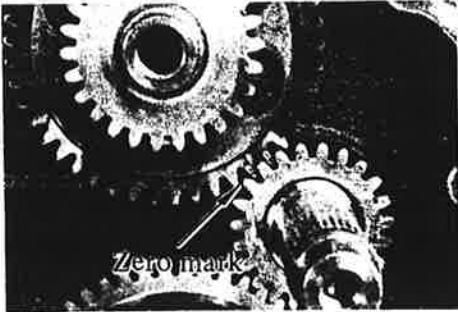
Item	Procedure	Illustration
9. Crank gear	<ul style="list-style-type: none"> <li>• Mount the crank gear. <ul style="list-style-type: none"> <li>• Align "O" mark with that of the cam gear.</li> <li>• "O" mark is not provided for alignment with the L.O. pump drive gear.</li> </ul> </li> <li>• Tighten crank gear clamping nuts.</li> <li>• Mark to distinguish between both sides of the nuts.</li> </ul>	
10. Governor.	<ul style="list-style-type: none"> <li>• Attach governor weight assembly.</li> <li>• Attach governor sleeve.</li> </ul>	
11. Gear case.	<ul style="list-style-type: none"> <li>• Assemble gear case. <ul style="list-style-type: none"> <li>• Make sure governor lever is in correct position.</li> <li>• Oil seals should be in good condition.</li> <li>• Use paper gaskets.</li> </ul> </li> <li>• Check rotation of flywheel.</li> <li>• Attach starter shaft.</li> <li>• Install key in PTO shaft.</li> <li>• Install V-belt pulley on PTO shaft.</li> </ul>	
12. Fuel injection pump.	<ul style="list-style-type: none"> <li>• Install fuel injection pump mount. <ul style="list-style-type: none"> <li>• Insert roller guides in proper position.</li> <li>• Do not forget the injection timing adjustment shims.</li> </ul> </li> <li>• Install fuel injection pump. <ul style="list-style-type: none"> <li>• Use paper gasket.</li> <li>• Install plunger, spring, and washer, properly.</li> <li>• Attach pump adjustment lever to connecting screw, properly.</li> </ul> </li> </ul>	

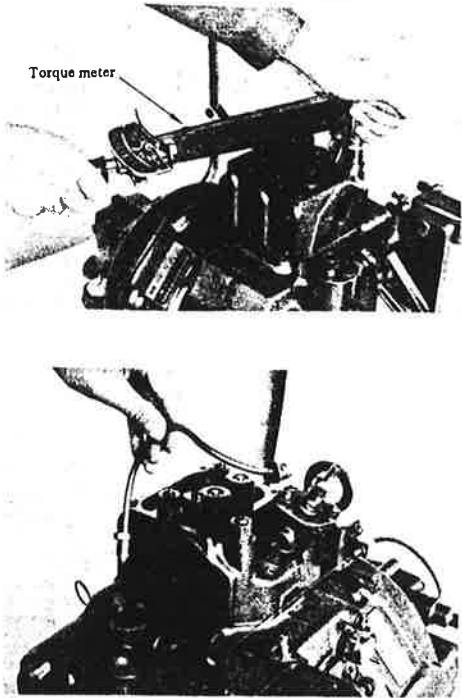
Item	Procedure	Illustration
13. Cylinder head.	<ul style="list-style-type: none"> <li>• Fit gasket, making sure that correct side is next to head and that holes in gasket are correctly aligned with mounting bolt holes in head and cylinder.</li> <li>• Mount cylinder head. <ul style="list-style-type: none"> <li>• Tightening torque: SVE8 = 8.8 kg-m SVE12 = 12</li> </ul> </li> <li>• Tighten bolts gradually, working across opposite corners.</li> <li>• Attach lube oil lines. <ul style="list-style-type: none"> <li>• Use copper gaskets.</li> </ul> </li> <li>• Attach engine lifting fittings, remote control cables, and accelerator lever.</li> <li>• Attach injection line.</li> </ul>	
14. Rocker arms.	<ul style="list-style-type: none"> <li>• Mount valve tip protectors.</li> <li>• Install push rods. <ul style="list-style-type: none"> <li>• Distinguish between intake and exhaust, and upper and lower ends.</li> </ul> </li> <li>• Attach rocker arms.</li> <li>• Attach rocker arm cover. <ul style="list-style-type: none"> <li>• Use paper gasket.</li> </ul> </li> </ul>	
15. Fuel filter.	<ul style="list-style-type: none"> <li>• Install fuel feed pump and fuel filter.</li> <li>• Attach fuel feed line to injection pump. <ul style="list-style-type: none"> <li>• Use copper gaskets.</li> </ul> </li> </ul>	
16. Intake pipe.	<ul style="list-style-type: none"> <li>• Attach intake pipe.</li> </ul>	

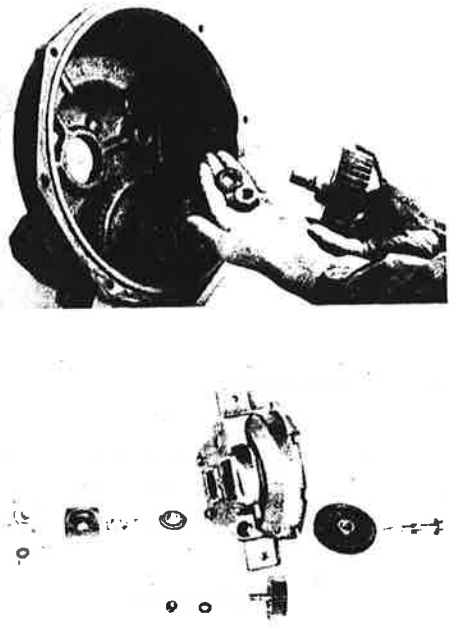

Item	Procedure	Illustration
	<ul style="list-style-type: none"> <li>• Straighten lock washer and remove locknut.</li>   <li>• Remove ball bearing.</li>   <li>• Remove housing (B). <ul style="list-style-type: none"> <li>• Including locating pin and springs</li> </ul> </li>   <li>• Remove the two clevis pins and swing clevis arms outward.</li> <li>• Remove ahead and astern friction plate assemblies.</li>   <li>• Remove shifting shaft assembly.</li> </ul>	

Item	Procedure	Illustration
2. Idler gear.	<ul style="list-style-type: none"> <li>• Remove mounting nut and washer.</li> <li>• Withdraw idler gear together with shaft.</li> </ul>	
3. Thrust shaft.	<ul style="list-style-type: none"> <li>• Remove thrust shaft.</li> <li>• Remove final reduction gear.</li> <li>• Do not misplace the key.</li> </ul>	

Reassembly of clutch speed reduction unit :

Item	Procedure	Illustration
1. Thrust shaft.	<ul style="list-style-type: none"> <li>• Install final reduction gear in clutch case.</li> <li>• Set key in thrust shaft.</li> <li>• Install thrust shaft.</li> <li>• Insert bearing.</li> </ul>	
2. Idler gear.	<ul style="list-style-type: none"> <li>• Use new O-ring on idler gear shaft.</li> <li>• Install idler gear/shaft assembly; tighten mounting nuts.</li> </ul>	

Item	Procedure	Illustration
3. Thrust shaft coupling.	<ul style="list-style-type: none"> <li>• Use new lockwasher.</li> <li>• Tighten mounting nut.               <ul style="list-style-type: none"> <li>• Distinguish between inside and outside faces.</li> </ul> </li> <li>• Install rear cover of thrust shaft.</li> <li>• Install thrust shaft key.</li> <li>• Install coupling.</li> <li>• After assembly is completed, check for ease of rotation of shafts.</li> </ul>	

**Fuel injection pump**

- Tools required: Wrenches (13 mm, 19 mm); off-set wrench (19mm); pallet for parts; kerosene for cleaning.

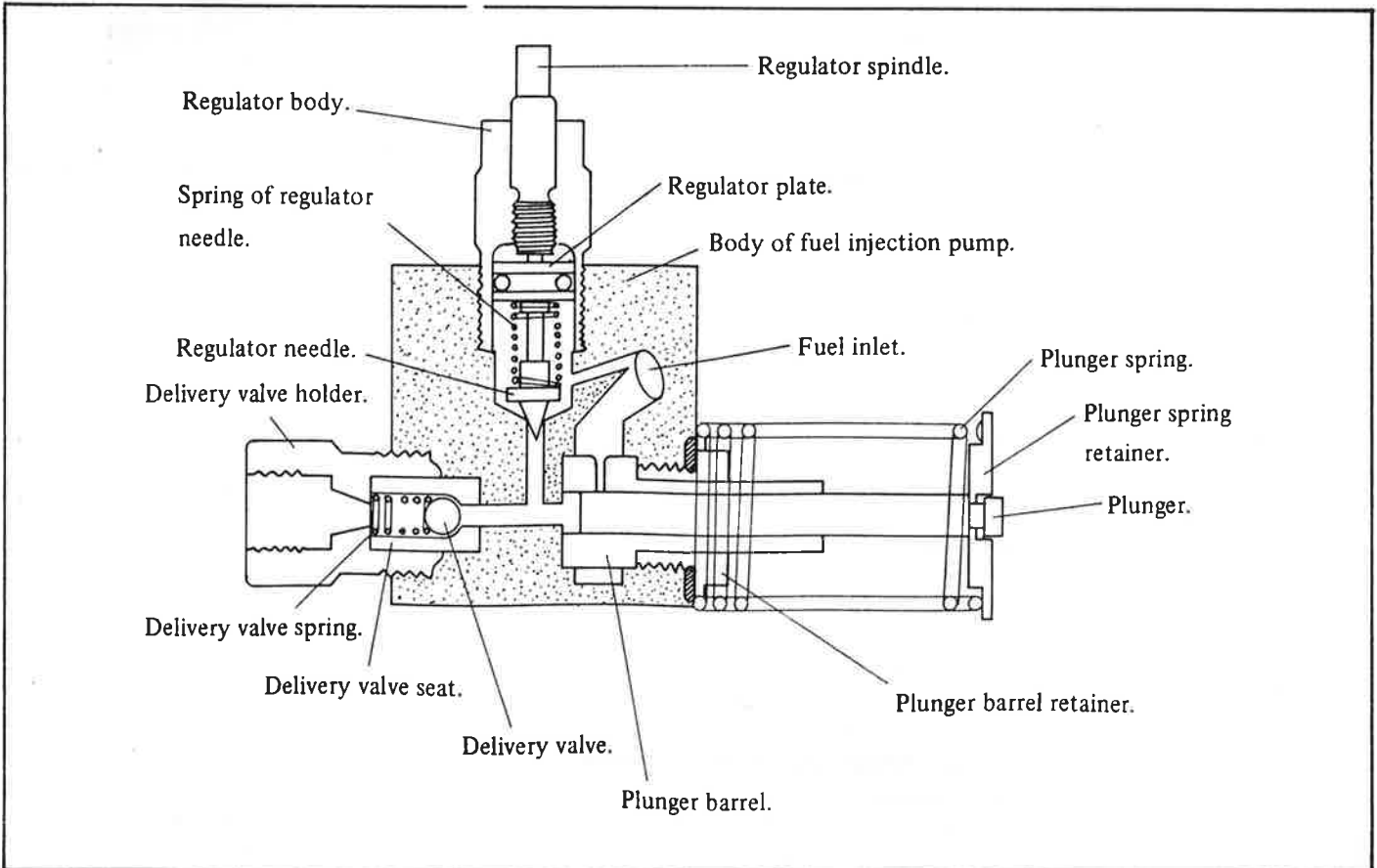

---

### Disassembly:

- Use off-set wrench.
- Remove control lever and protective cover.
- Remove pump assembly from engine block.
- Remove delivery valve holder, delivery valve, delivery valve seat, and delivery valve spring.  
(Check for damage to valve seat or delivery valve.)
- Remove regulator body/spindle assembly.
- Remove regulator needle, spring, regulator plate, and regulator spindle.  
(Check for ease of rotation of regulator spindle. Check regulator needle for wear or damage.)
- Remove plunger, spring, and washer.  
(Check for plunger wear.)
- Remove plunger retainer and take out plunger barrel, copper washer, and gasket.

### Reassembly:

- Use off-set wrench.
- Regardless of condition, the following parts must be replaced each reassembly:
  - Copper washer of plunger barrel.
  - Gasket.
- Insert plunger/plunger barrel assembly in pump body.  
(Fuel intake port of plunger barrel should be horizontal.)
- While moving plunger back and forth to make sure of ease of movement, tighten plunger barrel retainer (7 kg-m torque).
- Insert regulator spindle, regulator plate, spring, and needle in regulator body.
- Mount regulator body/spindle assembly on engine block.  
(Pump body and regulator body should be mounted so that regulator spindle is pointing up vertically to the extent possible. After assembly is completed, check regulator spindle for ease of rotation.)
- Place delivery valve, seat, and spring in delivery valve holder.  
(Be sure that all parts are installed in the correct direction.)
- After assembling, mount on pump body. Take care not to drop delivery valve.

**Note:** If the following parts are replaced, they must be replaced as assemblies.

- Plunger and plunger barrel.
- Delivery valve, delivery valve seat, or delivery valve spring.
- Regulator body, spindle, or plate.
- When parts are being washed in fluids other than diesel oil, such as gasoline, kerosene, etc, it is imperative that the O-ring be removed beforehand.

Deckel type injection pump

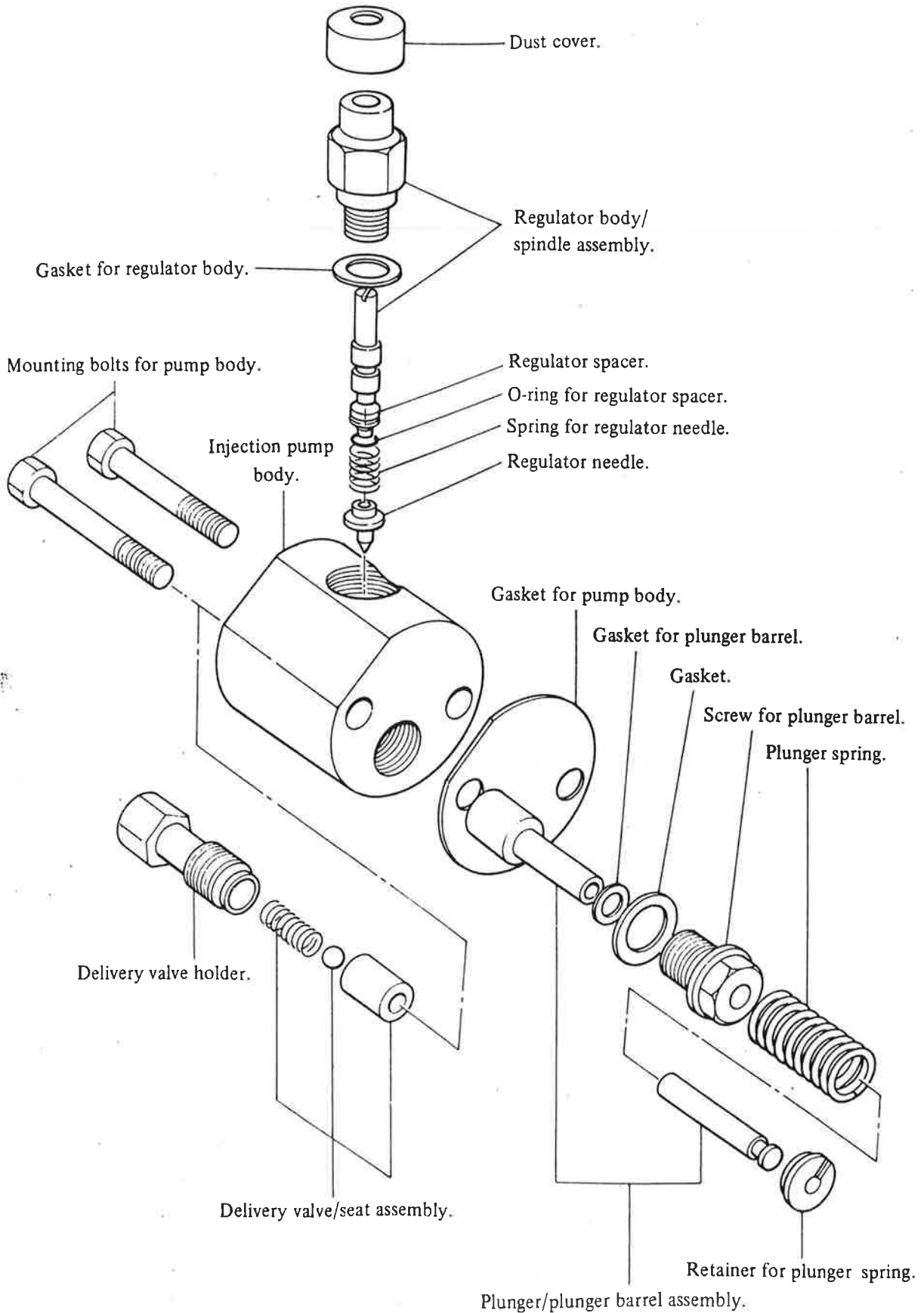

## Fuel injection valve

- Tools and instruments required:

Spanner (17, 24mm), rags, pallet for disassembly, treated oil.

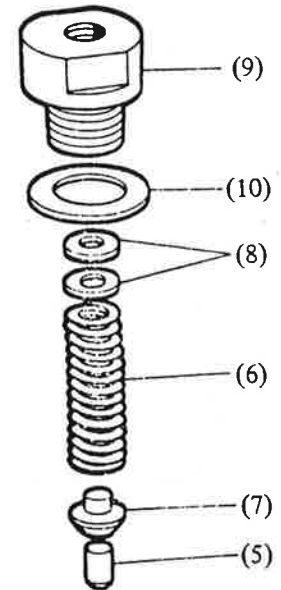
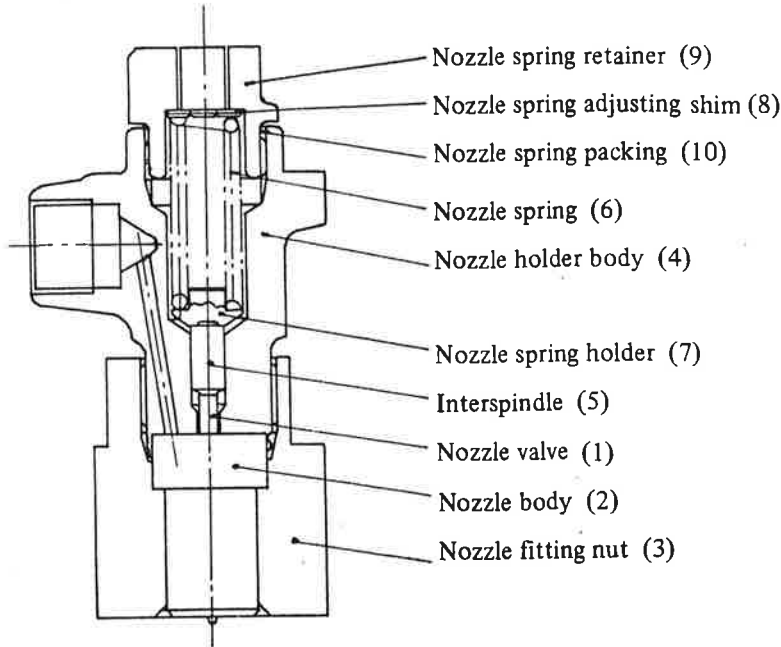

### Disassembly:

- Detach the nozzle spring retainer.
- Take out the nozzle spring adjusting shim, nozzle spring, nozzle spring holder and interspindle. (Be careful not to lose the nozzle spring adjusting shim)
- Unscrew the nozzle fitting nut and remove the nozzle valve body unit.
- Visually check for damage and wear of the nozzle valve.
- In case of replacement, the nozzle valve and nozzle body should be replaced as a set.

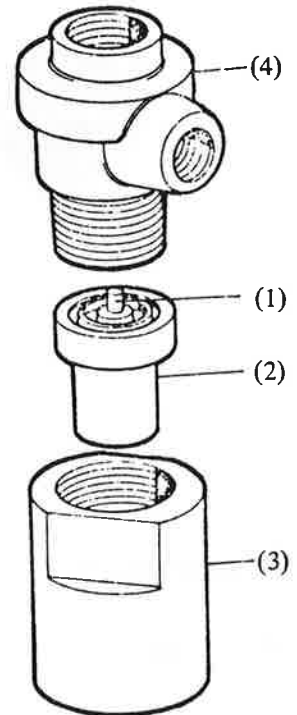

### Assembly:

- Install the nozzle valve and body housings and tighten the nozzle fitting nuts.
- Set the interspindle.
- Set the nozzle spring holder. (Be careful not to put this in upside down)
- Set the nozzle spring. (No difference between upper and lower)
- Place the nozzle spring adjusting shim and fasten the nozzle spring retainer.

**Note:** • After assembly, check the injection pressure and the spray condition with a nozzle tester.

- In case it is difficult to pull out the nozzle body, use a nozzle puller.

---

## Cooling water pump (Refer to section 3-3-10)

### Disassembly:

- Remove cover of cooling water pump.
  - Paper gasket and 6 bolts.
- Remove impeller.
  - Inspect impeller, inner surface of pump body, and inner surface of pump cover for damage or wear.
- Remove circlip 30.
- Striking from the impeller end, pull out the pump shaft.
  - Remove the two bearings and shaft circlip 10.

### Reassembly:

- Follow the above instructions in reverse.

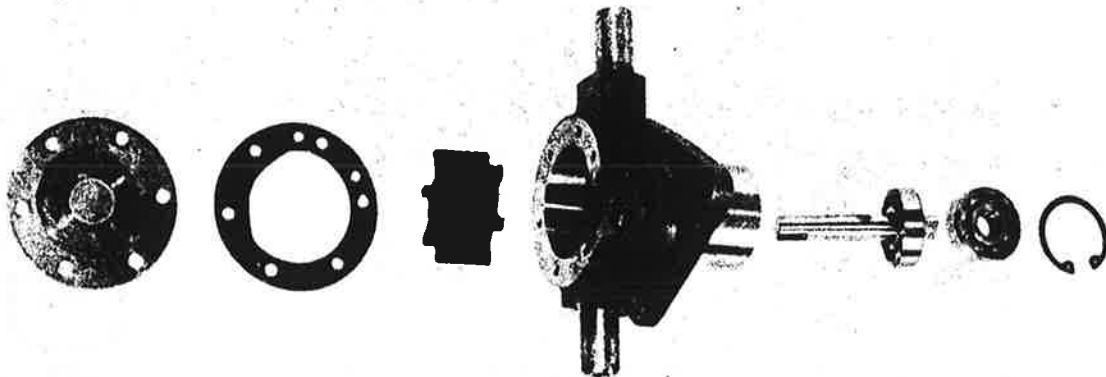

## 4. ADJUSTMENT

### 4-1. Air Bleeding.

- The fuel injection system is composed of the fuel tank, fuel filter, feed pump, injection pump, injection line, and fuel injection valve. If air enters any part of the system, with the exception of the fuel tank, fuel will not be injected into the cylinders.
- If the engine has run out of fuel, or the injection pump has been disassembled and replaced, air will have entered the injection system and should be bled according to the following instructions.

- (1) Open fuel cock of fuel tank and allow fuel to flow into filter. Loosen the air bleeding screw at the top of the fuel filter.

Note: Loosen bleeding screw until bleeding orifice is visible.

- (2) Pump fuel using the feed pump priming lever.
- (3) When the fuel coming from the bleeding screw of the fuel filter is free of bubbles, tighten the bleeding screw firmly.

- (4) Disconnect fuel injection line.

- (5) Remove delivery valve holder. Pump fuel using feed pump priming handle.

- (6) When the fuel which flows out is free of bubbles, replace delivery valve holder, tightening firmly. Replace injection line.

Note: The connection of the injection line at the injection valve end is left loosened for the time being.

- (7) Set speed control lever in starting position and place decompression lever in position of no compression.

- (8) Using either the starter motor or hand crank, turn the engine over until the fuel flowing from the injection valve/pipe connection is free of bubbles. At this point tighten the connection firmly.

Note: As the individual case may dictate, steps 4, 5, and 6 may be omitted.

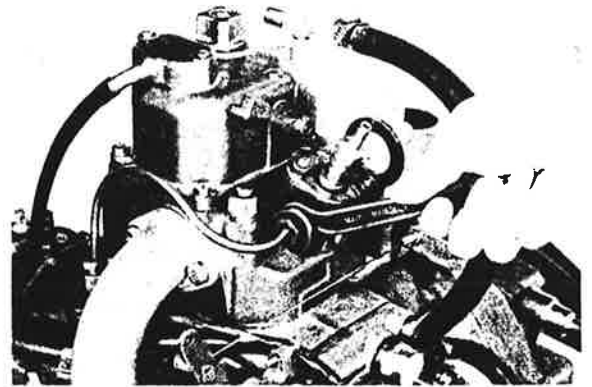

#### 4-2. Fuel Injection Pump

Fuel injection timing should be checked and adjusted. As fuel injection takes place  $8^{\circ} \sim 12^{\circ}$  before T.D.C., testing should be carried out according to the following instructions.

- (1) Remove starter motor from rear of clutch case. If the engine is a crank-start model, remove the cover over the starter motor hole.
- (2) Place speed control lever in high speed position.
- (3) Remove fuel injection line.
- (4) Actuating the decompression lever, turn the engine over until fuel is seen flowing from delivery valve.



(5) Using the starting crank, or other means, slowly turn the flywheel until the point at which fuel begins to flow from delivery valve; stop the flywheel at this point.

(6) Observe the timing mark on the crankcase and the scale on the flywheel; note the position on the scale.

Note: This procedure should be carried out a number of times and an average value taken.

If timing is too early or too late, adjust by adding or reducing timing adjustment shims between pump mount and cylinder block. At adjustment shim of 0.2 mm thickness will change timing by approximately  $2^\circ$ , a shim of 0.3 mm thickness approximately  $3^\circ$ . If timing is early, adjustment shims are added, if late, shims reduced.

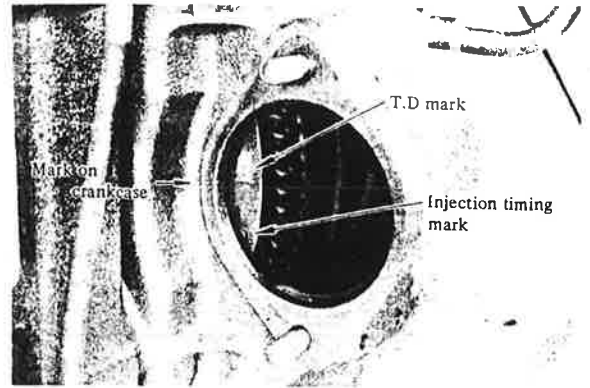

### 4-3 Fuel Injection Valve

Measurement and regulation of nozzle injection pressure.

- Connect the fuel injection valve to the injection pipe of the nozzle tester and tighten carefully.
- Operate the lever of the nozzle tester slowly and read the pressure the moment when the fuel begins to eject from the nozzle.
- In case the injection pressure is lower than the rating, detach the nozzle spring holder and add the injection pressure adjusting shim.

- Rated injection pressure  $160 \pm 5 \text{ kg./cm}^2$
- Kinds of injection pressure adjusting shims (thickness):
 

(with a plate of 0.1 mm thick,	0.1 mm
a change of approximately 0.5	0.2 mm
kg/cm <sup>2</sup> can be obtained.)	0.3 mm
	0.5 mm

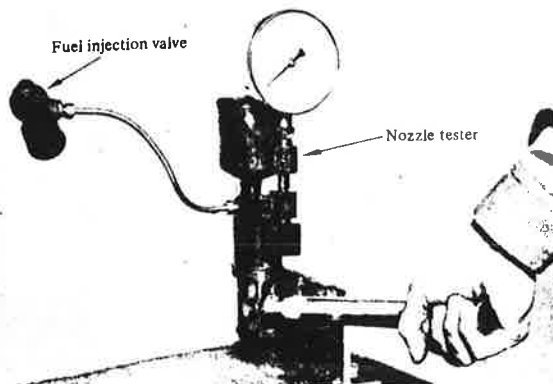

### Check of spray condition

- Observe the spray condition by operating the lever of the nozzle tester 4 ~ 6 times/sec., after regulating the injection pressure of the nozzle to 160 kg/cm<sup>2</sup>. In case of abnormality, clean or replace the nozzle.

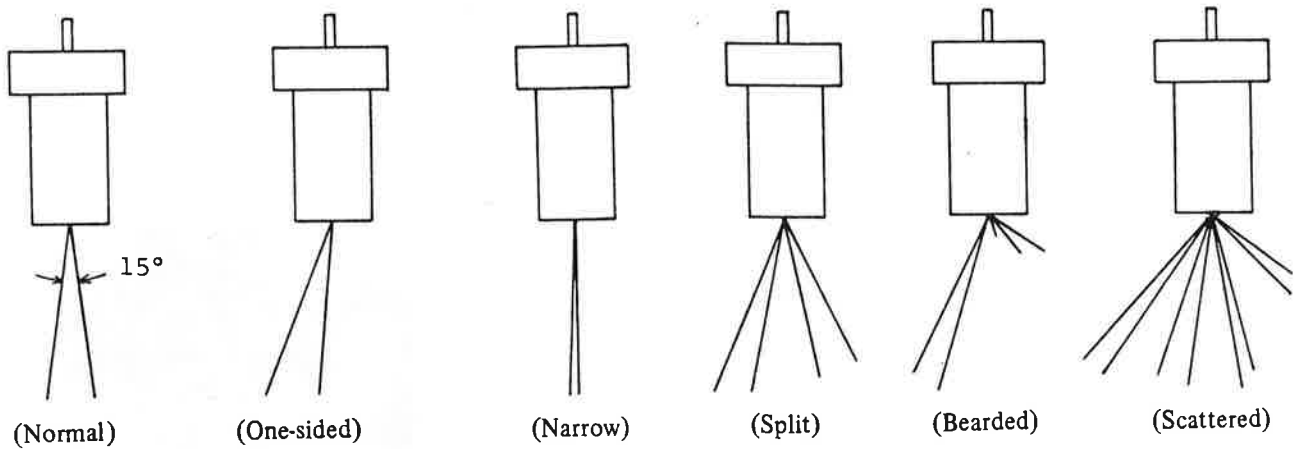

- Inject the fuel several times by operating the lever of the nozzle tester and then wipe off the oil from the nozzle part. Further, raise the hydraulic pressure to 140 kg/cm<sup>2</sup> (which is lower than the fuel injection pressure by 20 kg/cm<sup>2</sup>) if oil drops from the nozzle, the device is defective.

### 4-4. Adjustment of rocker arm intake/exhaust valve clearances (cold).

1. Remove rocker arm cover.
2. Align T.D.C. mark of flywheel with datum mark on crankcase.  
Note: Piston should be in compression stroke.
3. Loosen locknut of adjustment screw. Measure valve clearance with thickness gauge and adjust to 0.2 mm.
4. Tighten locknut firmly.

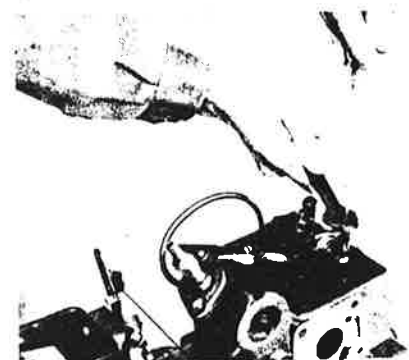
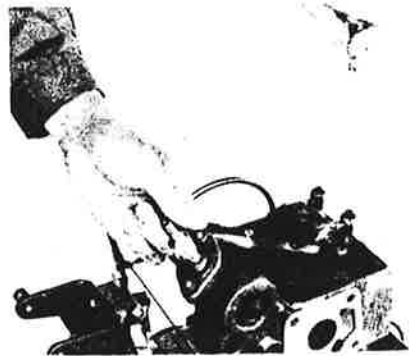
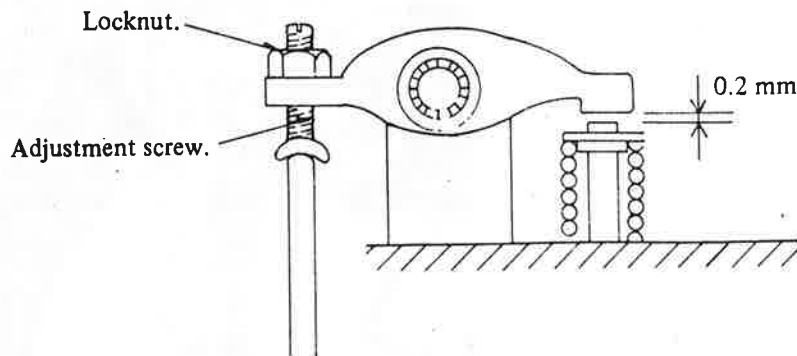

#### 4-5 Adjustment of Governor Linkage.

The governor and governor linkage function much as the human brain does, monitoring the changes in engine load and transmitting the corresponding changes in fuel injection volume to the injection pump. To keep the engine running in top condition, the governor linkage should be kept in proper adjustment according to the following instructions.

- Loosen the locknut of the connecting screw, and the screws of the pump adjustment lever.
1. Place speed control lever in running position.
  2. Make the slot at the upper end of the connecting screw parallel with the pump adjustment lever. The punch mark should face the cylinder block.

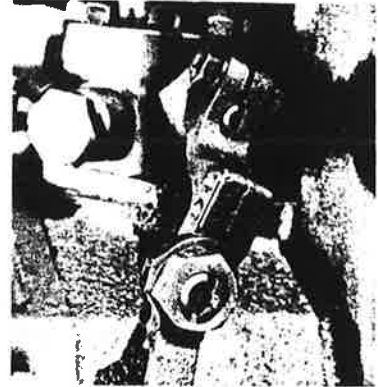

3. With light pressure turn the regulator spindle to the completely closed position



4. Tighten the pump regulator lever fastening screw.

Note: Tighten without moving the pump regulator lever.

After tightening the screw, tighten locknut.



5. Rotate the connecting screw 90° counterclockwise.

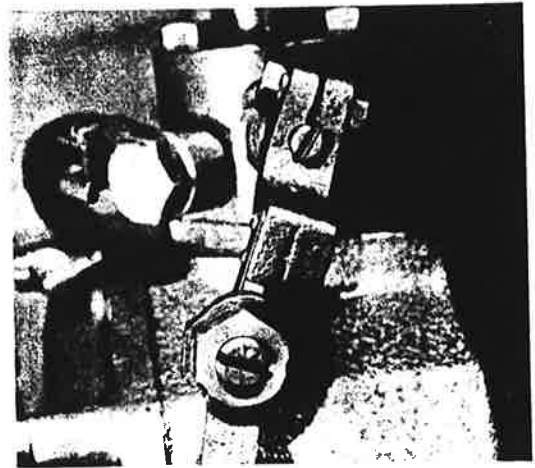
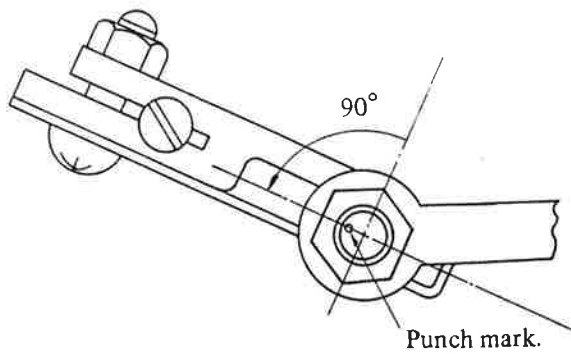

6. Holding the connecting screw in this position, tighten the locknut.



Note: After adjustment, perform the following:

1. Place speed control lever in the running position.
2. Actuating the decompression lever, turn the engine over and listen for the sound of injection.
3. Place the speed control lever in the stop position; using the hand, push governor lever toward engine block.
4. Turning the engine over as described in item 2, confirm that injection is not taking place.

If the engine does inject at this point, it is likely to overrev when running.



## 2. Operation

Fig. 1 gives a schematic layout of the starter motor electrical circuit. The current flow of the circuit is as follows:

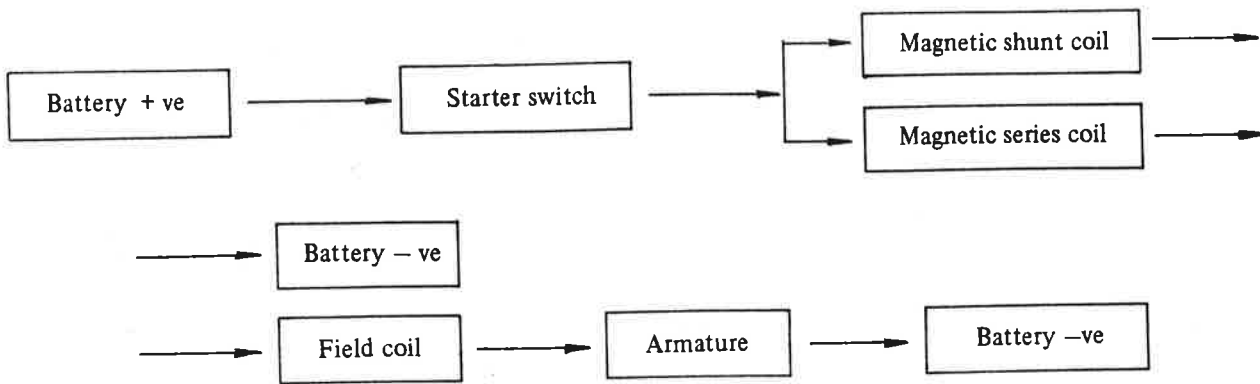

## 3. Inspection

When the starter motor is considered to have faults, it should be dismantled for detailed inspection.

### (1) Armature

Coil and commutator inspection:

Rare short test ..... existence of coil broken or disconnecting.

Fig. 2: Checking commutator for insulation defects.

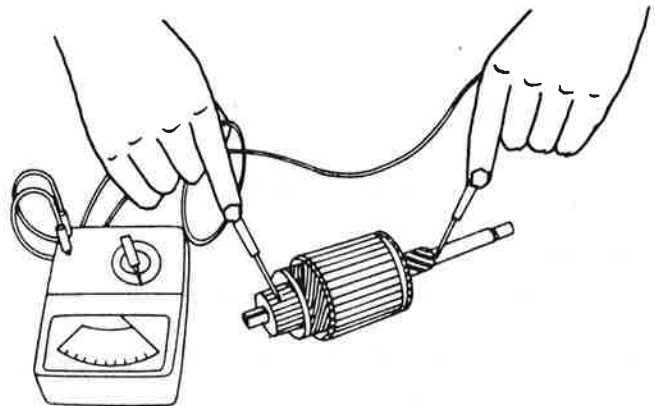

Insulation test ..... Between commutator and armature core or distortion shaft.  
(See Fig. 2 & 3)

Fig. 3: Checking armature windings for insulation faults.

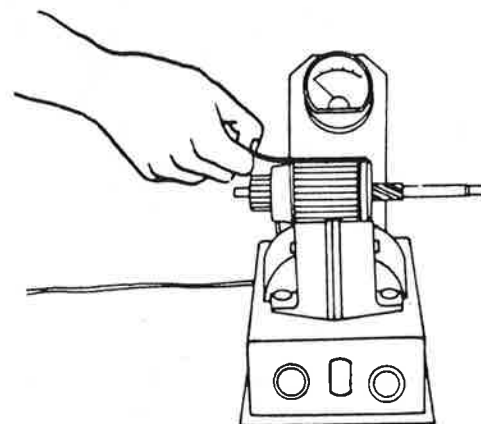

(2) Commutator

a) Commutator surface inspection.

If the surface is not clean, polish it lightly with very fine glass paper. (See Fig. 4)

b) Commutator segments depth measurement.

If the commutator is badly worn, take a light cut on the lathe with a sharp tool. After under cutting, it should be polished with very fine glass paper. (See Fig. 5)

Fig. 4: Polishing commutator with fine glass paper.

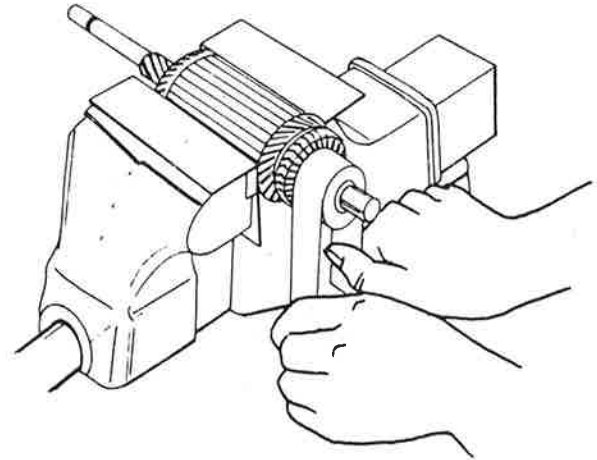
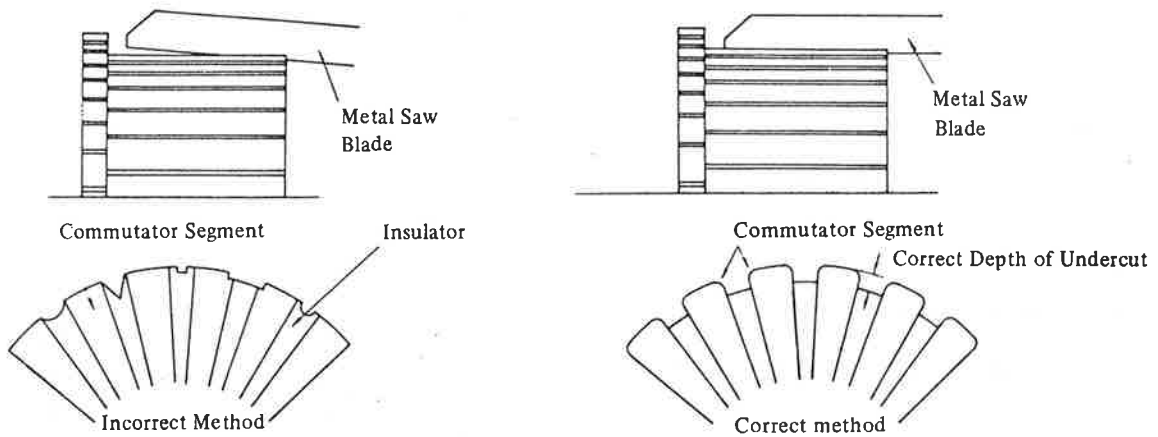

Fig. 5: Wrong and right method for under-cutting insulators on commutator.



(3) Field coil

a) Insulation test. (See Fig. 6 & 7)

Fig. 6: Checking field coils for open circuit defects.

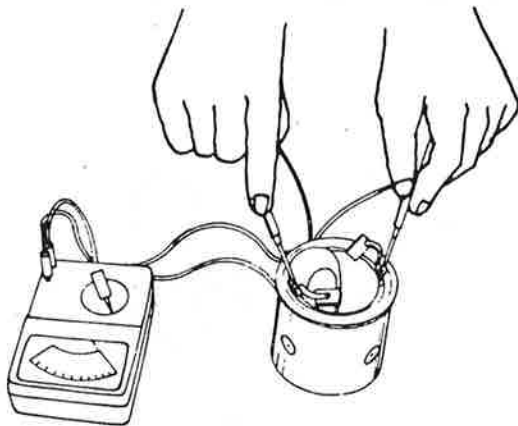
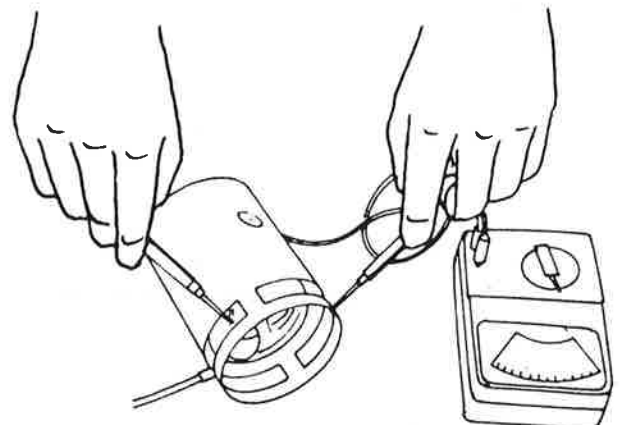

Fig. 7: Checking field coils for insulation defects.



(4) Magnetic switch

a) Conductivity test ..... hold-on windings (Shunt coil). (See Fig. 8)  
No reading indicates an open circuit in hold-on windings.

operating windings (Series coil). (See Fig. 9)  
No reading indicates an open circuit in operating windings.

Fig. 8: Checking solenoid hold on windings.

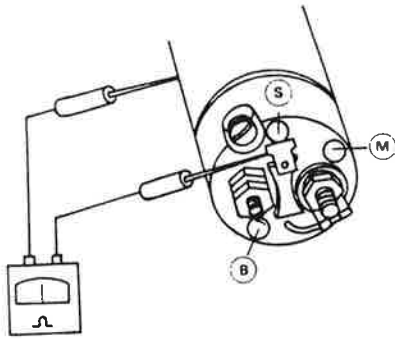
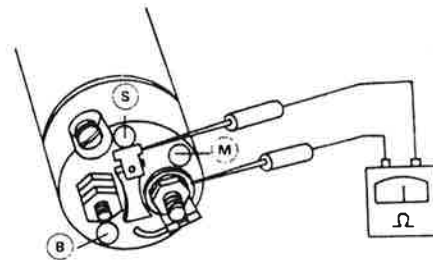

Fig. 9: Checking solenoid operating windings.



(5) **Brushes**

Brushes worn in excess of the values should be renewed. When fitting a new brush ensure it is properly bedded to the commutator face and is free in its holder.

4. **Adjustment and performance test**

(1) **L-size measurement (Gap between pinion and pinion stopper) (See Fig. 10)**

When the pinion is at the projected position, measure between pinion and pinion stopper. This check should be made with the pinion pressed back lightly to take up any play in the engagement linkage.

(2) **Pinion movement**

After complete assembly of the starter motor, connect up the motor as in Fig. 11.

Fig. 10: Checking gap between pinion and pinion stopper (L-size)

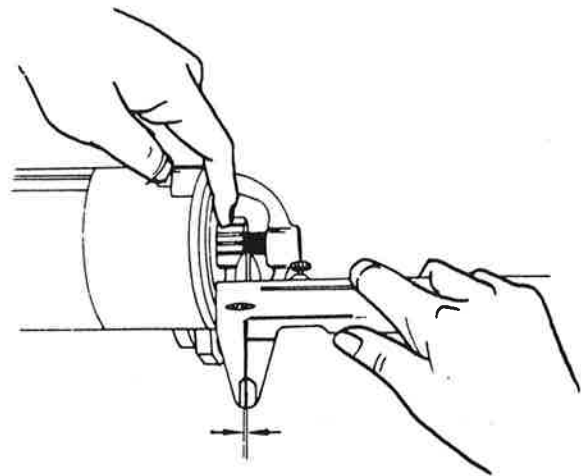
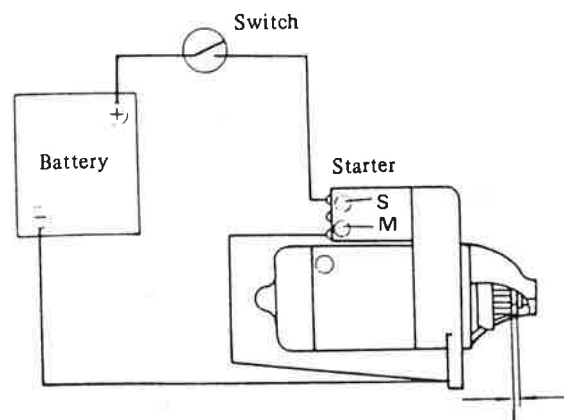

Fig. 11: Testing circuit for pinion movement.



(3) Plunger movement

Adjustment made by adjusting stroke of magnetic plunger to the prescribed value.

Fig. 12: Adjustment for plunger movement (Shim adjusting type)

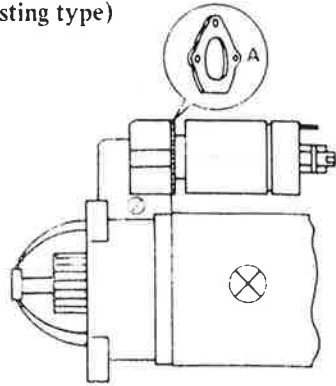
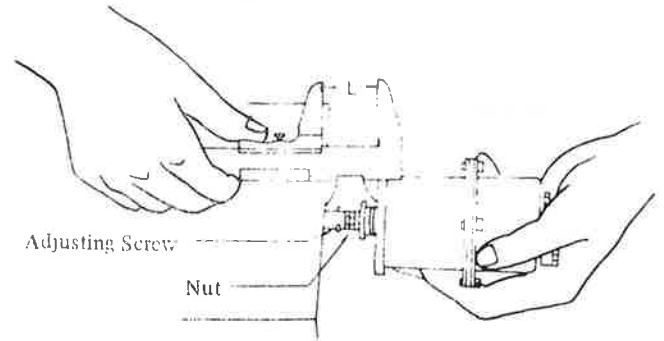
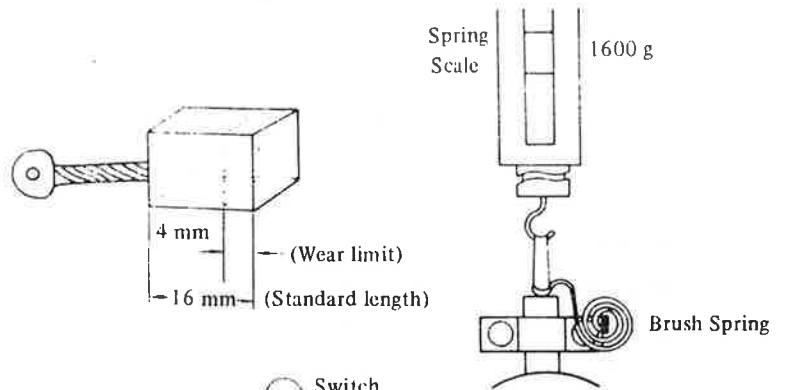

Fig. 13: Adjustment for plunger movement (Adjusting screw type)



(4) Brush spring pressure

Fig. 14: Checking brush spring strength.



(5) Light running current test

Fig. 15: Measuring the light running current.

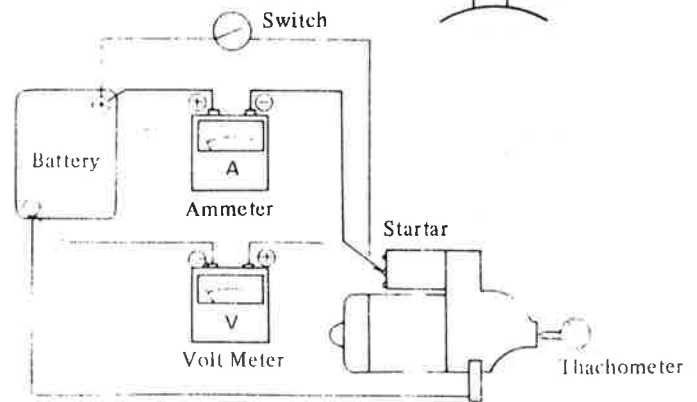

(6) Pinion lock torque measurement

Fig. 16: Measuring lock torque:

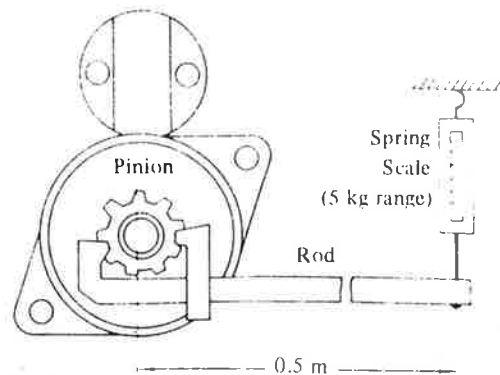

(7) Mesh clearance

Mesh clearance is the distance between the flywheel ring gear and starter motor pinion in the rest position. This clearance should be between 3 mm to 5 mm.

Fig. 17: Checking mesh clearance.

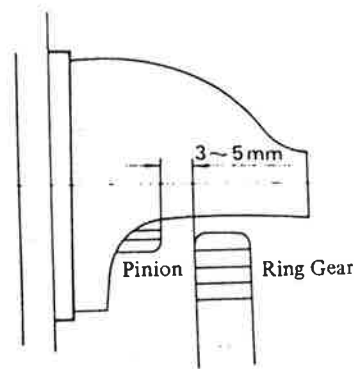

5. Specifications and servicing standard values (For model SVE)

Specifications

Model		S111-194
Rating	(Sec)	30
Norminal output	(KW)	1.0
Direction of rotation (Viewed from pinion side)		Clock wise
Weight	(Kg)	49
Clutch system		Overrunning
No load	Terminal voltage (V)	12
	Curent (A)	60 or less
	Rev. speed (rpm)	7000 or less
Con- strac- tion	Terminal voltage (V)	6
	Current (A)	380 or less
	Torque (Kg.m)	0.8 or above
Max. clutch coupling capacity Kg.m		—
Pinion protruding voltage (V)		8 or less
Engaging system		Magnetic shifting

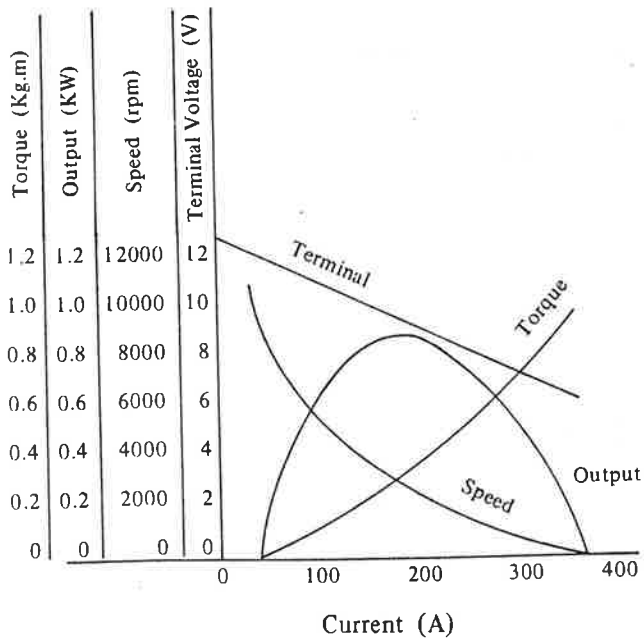

Major data

Pinion	Module	10/12
	Number of Teeth	9
	Pressure angle (degree)	20
	Outer diameter (mm)	29.6
	Pitch diameter (mm)	22.86
	Amount of addendum modification (mm)	1.27
	Hardness (HR C)	58 ~ 63
Yoke outside diameter		80
Armature outside diameter		52.7
Number of poles		4
Magnetic switch	Series coil resistance	0.324 at 20°C
	Shunt coil resistance	0.694 at 20°C

Adjustment specification

(unit: mm)

Brush		Standard height	16
		Minimum limit	4
Brush spring (Kg)		Standard pressure	1.6
Commutator	Outer diameter	Standard O. D.	33
		Minimum limit	2
	Difference between maximum and minimum diameters	Limit of correction	0.4
		Accuracy of correction	0.05
	Depth of mica	Limit of correction	0.2
		Accuracy of correction	0.05 ~ 0.08
Gap bet. shaft and bearing. ( ): intermediate brg.		Limit of correction	0.2
		Accuracy of correction	0.03 ~ 0.1
Wearing limit of shaft diameter			0.1
Corrective limit of shaft bending			0.08

Adjustment specification

(unit: mm)

Standard dimensions	Brush side bearing	Shaft dia	12.5	-0.032 -0.050	Pinion side bearing	Shaft dia.	12.5	-0.032 -0.050
		Bore	12.5	+0.027 0		Bore	12.5	-0.027 0
	Intermediate bearing	Shaft dia.	17.45	±0.02	Magnetic switch contactor gap		3	
		Bore	17.6	+0.025 0	Gap bet. pinion and ring gear		3 ~ 5	
		Shaft dia.	12.5	-0.027 0	Gap bet. pinion and pinion stopper when plunger gas is zero.		0.3 ~ 1.5	
		Bore	12.5	+0.050 +0.030				

(3) Lubrication chart

- i) Ensure that the parts indicated in Fig. 18 are lubricated with "Shell Alvania Grease No. 2" or good quality high melting point equivalent grease.
- ii) Be sure to insert the thrust washer between the commutator end bracket and the armature. If the end float is more than 0.3mm a further shim should be added.

Fig. 18: Lubrication chart.

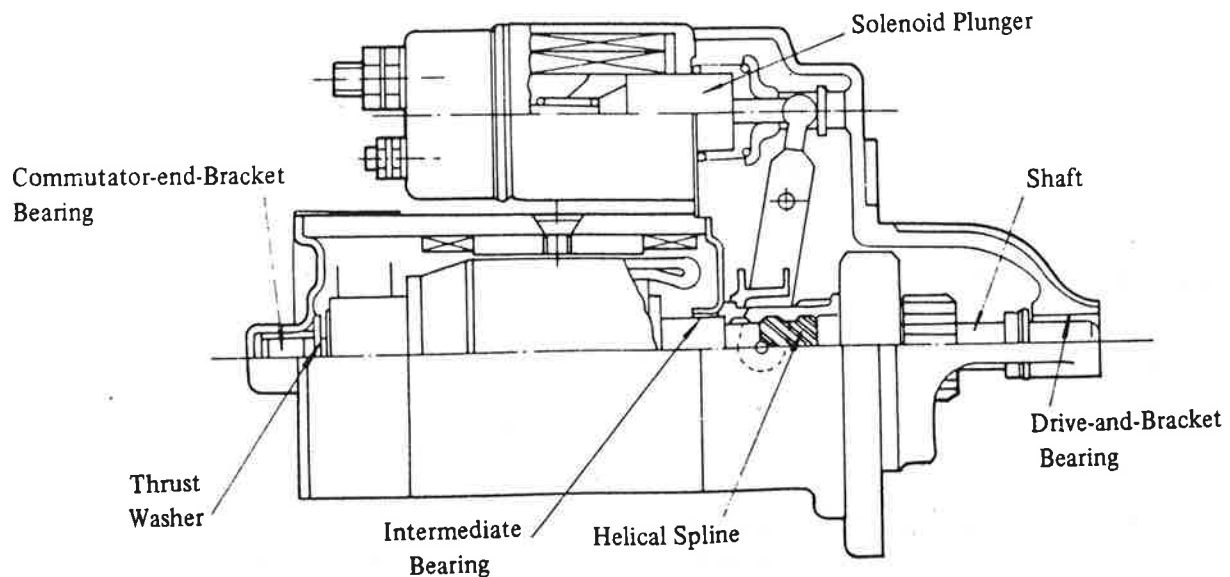

---

## 6. Malfunction and trouble shooting

- (1) Pinion doesn't extend when switch is on.
  - Loose wiring.
  - Switch contacts bad.
  - Magnetic engagement lever malfunctioning.
- (2) Pinion extends but motor doesn't turn.
  - Disconnected or grounded between battery and magnetic switch wires.
  - Improper mesh between pinion and ring gear.
  - Poor contact between brushes and commutator.
  - Bad contact in magnetic switch.
- (3) Motor turns before pinion meshes with ring gear.
  - Plunger gap mis-adjusted.
  - Weaken plunger spring.
- (4) Pinion engages and motor rotates, but drive force is not enough.
  - Over-speed clutch is bad.
- (5) Engine doesn't stop when switch is turned off.
  - Main switch is bad.
  - Magnetic switch contacts stuck in closed position.
  - Return spring weak or broken
- (6) Speed torque and current consumption is low.
  - Faulty internal or external connections.
  - Dirty or burned commutator.
  - Burned magnetic switch contacts.
- (7) Speed and torque is low but current consumption is high.
  - Broken bearing.
  - Bent shaft.
  - Armature fouling pole shoes.
  - Cracked spigot on drive end bracket.
  - Short-circuited or grounded armature.
- (8) Speed and current consumption is high but torque is low.
  - Short-circuited windings in the field coil.
- (9) Excessive arcing at the commutator.
  - Defective armature windings.
  - Sticking brushes or dirty commutator.

## 5-2. A.C. GENERATOR

### 1. Composition

The generator described on this chapter is three phase revolving field type generator.

This AG generator rectifies the alternating current and supplies direct current (DC) to an external source.

The generator is composed of three major parts:

Rotor which incorporates the field winding, Stator which has electricity generated in it, and Diodes which rectify the alternating current generated in the stator coils.

The drive is done by pulley with cooling fan.

Fig. 19: Principle of AC generator.

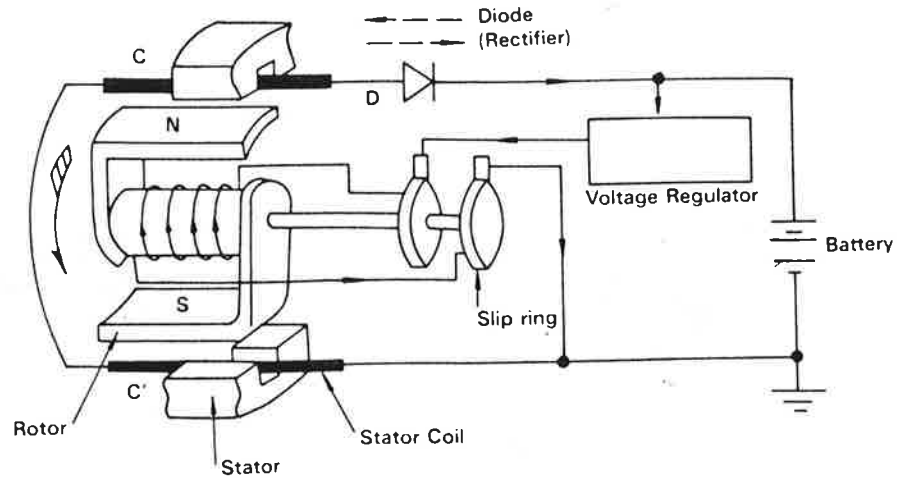

## 2. Operation

When DC is supplied to the rotor coil through the slip rings the rotor becomes magnetized, with magnetic flux lines forming between the N-S poles. Rotation of the rotor generates an alternating current in the stator coil, which is then rectified by the diodes as a DC charging current for the battery.

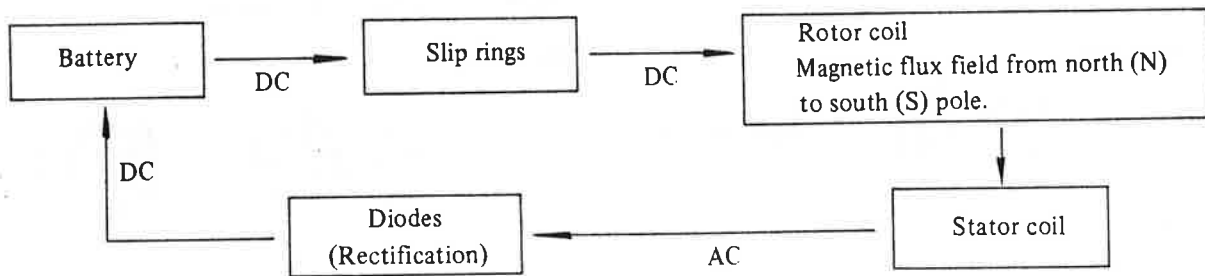

## 3. Inspection

### (1) Rotor

Conductivity test ..... Between slip rings.

Insulation test ..... Between slip ring and rotor coil.

Fig. 20: Testing rotor coil conductivity.

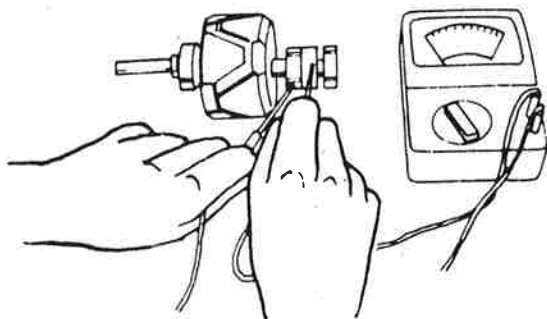
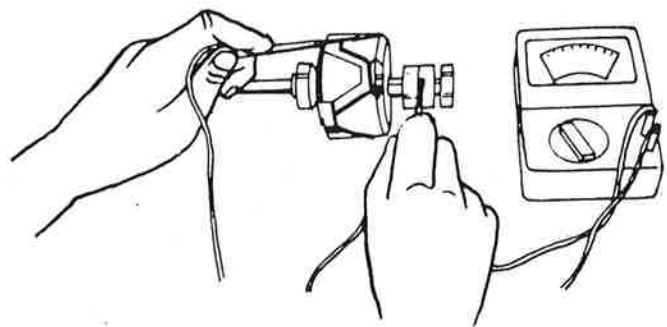

Fig. 21: Testing rotor coil insulation.



(2) Stator

Conductivity test . . . . . Between stator coil terminals.

Insulation test . . . . . Between stator coil terminals and stator core.

Fig. 22: Testing stator coil conductivity.

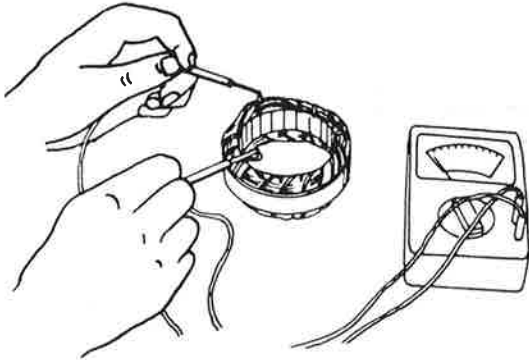
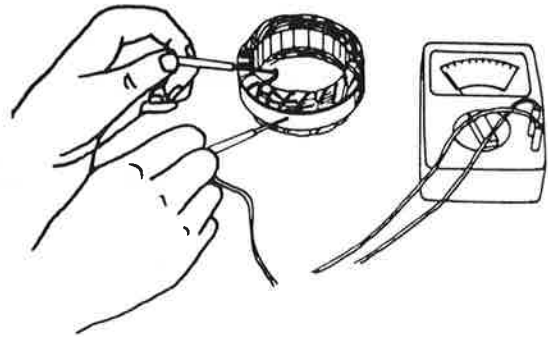

Fig. 23: Testing stator coil insulation.



(3) Diode

Conductivity test . . . . . Between diode terminals and its case.

Fig.24: Testing diode conductivity.

Black mark

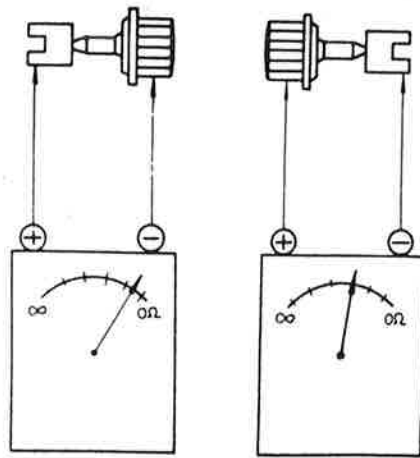

The meter should read. The meter should not read.

Red mark

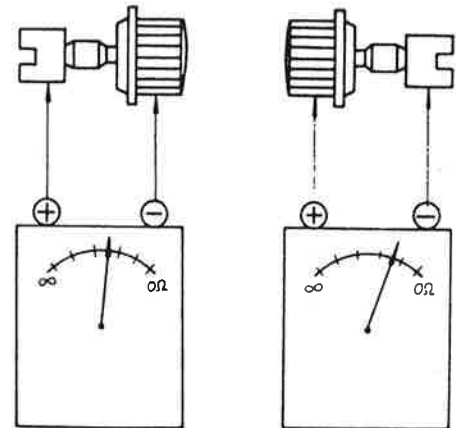

The meter should not read. The meter should read.

To test the diodes, first check the polarity.

- a) Black marked on the case . . . . . Negative base diodes.
- b) Red marked on the case . . . . . Positive base diodes.

Fig. 25-1: Conductive direction of diode.

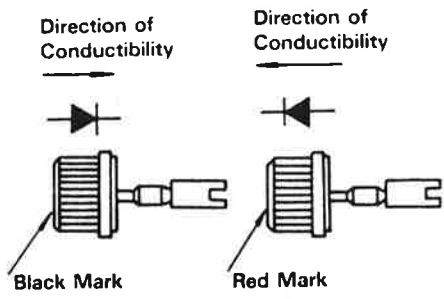

Fig. 25-2: Disconnecting diode.

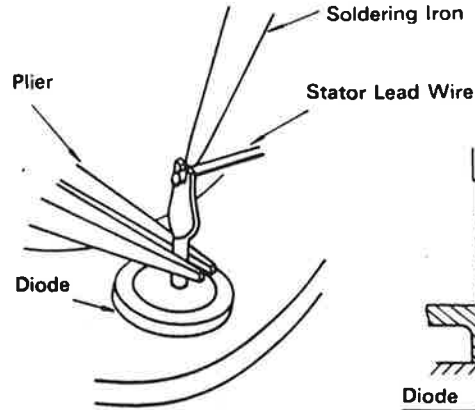
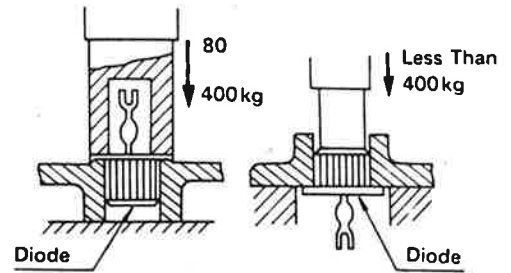

Fig. 25-3: Replacement of diode.



(4) Brushes

Brush spring pressure and brush length .....

Fig. 26: Checking brush spring strength.

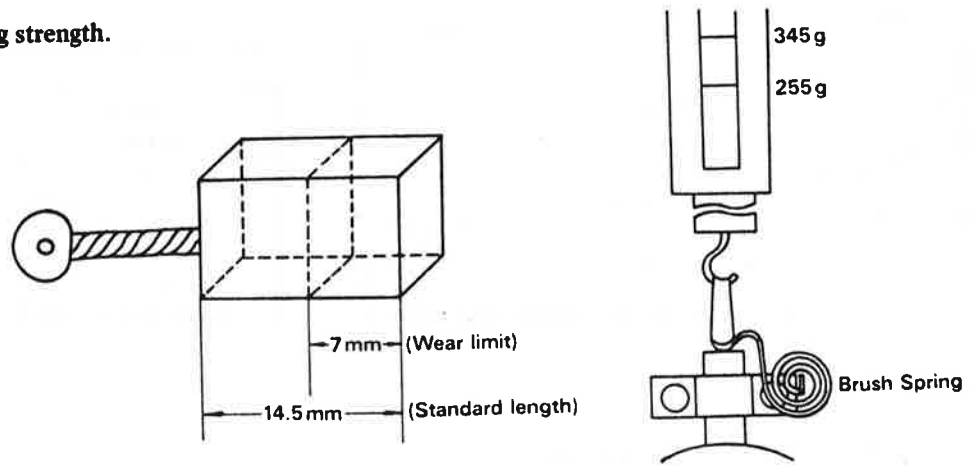

## 4. Specifications and servicing standard values

### Specification

Model	Generator	LR135-31
	Regulator	TR1Z-28
Rating	Continuous	
Battery voltage (V)	12	
Nominal output	12V 35A	
Rated speed (rpm)	5000	
Maximum operational speed (rpm)	6500	
Direction of rotation (viewed from pulley side)	clockwise or counter clockwise, applicable for both directions	
Voltage regulation (V)	14.3 ± 0.3 V at 25°C	
Standard temperature gradient (V/°C)	-0.0136	
Output current (A/V/rpm)	32/13/5000	
Rev. speed at 13V (rpm)	1000 or less	
Earth polarity	2 wire system	
Weight (Kg)	Generator	4.0
	Regulator	-

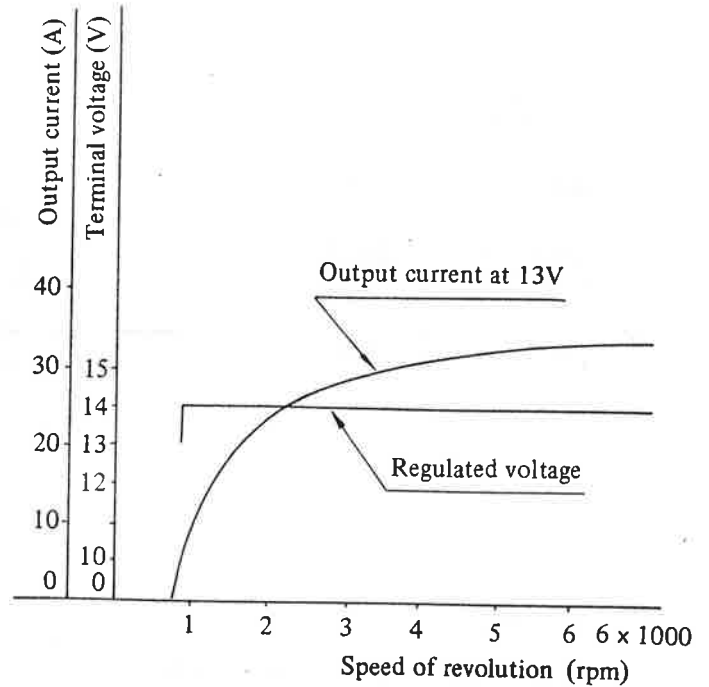

### Major data Generator

	Stator	114
	Rotor	83.2
Resistance (Ω) at 20°C	Stator coil (single phase)	0.128
	Rotor coil	3.3
Number of poles		8
Slip ring (mm)	Standard outer dia./Min. limit	31/30
	Limit of correction/accuracy of correction	0.3/0.05
Pulley	Type of belt/Pulley outer dia.	A type/70
	Ratio	1 step/19

### Adjustment specification Generator

		(unit: mm)	
Strength of brush spring (g)		300 ± 1.5%	
Brush	Standard height	14.5	
	Minimum limit	7	
Shaft	Front side	Standard dimension	15
		Ball bearing	6302 B
	Rear side	Standard dimension	12
		Ball bearing	6201 S-D

## 5. Malfunction and trouble shooting

### (1) No generator output

- Coil (s), ground disconnected; system shorted.
- Non-insulated terminals.
- Diode (s) bad.

### (2) Low output

- Rare short in rotor coil.
- Rare short in stator coil.
- One-phase disconnected from stator coil.
- Slip ring dirty or broken.
- Poor contact between brushes and slip rings.
- Diode (s) bad.
- Low rpm.

### (3) High output

- Short circuited between A and F terminals, the generator may be shunting generator.

### (4) Fluctuating output

- Loose wiring.
- First stage disconnected.
- First interphase stage shorted.
- Brush springs broken or stuck.

### 5-3. Reference Data (for diodes)

Recently semiconductors are being used quite frequently in regulators and AC generators. Therefore a short description on semiconductors in order.

#### 1. Diodes

A diode does not pass current in a reverse direction, only in the forward direction. This rather simple characteristic gives the diode its rectification power.

However, if a high inverse voltage is applied, the diode will break down, permitting a sudden surge of current in the circuit.

Current flow direction is indicated by a mark on the diode.

Fig; 35: Explanation of diode.

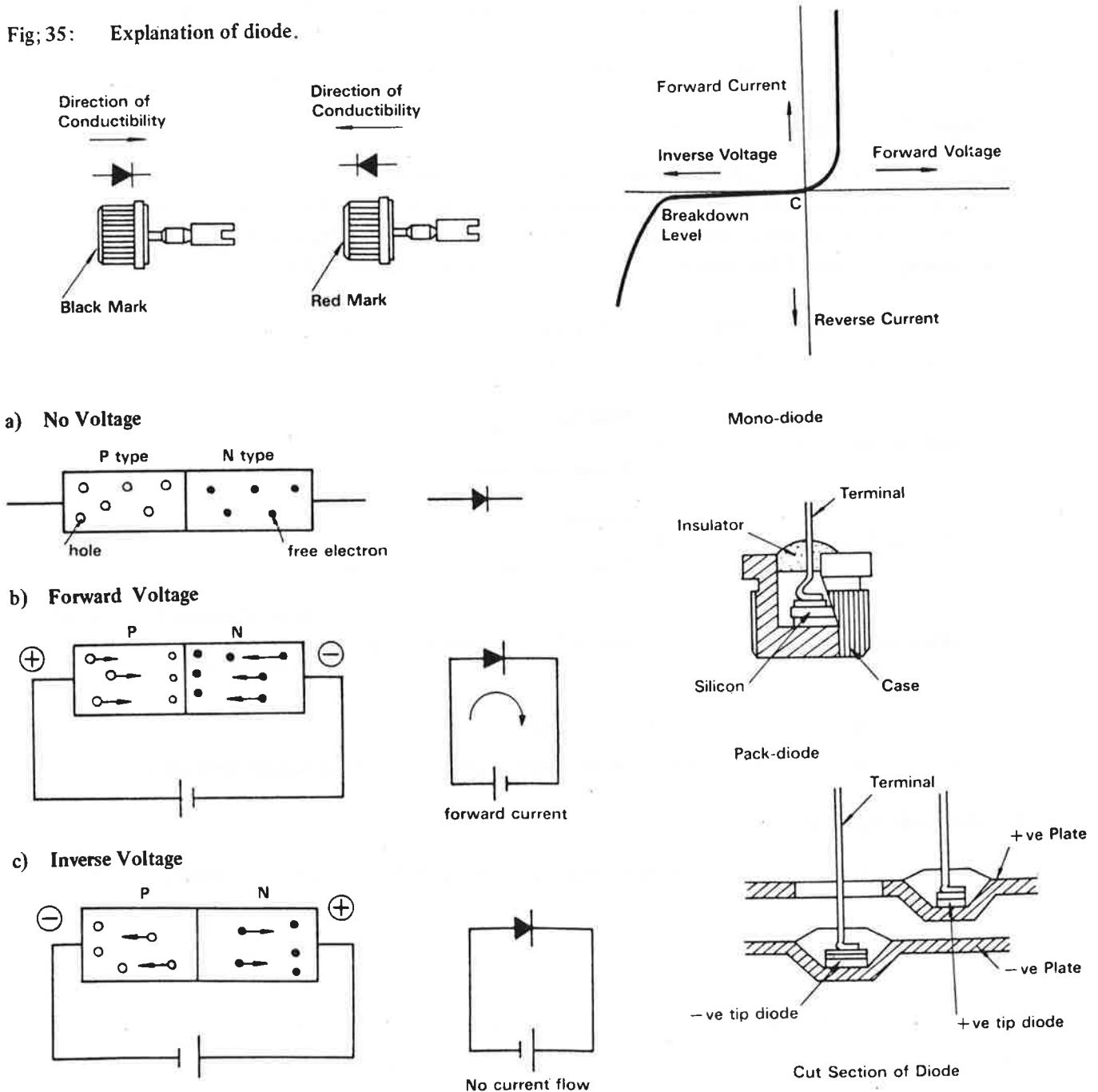

---

## 6. TROUBLE AND COUNTERMEASURES

Malfunctioning engine may be restored to its proper performance by detecting the cause and eliminating that cause with necessary countermeasure. Therefore, it is imperative to know what is the cause of trouble.

For this purpose, it is necessary to obtain the information on engine performance immediately prior to the occurrence of trouble, on condition at the time of trouble, and engine handling situation before any repair or service may be begun.

Consider which part is improper in what manner, why the trouble is resulted and how the trouble may be repaired or serviced before proceeding to actual repairing or servicing.

Furthermore, if the cause of trouble is due to carelessness of engine operator, it is recommended to instruct him the proper handling so that the same trouble will not be resulted again in future. This too, is a duty of the serviceman.

In this section, we will explain on major engine trouble, what is the cause and how the trouble may be treated.

### 6-1. Major Classification of Troubles

If the engine troubles are classified into large groups, they are as follows:

In determining what is cause of trouble, first evaluate the sign of trouble related to the cause and then analyze such sign for pinpointing the major cause of the trouble. If detecting the sign of trouble and its analyzing are finished, determining the cause of trouble and repairing will be facilitated.

1. Difficult starting – The engine is difficult to start or does not start at all.
2. Disordered running – The engine is running but disorderly.

Bad colored exhaust .....	}	Black smoke	
		Blueish-white smoke	
Poor revolution .....	}	Hunting	
		Momentary high-speed revolution	
Abnormal noise .....	Noise other than exhaust sound	}	Noise of suction & exhaust valves
			Noise due to looseness of engine parts

3. Sudden stop – The engine stops running suddenly.
4. Oil, water or gas leakage – The engine works properly but oil, water or gas leakage takes place.

### 6-2. Difficult Starting

When the starting is difficult, the following troubles may be considered. Systematically determine the causes.

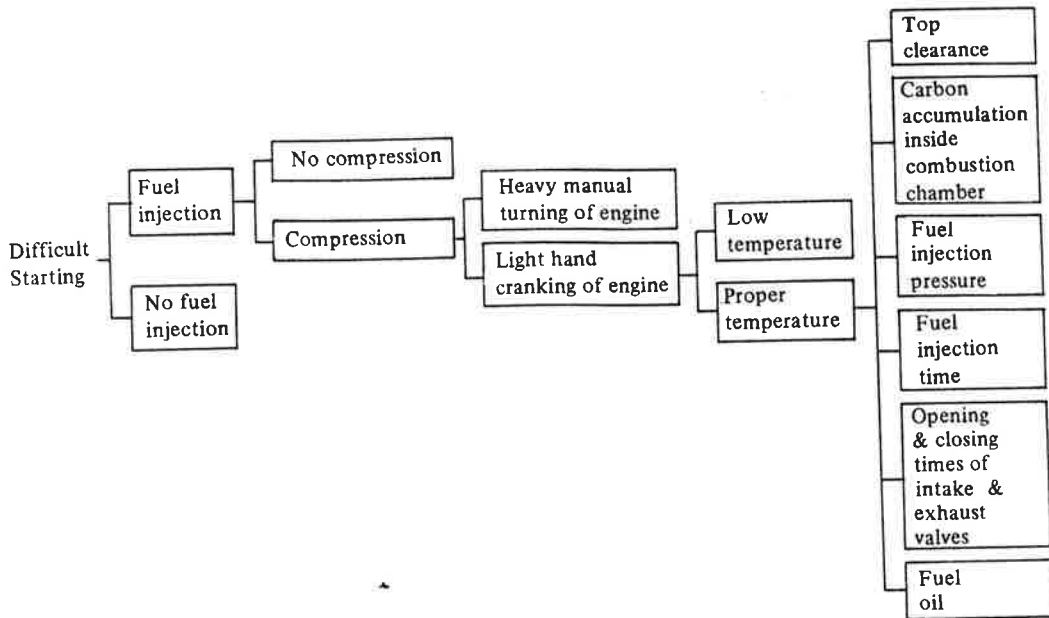

### 6-2-1. No Fuel Injection

If the fuel is injecting from the fuel injection valve under normal condition, the injection sound may be heard. However, when the injection noise is not heard, there is an abnormality in fuel injection system. In such case, systematically determine its causes as follows:

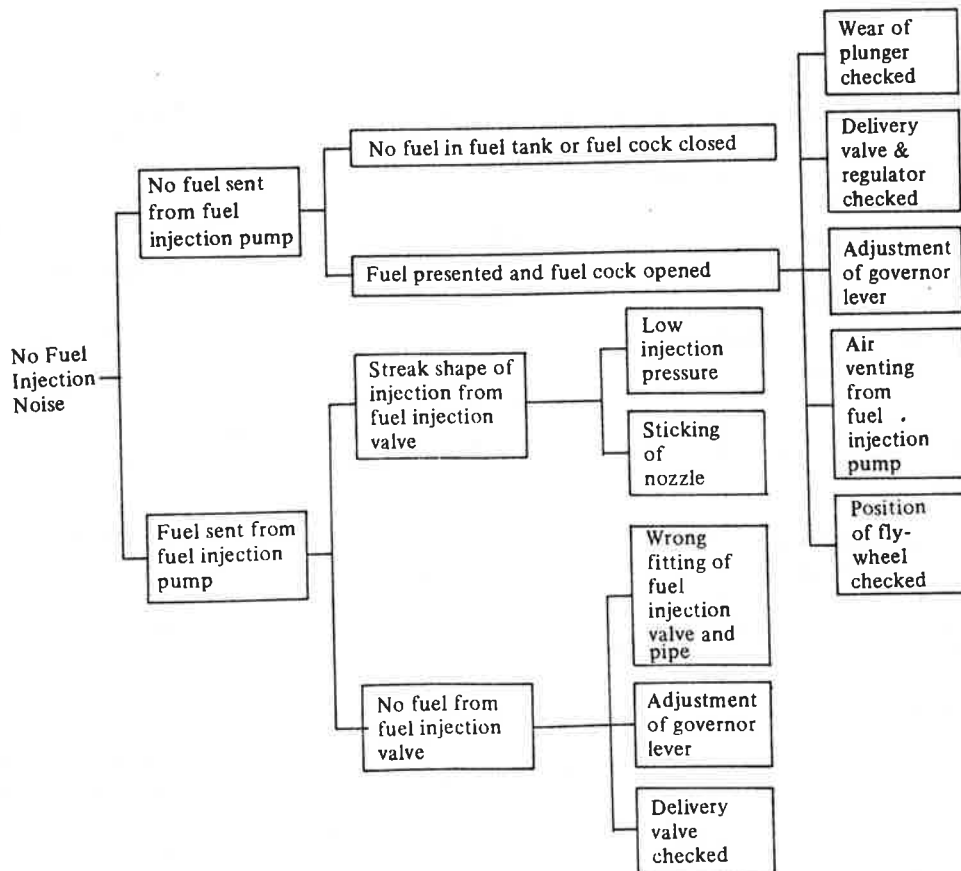

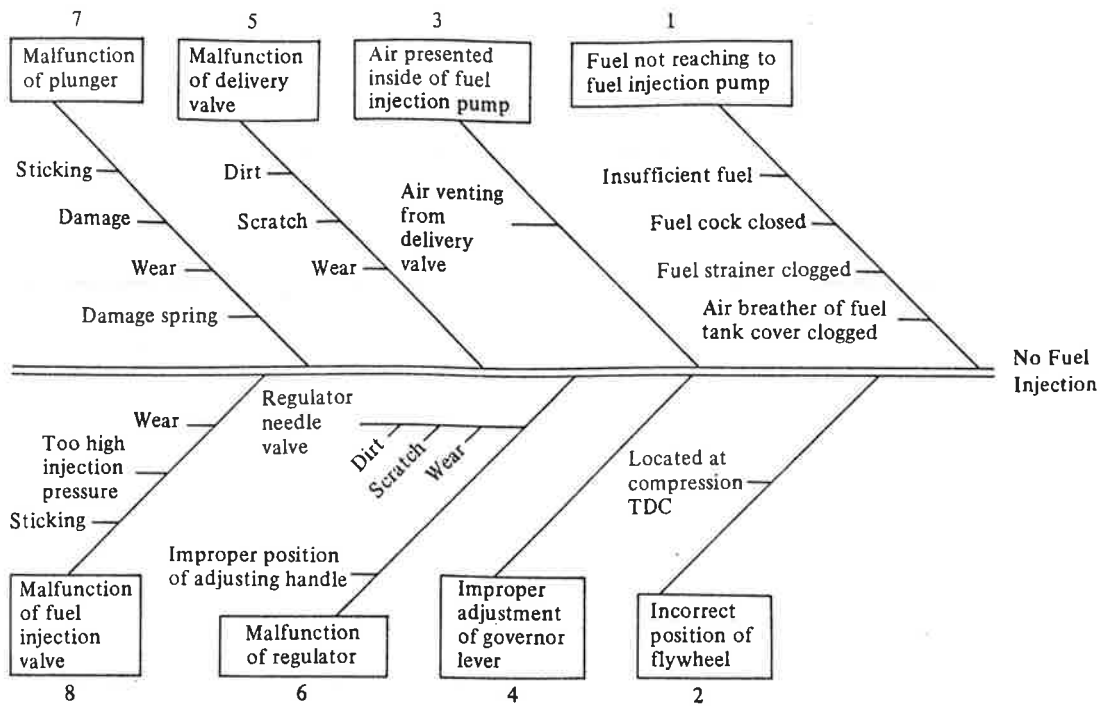

#### Treatment and Instruction

No.	Cause	Treatment	Instruction to Engine Operator
1	Fuel not reaching to fuel injection pump. 1) Insufficient fuel. 2) Fuel cock closed. 3) Fuel strainer clogged. 4) Air breather of fuel tank cover clogged.	1) Supply of fuel and air venting 2) Opening of fuel cock. 3) Cleaning of fuel strainer and fuel tank or exchange of fuel strainer. 4) Cleaning of air breather.	1) Checking of oil level gauge, 3) Supplying of fuel, draining from fuel tank and cleaning of strainer.
2	Incorrect position of flywheel.	Change of plunger position by turning the flywheel.	
3	Air presented inside of fuel injection pump.	Air venting.	Air venting procedure.
4	Improper adjustment of governor lever.	Adjustment of governor lever.	
5	Malfunction of delivery valve. 1) Dirt presented. 2) Scratch & wear.	1) Cleaning. 2) Correction or replacement.	1) Cleaning procedure. Avoiding misplacement of parts. Handling of fuel.

No.	Cause	Treatment	Instruction to Engine Operator
6	Malfunction of regulator. 1) Improper position of adjusting handle. 2) Dirt found on regulator. 3) Scratched or worn regulator needle valve.	1) Setting of adjusting handle to the running position. 2) Washing. 3) Correction or replacement.	1) Handling of fuel. 2) Washing procedure. Handling of fuel.
7	Malfunction of plunger. 1) Sticking of plunger. 2) Damaged or worn plunger. 3) Damaged plunger spring.	1) Washing or replacement. 2) Replacement of both plunger and barrel. 3) Replacement.	1) Handling of fuel. 2) Assembling of plunger.
8	Malfunction of fuel injection valve. 1) Sticking of needle valve. 2) Too high fuel injection pressure. 3) Wear of needle valve.	1) Washing. 2) Adjustment of fuel injection pressure 160 kg/cm <sup>2</sup> . 3) Replacement of needle valve with needle valve case.	1) Handling of fuel.

#### 6-2-2. Compressed Air Leakage

If the compressed air leakage occurs, the temperature of combustion chamber will not raise sufficiently, resulting in no firing and consequently no starting of engine.

Compressed air may be leaked at the following four places as indicated in the figure below:

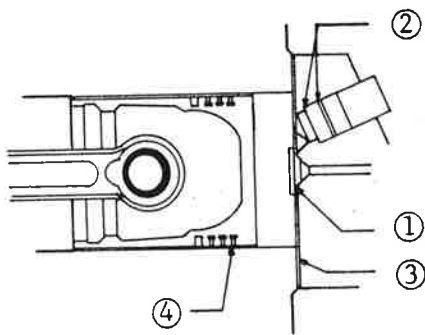

- (1) Clearance of piston pin, piston ring and cylinder liner.
- (2) Suction or exhaust valve seat.
- (3) Air-tight surface due to gasket packing.
- (4) Pre-combustion chamber packing.

Directions of compressed air leakage are two in number. One direction is toward the cylinder side; other, to inside the crankcase.

Therefore, it is wise to detect first the direction of leakage in determining the cause of trouble.

When compressed air leakage is occurring, air leaking noise will be heard. Examine the location of the leakage, and determine the causes systematically in the following order:

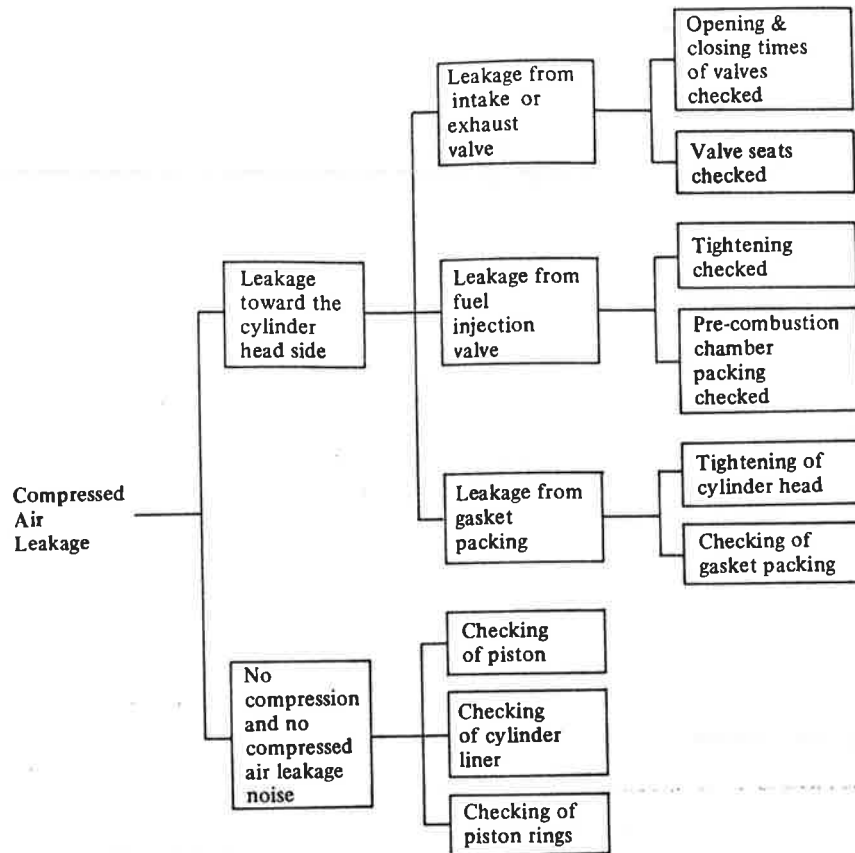

Major causes of compressed air leakage may be considered to be as follows:

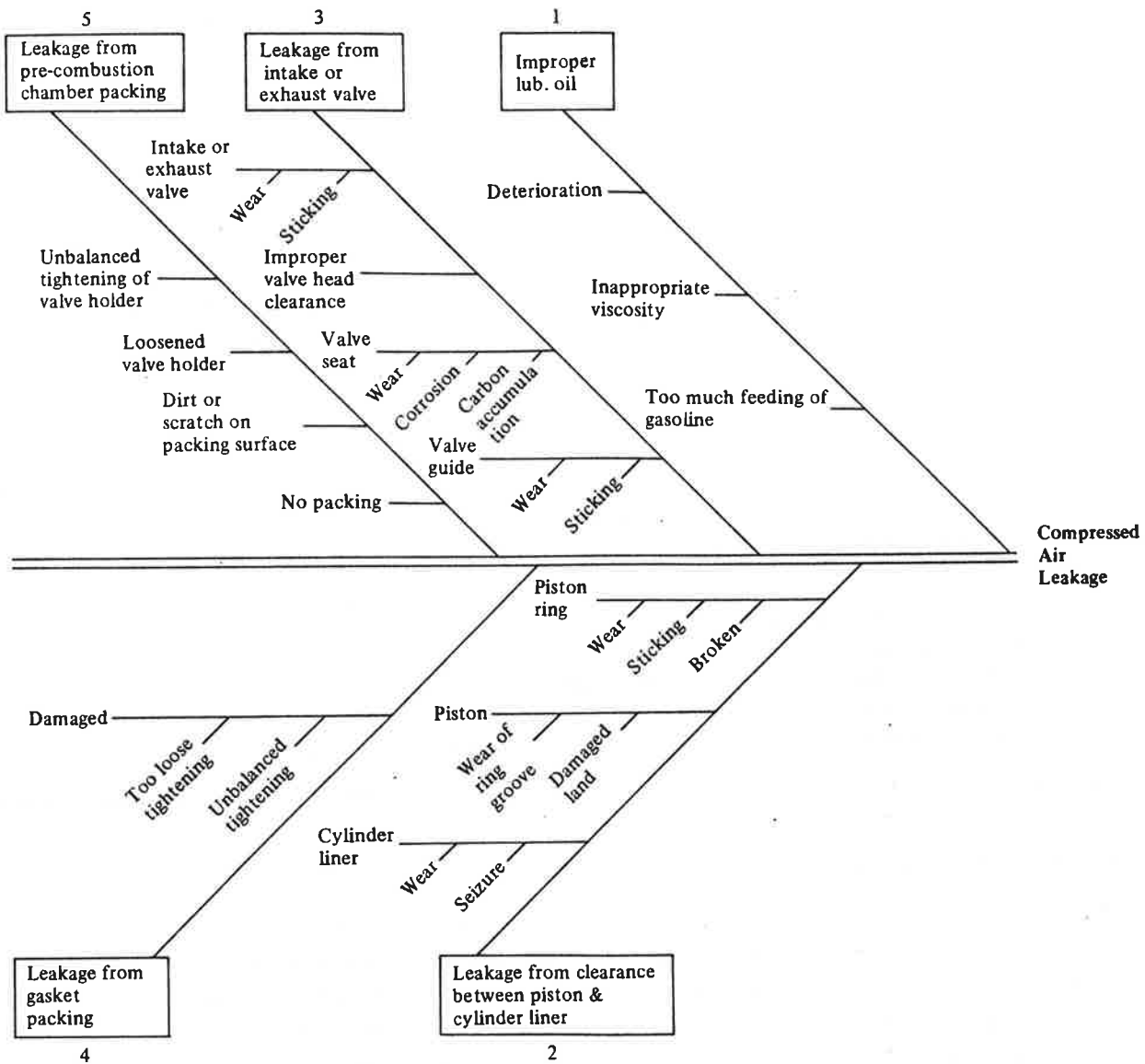

Treatment and Instruction

No.	Cause	Treatment	Instruction to Engine Operator
1	Improper lubricating oil. 1) Deterioration of lub. oil. 2) Inappropriate viscosity 3) Too much feeding of gasoline.	1) Replacement. 2) Replacement. 3) Manually turn the engine for few turns.	1) Handling of lub. oil. 2) Handling of lub. oil. 3) Starting with gasoline feeding.
2	Leakage from clearance between piston and cylinder liner.		

No.	Cause	Treatment	Instruction to Engine Operator
	1) Sticking of piston ring. 2) Broken or worn piston ring. 3) Damaged land of piston and worn piston ring groove. 4) Seizure and wear of cylinder liner.	1) Washing or replacement. 2) Replacement. 3) Replacement. 4) Replacement.	1) Handling of air cleaner. 2) Handling of lub. oil. 3) Replenishment of cooling water. 4) No overloading recommended.
3	Leakage from intake or exhaust valve. 1) Improper valve head clearance. 2) Carbon accumulation, corrosion and wear of valve seat. 3) Sticking or wear of valve guide. 4) Sticking or wear of intake or exhaust valve.	1) Adjustment of intake and exhaust valves. 2) Lapping of suction and exhaust valves. 3) Replacement (with cylinder head). 4) Cleaning or replacement.	1) Adjustment of intake and exhaust valves. 2) Selection of fuel. 3) Selection of fuel. Feeding of fuel.
4	Leakage from gasket packing. 1) Damaged gasket packing due to unbalanced tightening or too loose tightening.	1) Replacement.	1) Periodical retightening.
5	Leakage from pre-combustion chamber packing. 1) Unbalanced tightening or loosened valve holder. 2) Dirt or scratch on packing surface or no packing.	1) Retightening in balanced order. 2) Replacement of packing.	

### 6-2-3. Heavy Hand Cranking

In order to start up the engine easily, it is necessary to have the engine turned lightly by hands. However, if the hand cranking of engine is heavy, the air compression will not be carried out sufficiently; thus, temperature due to compression will not rise enough to provide the firing of fuel, and consequently results in difficult starting. Naturally, even if the starting is somehow possible, the output during running will not reach the top performance.

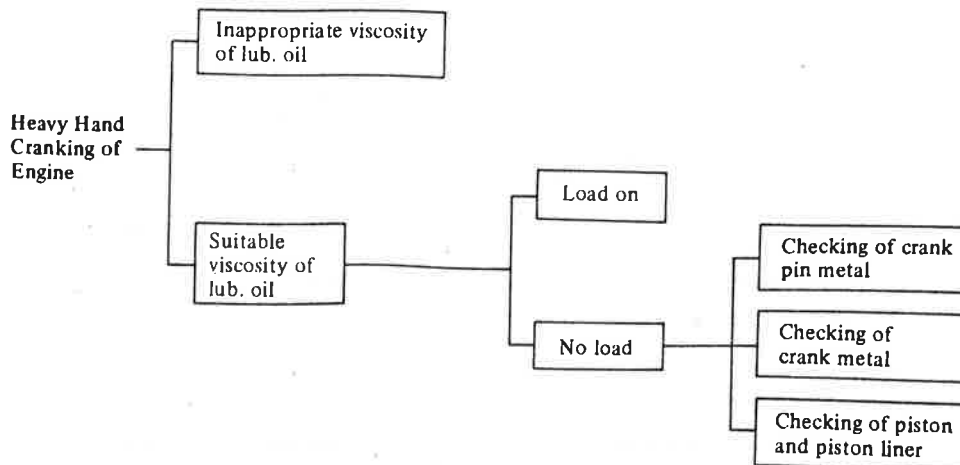

When the hand cranking of engine is heavy, the following causes may be considered:

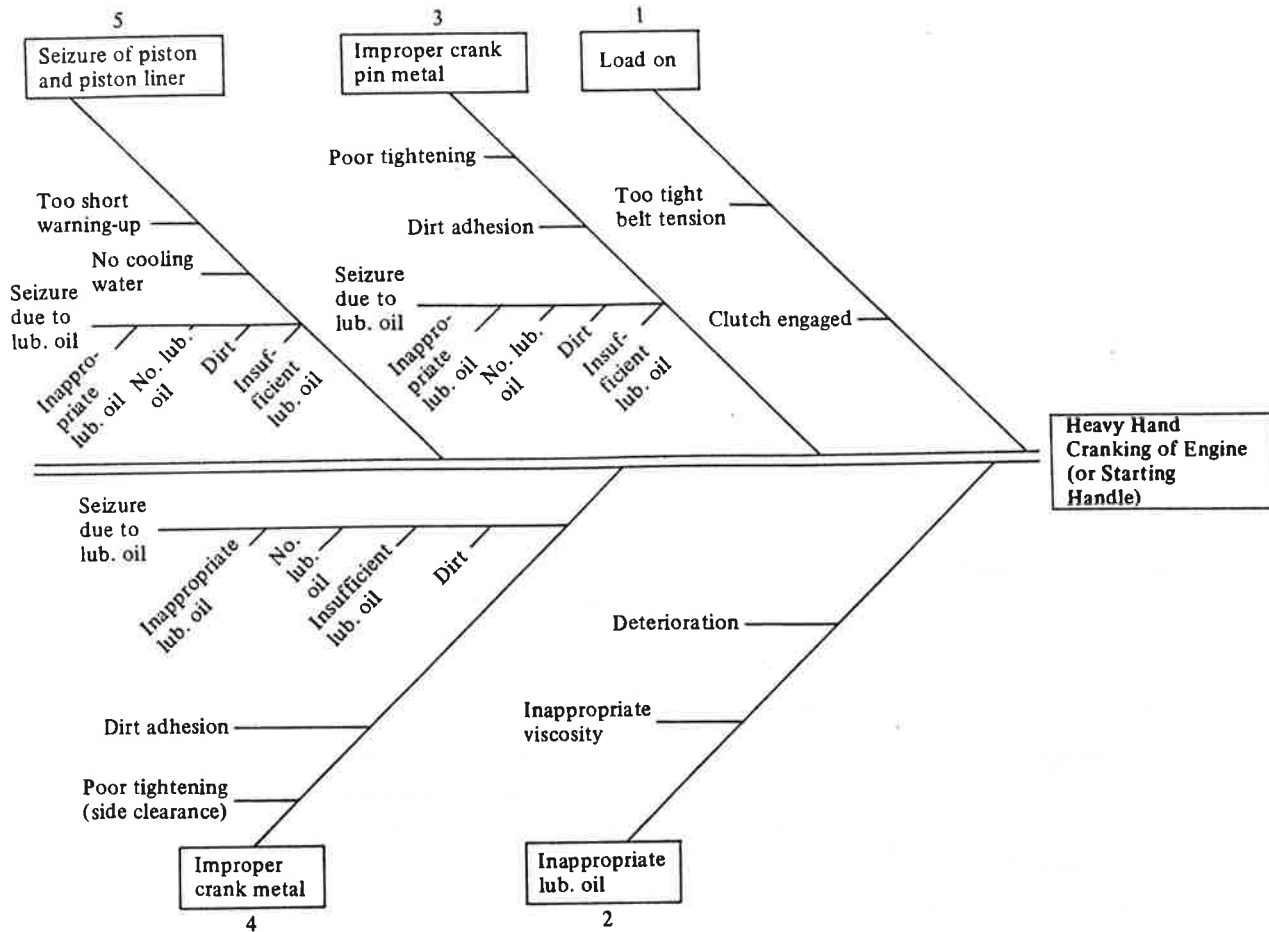

Treatment and Instruction

No.	Cause	Treatment	Instruction to Engine Operator
1	Load on. 1) Too tight belt tension. 2) Clutch engaged.	1) Adjustment of belt tension. 2) Disengaged the clutch.	1) Belt tension. 2) Disengagement of the clutch and starting of engine.
2	Inappropriate lub. oil. 1) Deterioration. 2) Inappropriate viscosity.	1) Replacement. 2) Replacement.	1) Replacement frequency of lub. oil. 2) Selection of lub. oil.
3	Improper crank pin metal. 1) Poor tightening. 2) Dirt adhesion. 3) Seizure due to lub. oil	1) Tightening with specified torque. 2) Washing or replacement. 3) Replacement.	1) Cleaning or handling of crank pin metal. 2) Handling of lub. oil.
4	Improper crank metal. 1) Poor tightening. 2) Dirt adhesion. 3) Seizure due to lub. oil	1) Replacement of packing and inserting of the metal completely. 2) Cleaning or replacement. 3) Replacement of lub. oil.	1) Use of genuine parts. 2) Cleaning or handling of the metal. 3) Handling of lub. oil.

No.	Cause	Treatment	Instruction to Engine Operator
5	Seizure of piston and cylinder liner. 1) Too short warning-up. 2) No or insufficient cooling water. 3) Seizure due to lub. oil.	1) Replacement of seized parts. 2) Replacement of seized parts. 3) Replacement of seized parts.	1) Warming-up. 2) Replenishment of cooling water. 3) Handling of lub. oil.

#### 6-2-4. Cold Engine due to Too Low Ambient Temperature

Even if the fuel injection is normal with sufficient compression, during the winter, the ambient temperature is low. Consequently, the starting is naturally difficult as comparing with warm seasons. This is a natural condition, not a trouble in engine.

In low temperature, the lub. oil becomes much viscous, turning of starting handle becomes heavier, and the temperature of compressed air does not rise to a sufficient level.

All of these cause the firing of fuel difficult. Therefore in order to facilitate it, the following steps should be recommended.

1. During the winter season, use SAE No. 20 or 10W-30 lub. oil. (Refer to page 20)
2. Employ an agent for aiding easy starting. Starting gasoline or automobile gasoline should be fed from the gasoline cup. Feed about 1 cc of such gasoline at one application. If too much gasoline is fed carelessly at one time, thin out the lub. oil which is lubricating the piston and cylinder liner, resulting in compression leakage and adversely worsen starting.
3. Pour hot water for cooling water.  
By the above method, starting will be facilitated if the engine is in cold condition.

#### 6-2-5. Difficulty in Starting Regardless of Ambient Temperature When Fuel Injection & Compression are Normal

If the starting is difficult when turning of the starting handle is light, compression is sufficient and the fuel injection is normal, examine the following points:

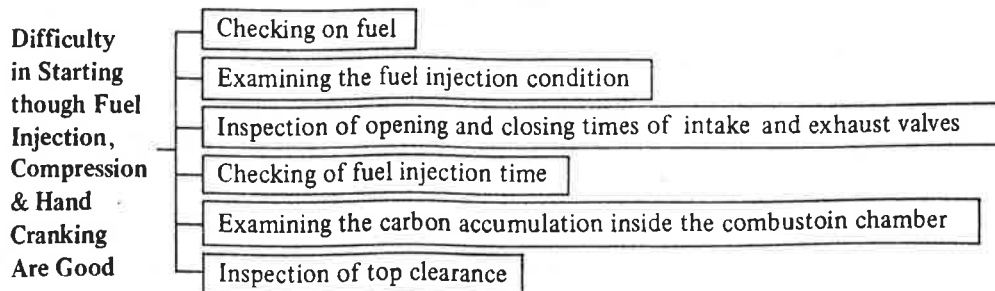

The following causes may be considered for the above points:

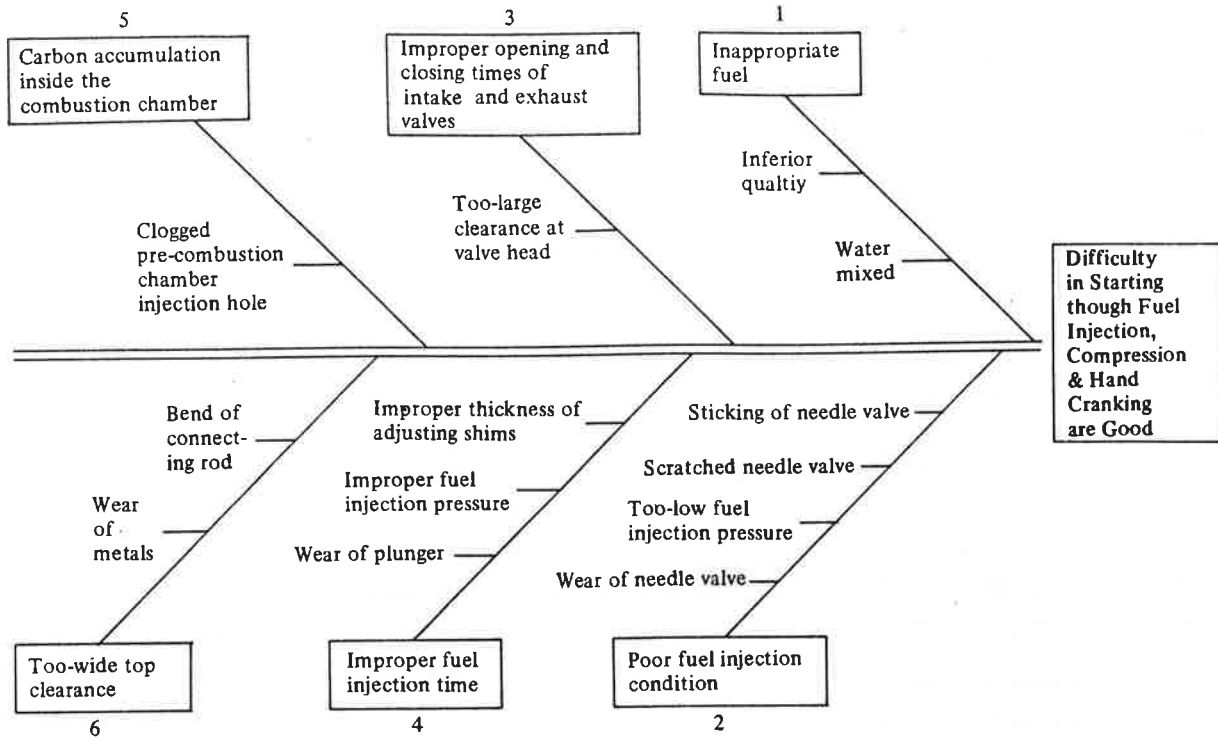

Treatment and Instruction

No.	Cause	Treatment	Instruction to Engine Operator
1	Inappropriate fuel. 1) Inferior quality of lub. oil used. 2) Water mixed in fuel.	1) Replacement. 2) Replacement.	1) Selection of fuel. 2) Handling of fuel and draining.
2	Poor fuel injection condition. 1) Sticking of needle valve. 2) Scratched needle valve. 3) Too-low fuel injection pressure. 4) Wear of needle valve.	1) Cleaning or replacement. 2) Replacement. 3) Adjustment of fuel injection pressure. 4) Replacement.	1) Handling of fuel and draining. 3) Adjustment of fuel injection pressure.
3	Improper opening and closing times of intake and exhaust valves. 1) Too-large clearance at valve head.	1) Adjustment on clearance of intake and exhaust valves.	1) Adjustment on clearance of intake and exhaust valves.
4	Improper fuel injection time. 1) Improper thickness of adjusting shims 2) Improper fuel injection pressure. 3) Wear of plunger.	1) Adjustment of thickness of adjusting shims 2) Adjustment of fuel injection pressure. 3) Replacement.	1) Adjustment on fuel injection time. 2) Adjustment of fuel injection pressure. 3) Handling of fuel.

No.	Cause	Treatment	Instruction to Engine Operator
5	Carbon accumulation inside the the combustion chamber. 1) Clogged pre-combustion chamber injection hole.	1) Removal of carbon.	1) Handling of fuel.
6	Too-wide top clearance. 1) Wear of metals. 2) Bend of connecting rod (due to water hammer, etc.)	1) Replacement. 2) Replacement.	1) Handling of lub. oil. 2) Proper operation of working machine.

### 6-3. Disordered Running

Even if the starting is possible, unless the engine runs orderly, the working performance will not be at the top level. Furthermore, if the engine is operated in that condition for long time, the degree of trouble will also increase accordingly, and consequently may incur the the dangerous accident.

Stop the engine immediately and determine the causes of trouble as early as possible.

During the running of engine, if the following conditions become apparent, search for the cause:

1. Oil light rotor not turning.
2. Abnormal noise during running.
3. Bad colored exhaust.
4. Output decrease.
5. Hunting.
6. Momentary high-speed revolution.
7. Reverse revolution at starting.

#### 6-3-1. Oil Light Rotor Not Turning

If the engine is operated in such condition, seizure of piston, cylinder liner, crankshaft, crank metal, or other working parts will occur. In such case, immediately stop the engine, and check why the lub. oil is not circulating. Check for this in the following order:

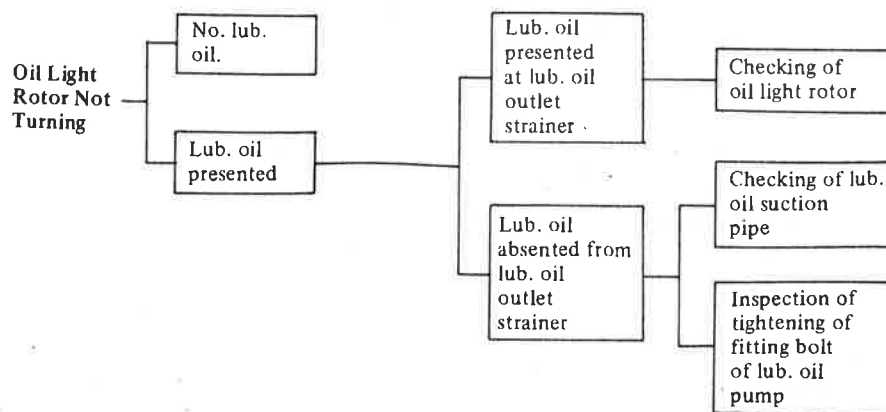

For causes of oil light rotor not turning, the followings may be considered:

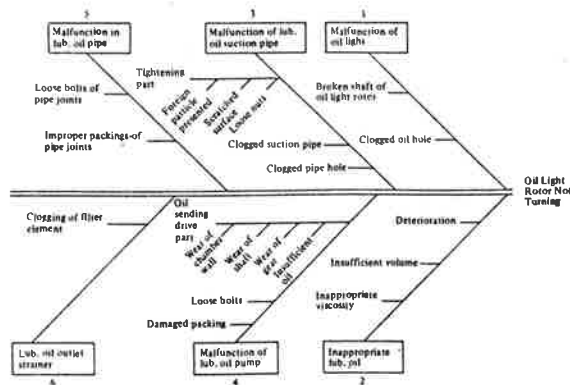

**Treatment and Instruction**

No.	Cause	Treatment	Instruction to Engine Operator
1	Malfunction of oil light. 1) Broken shaft of oil light rotor. 2) Clogged oil hole.	1) Replacement of oil light rotor. 2) Cleaning.	
2	Inappropriate lub. oil. 1) Insufficient volume 2) Deterioration 3) Inappropriate viscosity.	1) Replacement. 2) Replacement. 3) Replacement.	Handling of lub. oil.
3	Malfunction of lub. oil suction pipe. 1) Air suction due to malfunction of tightening part. a. Loose pipe joint bolts. b. Inferior aluminum packings for lub. oil pump bolts. c. Scratched surface. d. Foreign particles presented. 2) Clogged suction pipe. 3) Clogged pipe hole.	a. Retightening b. Replacement of aluminum packings. c. Correction or replacement. d. Cleaning. 2) Cleaning. 3) Cleaning.	1) Cleaning of lub. oil suction pipe. Handling of lub. oil. Exchange of lub. oil. 2) Cleaning.
4	Malfunction of lub. oil pump. 1) Damaged packing 2) Loose bolts. 3) Insufficient oil from oil sending drive part. 4) Wear of gear, shaft and chamber wall.	1) Replacement. 2) Retightening. 3) Feeding of oil to the lub. oil pump. 4) Replacement of lub. oil pump.	Handling of lub. oil.
5	Malfunction in lub. oil pipe. 1) Loose bolts of pipe joints. 2) Improper packings of pipe	1) Retightening. 2) Replacement of packings.	
6	Lub. oil outlet strainer. 1) Clogging of filter element.	1) Cleaning of the strainer 2) Replacement of lub. oil.	Handling of the strainer. Draining from the strainer. Handling of lub. oil.

### 6-3-2. Abnormal Noise During Running

At the time of starting of diesel engine, a high-pitch noise will be produced. This is called the diesel knocking and is caused by pressure created from a large amount of fuel combusted at one time. This is no malfunction. However during the engine running, if abnormal exhaust sound or metallic knocking noise will be produced, stop the engine immediately and determine the causes.

When abnormal noise will be produced during the engine running, check the causes of trouble in the following order:

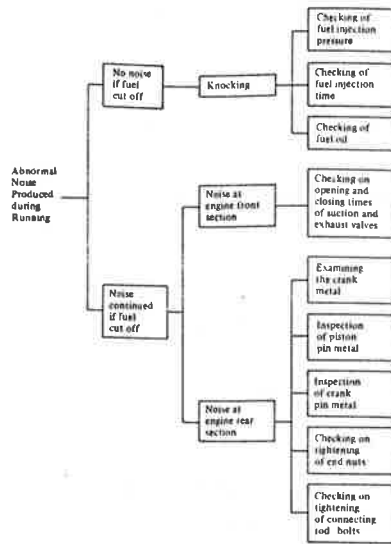

The following causes will be considered with regard to abnormal noise produced during running:

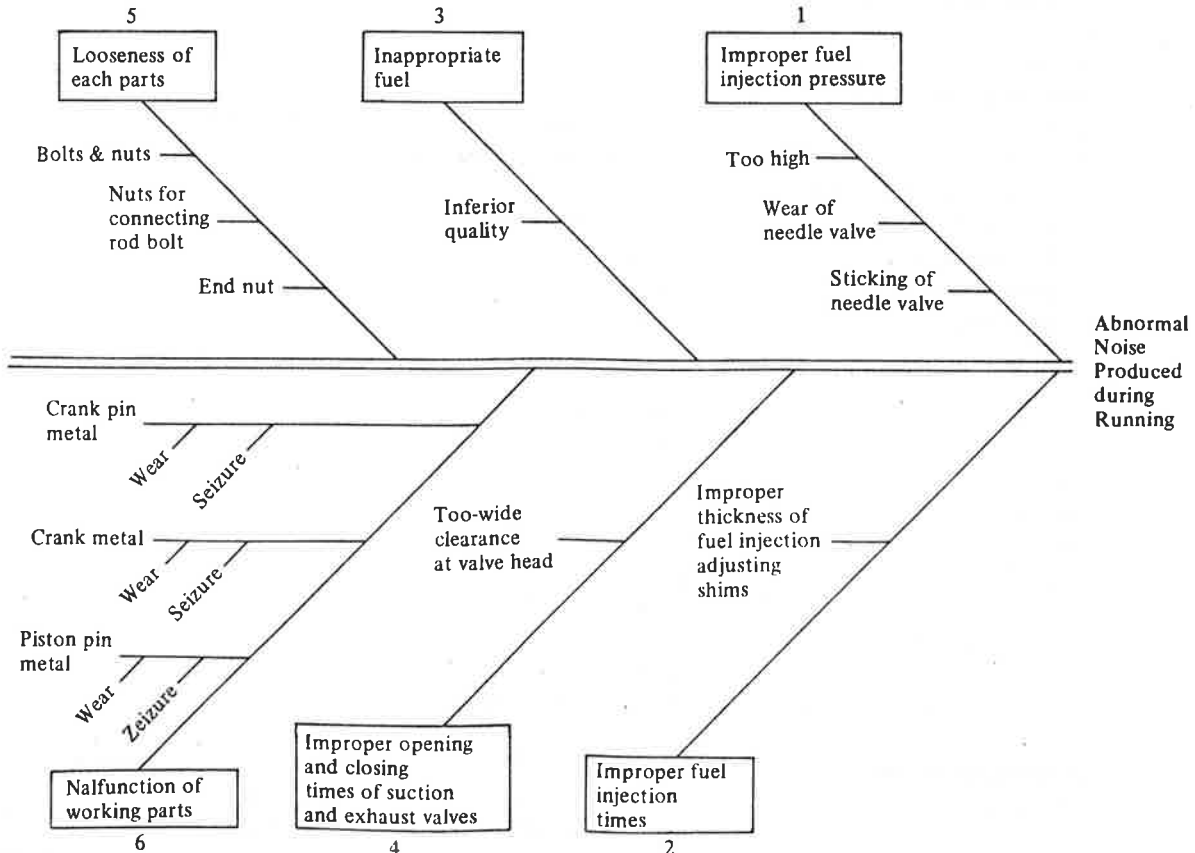

Treatment and Instruction

No.	Cause	Treatment	Instruction to Engine Operator
1	Improper fuel injection pressure. 1) Sticking of needle valve. 2) Wear of needle valve. 3) Too-high fuel injection pressure.	1) Cleaning or replacement. 2) Replacement. 3) Adjustment of fuel injection pressure.	1) Handling of fuel. 2) Handling of fuel.
2	Improper fuel injection time. 1) Improper thickness of fuel injection time adjusting shims.	1) Adjustment of fuel injection time.	
3	Inappropriate fuel. 1) Inferior quality fuel.	1) Replacement.	Handling of fuel.
4	Improper opening and closing times of intake and exhaust valves. 1) Too-wide clearance at valve head.	1) Adjustment on clearance of intake and exhaust valves.	1) Adjustment on clearance of intake and exhaust valves.
5	Looseness of each parts. 1) Looseness of endnut. 2) Looseness of nuts for connecting rod bolts. 3) Looseness of bolts and nuts.	1) Retightening. 2) Retightening of the nuts and bending of bend lock washers. 3) Retightening.	Periodical retightening of major bolts and nuts.
6	Malfunction of working parts. 1) Seizure and wear of crank pin metal. 2) Seizure and wear of crank metal. 3) Seizure and wear of piston pin metal.	1) Replacement. 2) Replacement. 3) Replacement.	Handling of lub. oil. No working.

**6-3-3. Bad Colored Exhaust**

Condition of engine may be fairly well determined from the exhaust color. Also from different colors of exhaust, one can determine what part of engine is in disorder, thus applying this method for detection of trouble, one can easily learn the causes of trouble.

The relations between the exhaust color and the trouble are as follows:

Colorless or light blue color – good running condition.

Blueish-white smoke – incomplete combustion or burning of lub. oil .

Black smoke – overloading.

If the exhaust is bad colored, determine the cause by the following order:

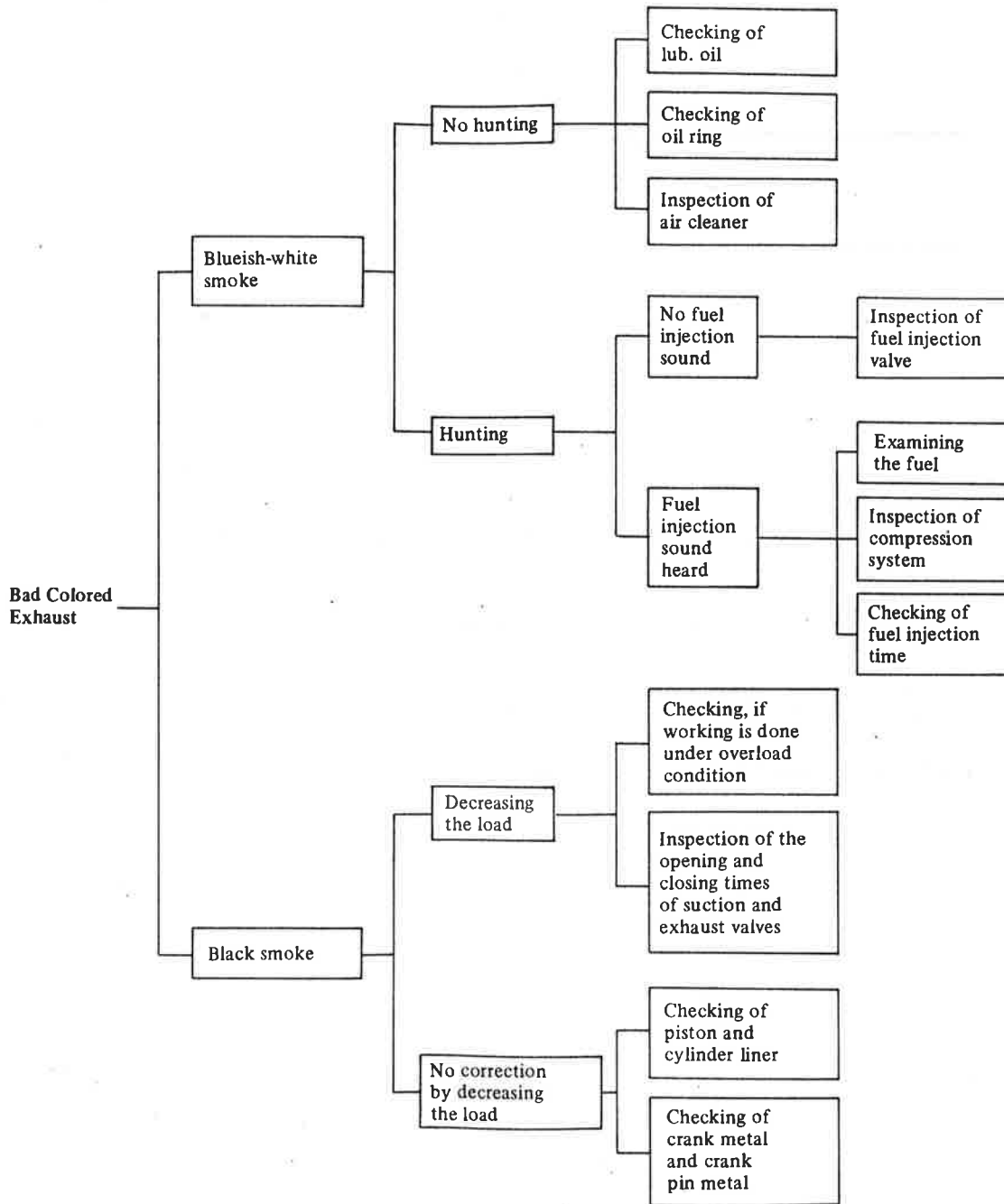

When the exhaust is bad colored, the following causes may be considered:

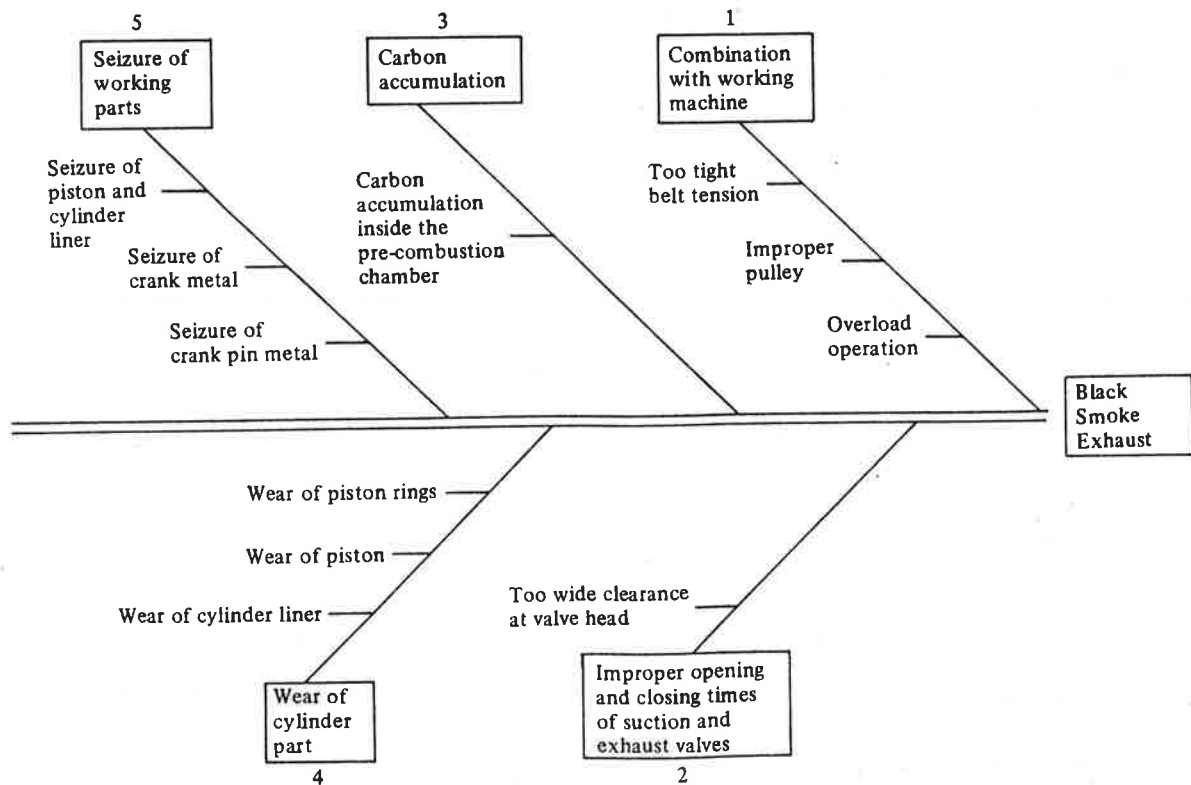
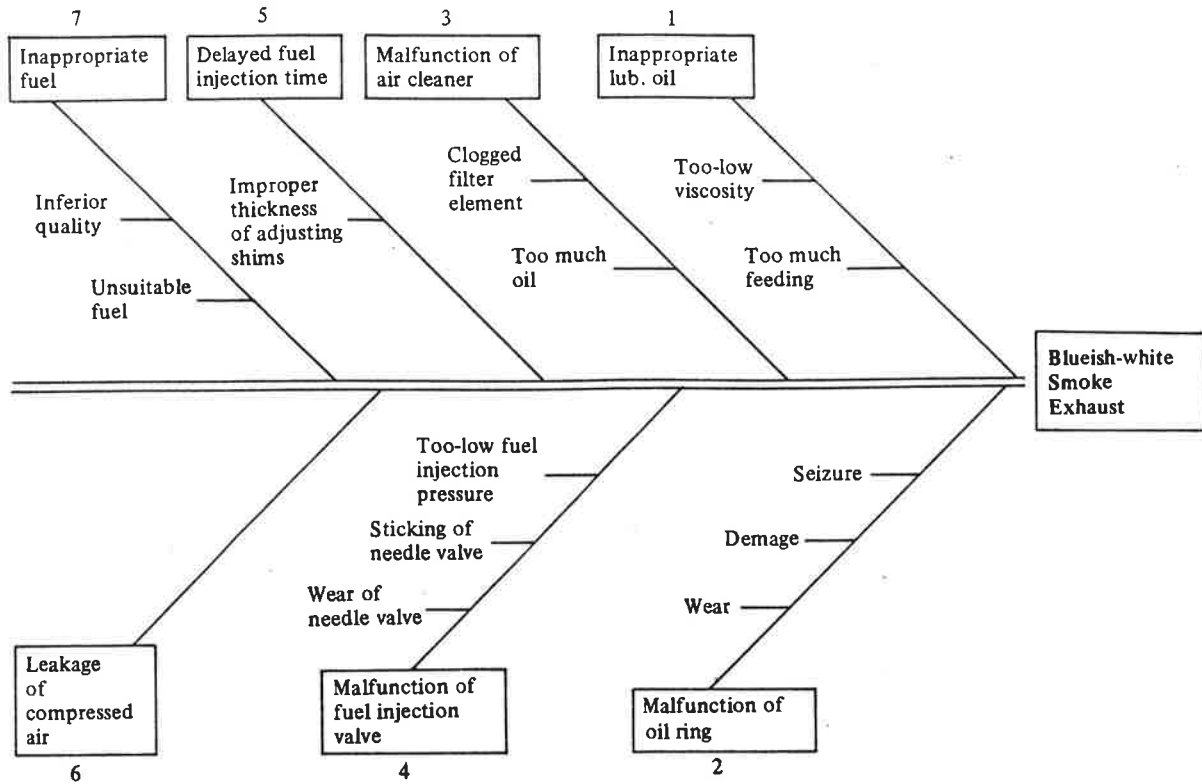

Blueish-white Smoke Exhaust  
Treatment and Instruction

No.	Cause	Treatment	Instruction to Engine Operator
1	Inappropriate lub. oil. 1) Too much feeding. 2) Too-low viscosity.	1) Decreasing the volume to the upper limit of oil level gauge. 2) Replacement of oil level gauge.	1) Handling of lub. oil. 2) Handling of lub. oil.
2	Malfunction of oil ring. 1) Seizure, damage and wear.	1) Replacement.	Handling of lub. oil.
3	Malfunction of air cleaner. 1) Too much oil. 2) Clogged filter element.	1) Lowering of oil to the level of the to hopper side line. 2) Cleaning of filter element.	1) Handling of air. 2) Periodical cleaning of the element.
4	Malfunction of fuel injection valve. 1) Sticking of needle valve. 2) Too-low fuel injection pressure. 3) Wear of needle valve.	1) Cleaning or replacement. 2) Adjustment of fuel injection pressure. 3) Replacement of nozzle.	1) Handling of fuel. 2) Adjustment of fuel injection pressure.
5	Delayed fuel injection time. 1) Too many of the adjusting shims.	1) Adjustment of fuel injection time.	
6	Leakage of compressed air. ("Compressed Air Leakage.")		
7	Inappropriate fuel. 1) Inferior quality fuel used. 2) Unsuitable fuel used.	1) Replacement. 2) Replacement.	Handling of fuel.

Black Smoke Exhaust  
Treatment and Instruction

No.	Cause	Treatment	Instruction to Engine Operator
1	Combination with working machine. 1) Overload operation. 2) Improper diameter of pulley used. 3) Too tight belt tension.	1) Decrease of load. 2) Replacement of pulley. 3) Adjustment of belt tension.	1) Working method. 2) Selection of pulley. 3) Adjustment of belt tension.
2	Improper opening and closing times of intake and exhaust valves. 1) Too-wide clearance at valve head.	1) Adjustment on clearance of intake and exhaust valves.	1) Adjustment on clearance intake and exhaust valves.

No.	Cause	Treatment	Instruction to Engine Operator
3	Carbon accumulation. 1) Carbon accumulation inside the pre-combustion chamber.	1) Cleaning to remove carbon.	1) Handling of fuel.
4	Wear of cylinder part. 1) Wear of piston rings. 2) Wear of piston. 3) Wear of cylinder liner.	1) Replacement of rings. 2) Replacement of piston. 3) Replacement of cylinder liner.	Handling of both fuel and lub. oil.
5	Seizure of piston and cylinder 1) Seizure of piston and cylinder liner. 2) Seizure of crank metal. 3) Seizure of crank pin metal.	1) Correction or replacement. 2) Replacement. 3) Replacement.	Handling of both cooling water and lub. oil.

#### 6-3-4. Output Decrease

If the engine is operated under the overload, that is, beyond the engine top performance, the number of revolution will drop and the black smoke will be exhausted. Naturally working under such condition should be avoided. However, under a good working condition of engine, it usually offers good working performance. Yet if same working becomes impossible as the black smoke is exhausted and the revolution of engine is dropped, this should be considered as abnormality in engine. In such case, determine the cause in the following manner:

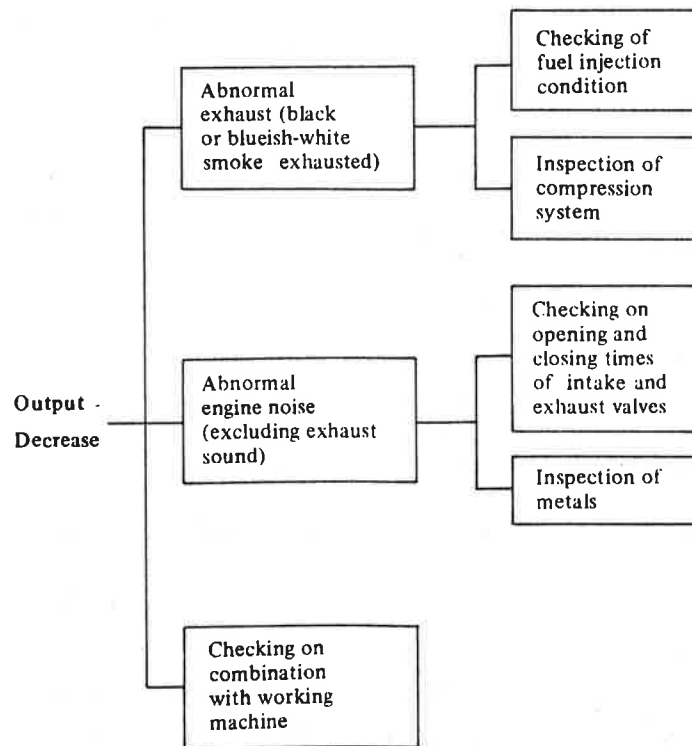

When the output is decreased, the following causes may be considered:

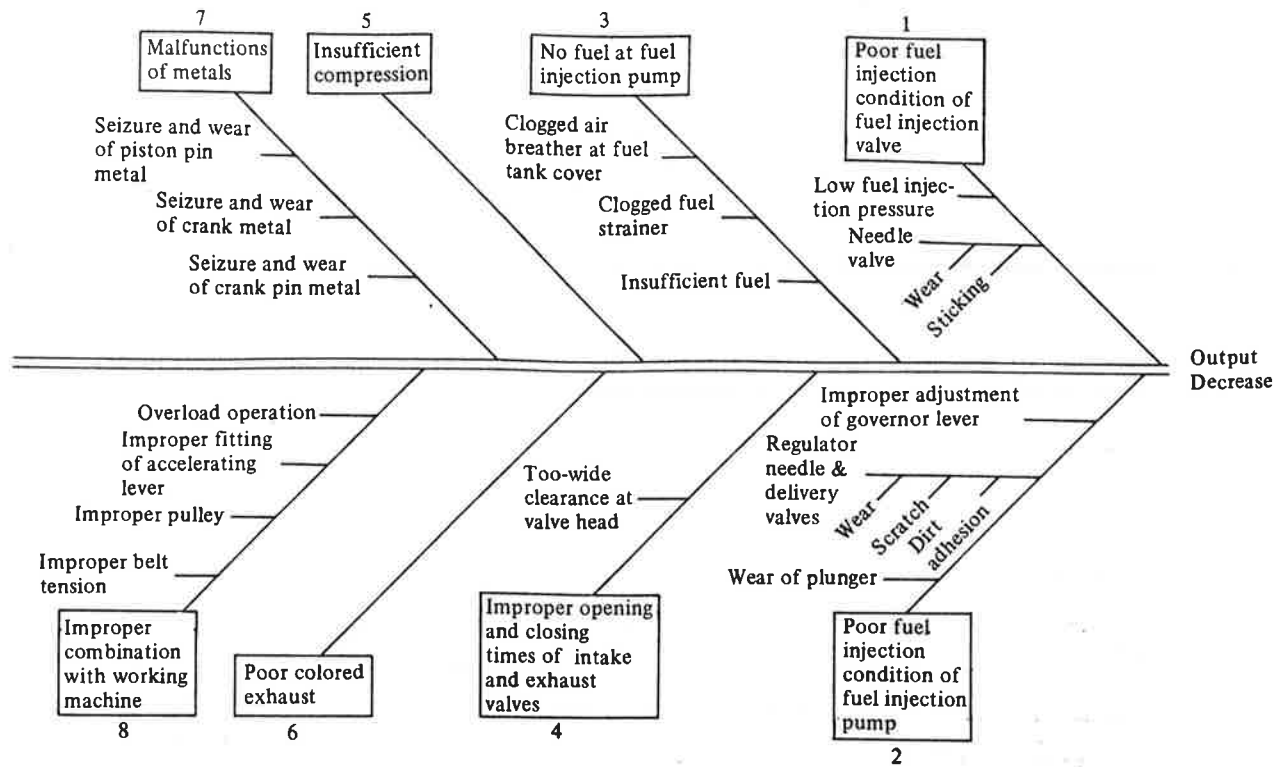

#### Treatment and Instruction

No.	Cause	Treatment	Instruction to Engine Operator
1	Poor fuel injection condition of fuel injection valve. 1) Drop of fuel injection pressure. 2) Sticking and wear of needle valve.	1) Adjustment of fuel injection pressure. 2) Cleaning or replacement.	1) Adjustment of fuel injection pressure. 2) Handling of fuel. Draining from fuel tank.
2	Poor fuel injection condition of fuel injection pump. 1) Improper adjustment of governor lever. 2) Dirt adhesion, scratch or wear of delivery valve. 3) Dirt adhesion, scratch or wear of delivery valve. 4) Wear of plunger.	1) Adjustment of governor lever. 2) Cleaning or replacement. 3) Cleaning or replacement. 4) Replacement.	1) Adjustment of governor lever. 2) Handling of fuel. 3) Handling of fuel. 4) Handling of fuel.
3	No fuel at fuel injection pump. 1) Insufficient fuel. 2) Clogged fuel strainer. 3) Clogged air breather at fuel tank cover.	1) Replenishing of fuel and air. 2) Cleaning of fuel strainer. 3) Cleaning.	1) Air venting. 2) Handling of fuel oil.

No.	Cause	Treatment	Instruction to Engine Operator
4	Improper opening and closing times of intake and exhaust valves. 1) Too-wide clearance at valve head.	1) Adjustment on clearance of intake and exhaust valves.	1) Adjustment on clearance of intake and exhaust valves.
5	Insufficient compression due to leakage.	("Compressed Air Leakage.")	
6	Poor colored exhaust.	("Bad Colored Exhaust.")	
7	Malfunction of metals. 1) Seizure and wear of crank pin metal. 2) Seizure and wear of crank metal. 3) Seizure and wear of piston pin metal.	1) Replacement. 2) Replacement. 3) Replacement.	1) Handling of lub. oil. 2) Handling of lub. oil. 3) Handling of lub. oil.
8	Improper combination with working machine. 1) Overload operation. 2) Improper fitting of accelerating lever. 3) Improper diameter of pulley. 4) Too tight belt tension.	1) Correction on working condition 2) Adjustment of accelerating lever. 3) Replacement of pulley. 4) Adjustment on belt tension.	1) Proper working procedure. 2) Fitting of accelerating lever. 3) Selection of pulley. 4) Tensioning of belt.

#### 6-3-5. Hunting

If the engine runs with hunting, the working operation will be difficult, lowering performance of working machine which affects the overall working efficiency.

In such case, determine the cause of trouble in the following manner:

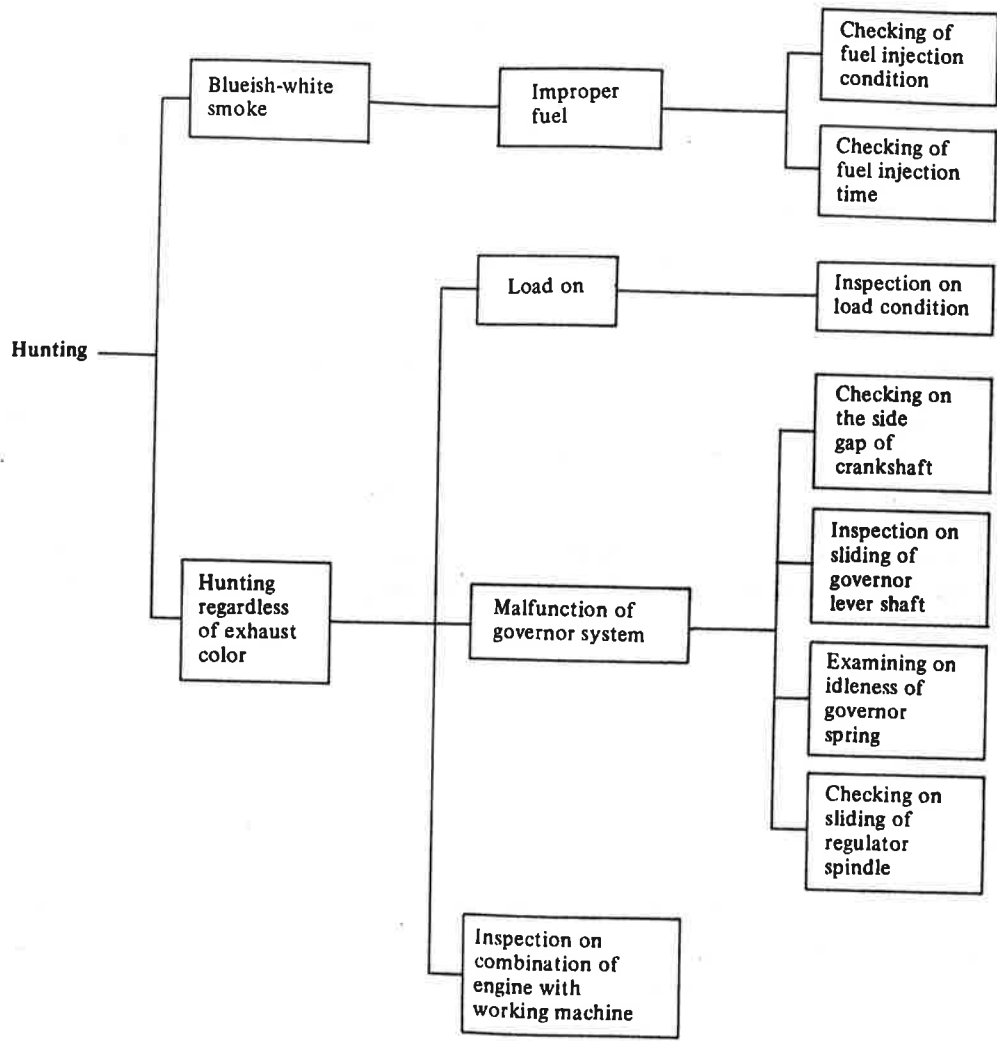

The following causes may be considered in case of hunting:

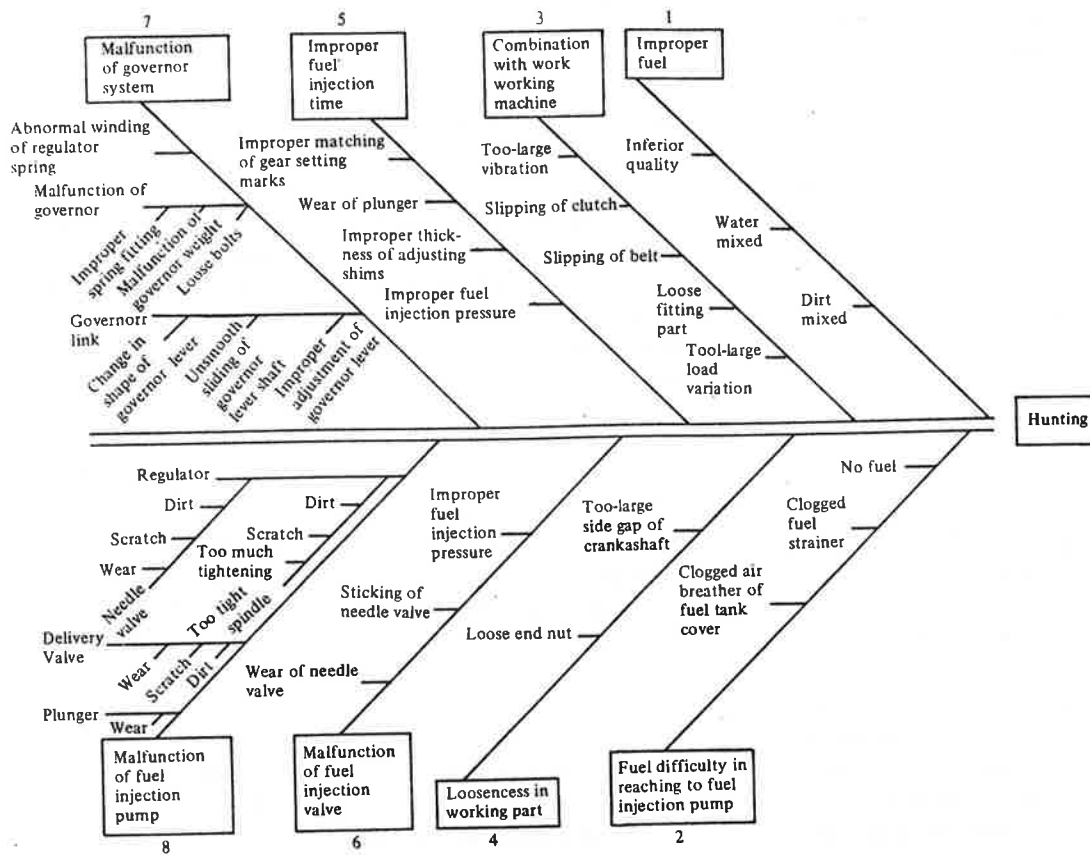

### Treatment and Instruction

No.	Cause	Treatment	Instruction to Engine Operator
1	Improper fuel. 1) Inferior quality, water mixed or dirt mixed.	1) Replacement.	1) Handling of fuel.
2	Fuel difficulty in reaching to fuel injection pump. 1) No fuel. 2) Clogged fuel strainer. 3) Clogged air breather of fuel tank cover.	1) Fuel supply and air venting. 2) Cleaning. 3) Cleaning.	1) Handling of fuel and air venting. 2) Handling and cleaning. 3) Handling and cleaning.
3	Combination with working machine. 1) Too large load variation 2) Loose fitting part. 3) Slipping of belt. 4) Slipping of clutch. 5) Too large vibration.	1) Change of working condition. 2) Retightening. 3) Adjustment of belt tension. 4) Adjustment of clutch. 5) Use of buffer and change of installation.	1) Working method. 2) Periodical retightening. 3) Adjustment of belt tension. 4) Adjustment of clutch.

No.	Cause	Treatment	Instruction to Engine Operator
4	Looseness in working part. 1) Loose endnut. 2) Too large side gap of crank-shaft.	1) Retightening. 2) Adjustment of the gap or replacement of crank metal.	1) Periodical checking.
5	Improper fuel injection time. 1) Improper fuel injection pressure. 2) Improper thickness of adjusting shims. 3) Wear of plunger. 4) Improper matching of gear setting marks.	1) Adjustment of fuel injection pressure. 2) Adjustment of fuel injection time. 3) Replacement of plunger. 4) Resetting.	1) Adjustment of fuel injection pressure. 2) Adjustment of fuel injection time. 3) Handling of fuel. 4) Handling of fuel.
6	Malfunction of fuel injection valve. 1) Improper fuel injection pressure. 2) Sticking of needle valve. 3) Wear of needle valve.	1) Adjustment of fuel injection pressure. 2) Cleaning or replacement. 3) Replacement.	1) Adjustment of fuel injection pressure. 2) Handling of fuel. 3) Handling of fuel.
7	Malfunction of governor system. 1) Malfunction of governor link. a. Improper adjustment of governor lever. b. Unsmooth sliding of governor lever shaft. c. Change in shape of gover governor lever. 2) Malfunction of governor. a. Loose bolts. b. Improper fitting of governor spring. c. Malfunction of governor weight. 3) Abnormal winding of regulator spring.	a. Adjustment of governor lever. b. Cleaning, oiling or lapping. c. Correction or replacement.  a. Retightening. b. Adjustment of idleness of the spring. c. Correction for smooth movement. 3) Adjustment on number of coil.	a. Adjstment of governor lever.
8	Malfunction of fuel injection pump. 1) Malfunction of fuel injection a. Too tight regulator spindle (dirt adhesion, scratch or wear). b. Malfunction of regulator needle valve (dirt adhesion, scratch or wear). 2) Malfunction of delivery valve (dirt adhesion, scratch or wear). 3) Wear of plunger.	a. Cleaning and lapping or replacement with the body. b. Clearning and correction of seat or replacement.  2) Cleaning and correction of seat or replacement. 3) Replacement.	a. Handling of fuel.

### 6-3-6. Momentary High-Speed Revolution

If momentary high-speed revolution occurs at starting up or during engine running, stop the engine immediately by operating the priming lever or the decompression lever. Otherwise, major danger will be incurred shortly. Major causes of trouble in this connection are at the governor system, thus check for the causes in the following manner:

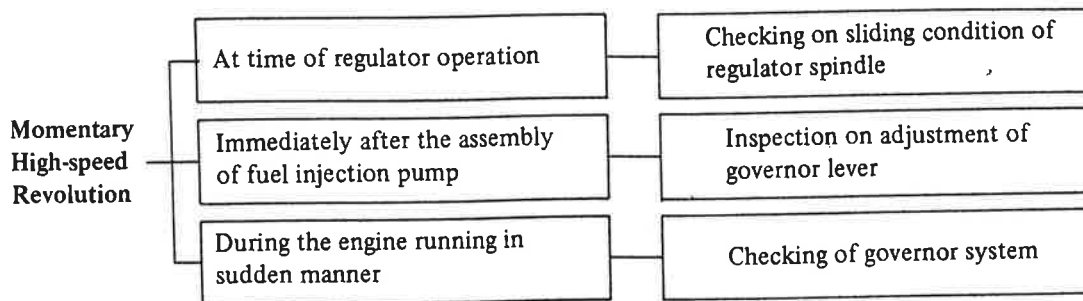

The following causes may be considered in connection with momentary high-speed revolution:

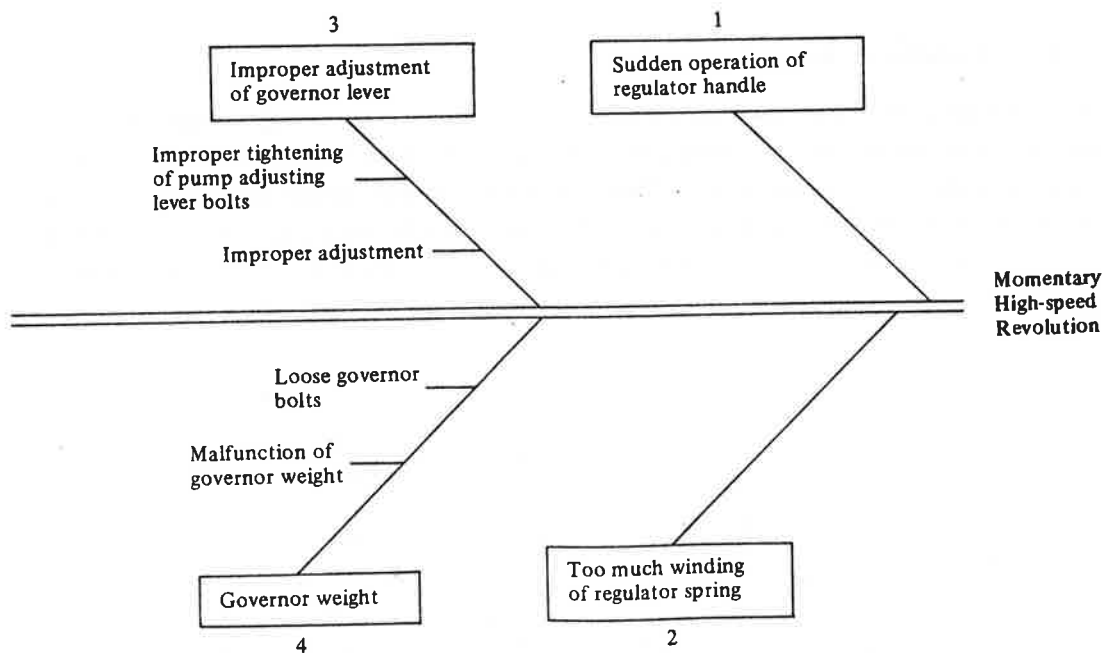

Treatment and Instruction

No.	Cause	Treatment	Instruction to Engine Operator
1	Sudden operating of regulator handle.		Operation of regulator handle.
2	Too much winding of regulator spring.	Adjustment on number of coil.	
3	Improper adjustment of governor lever. 1) Improper adjustment. 2) Improper tightening of pump adjusting lever bolts.	1) Adjustment of governor lever. 2) Adjustment of governor lever.	1) Adjustment of governor lever. 2) Adjustment of governor lever.
4	Governor weight. 1) Loose governor bolts. 2) Malfunction of governor weight.	1) Retightening. 2) Correction for smooth movement.	

6-3-7. Reverse Revolution at Starting

If the engine is to be started by insufficient number of manual turns, the engine might rotate in the reverse direction. If such reverse revolution is continued for sometime, lub. oil will not be pumped by the lub. oil pump, resulting in the seizure of sliding parts. Thus, the reverse revolution should be stopped as soon as possible. Also when the reverse revolution occurred, the starting handle might not detached and it might turn, too. In any of such case, without hasty manner, stop the engine running by operating the decompression lever or the priming lever. When reverse revolution occurred, check for the causes in the following order:

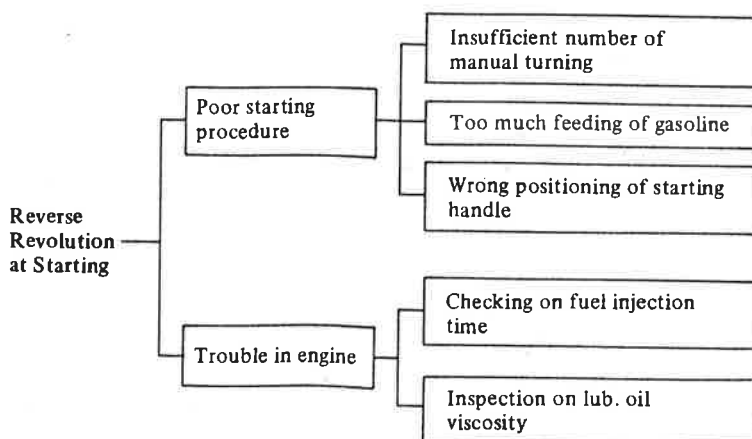

The following causes may be considered in connection with the reverse revolution:

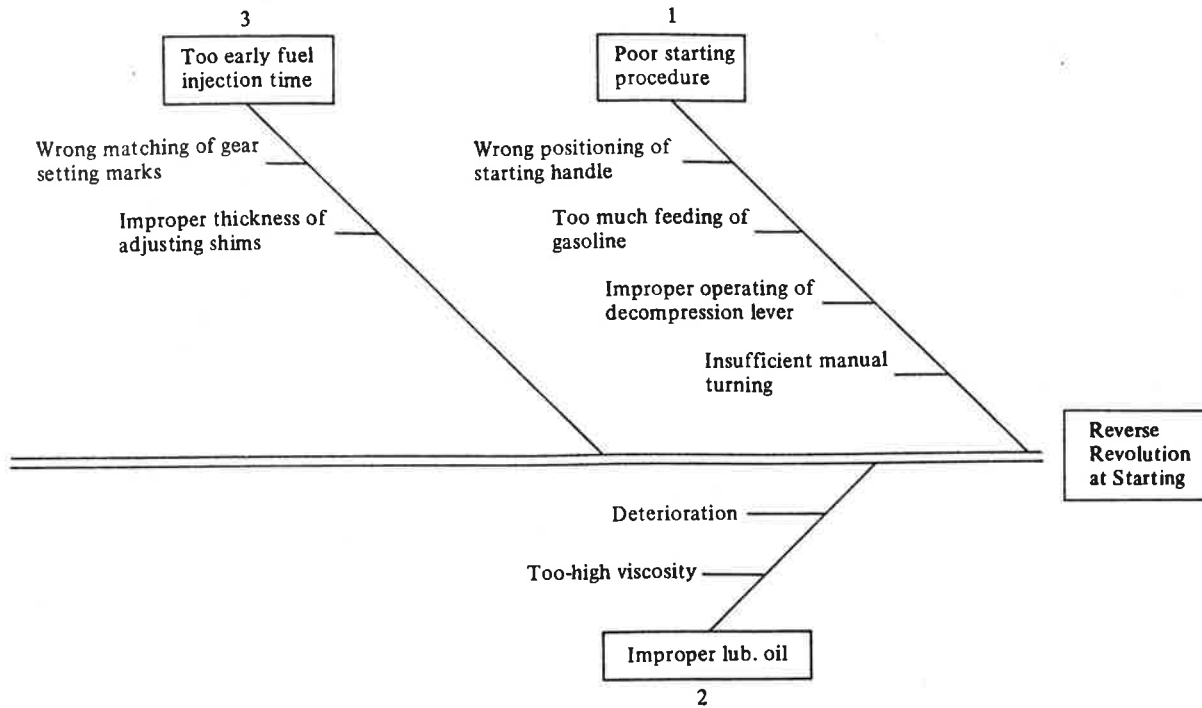

Treatment and Instruction

No.	Cause	Treatment	Instruction to Engine Operator
1	<b>Poor starting procedure.</b> 1) Insufficient manual turning. 2) Improper operating of decompression lever. 3) Too much feeding of gasoline. 4) Wrong positioning of starting handle.	1) Fast hand cranking.	Starting procedure
2	<b>Improper lub. oil.</b> 1) Deterioration. 2) Too high viscosity.	1) Replacement. 2) Replacement.	1) Handling of lub. oil. 2) Handling of lub. oil.
3	<b>Too early fuel injection time.</b> 1) Improper thickness of adjusting shims. 2) Wrong matching of gear setting marks.	1) Adjustment of fuel injection time. 2) Resetting.	1) Adjustment of fuel injection time.

6-4. Sudden Stop of Engine

If the engine stops suddenly during running, mainly the following causes may be considered. This type of trouble usually causes one of major accidents of engine and is specifically a seizure due to careless handling. The causes for this type of trouble are not too difficult in finding; however, the time and know-how are required for the repairing. Thus in order to avoid the seizure type trouble, pay attention to the handling:

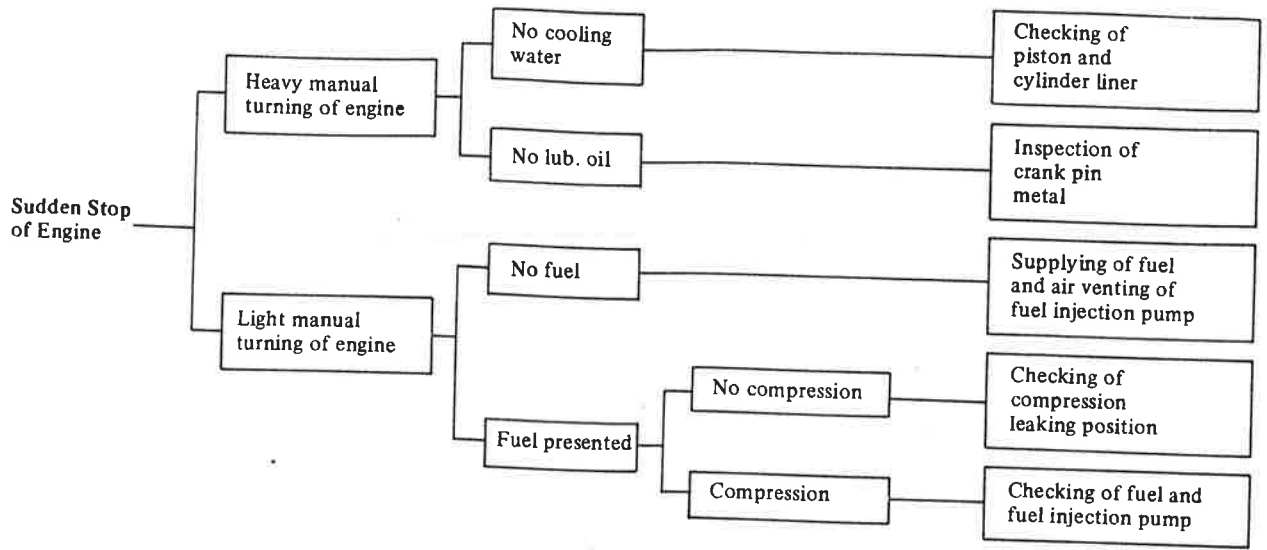

The following causes may be considered in connection with the sudden stop of engine.

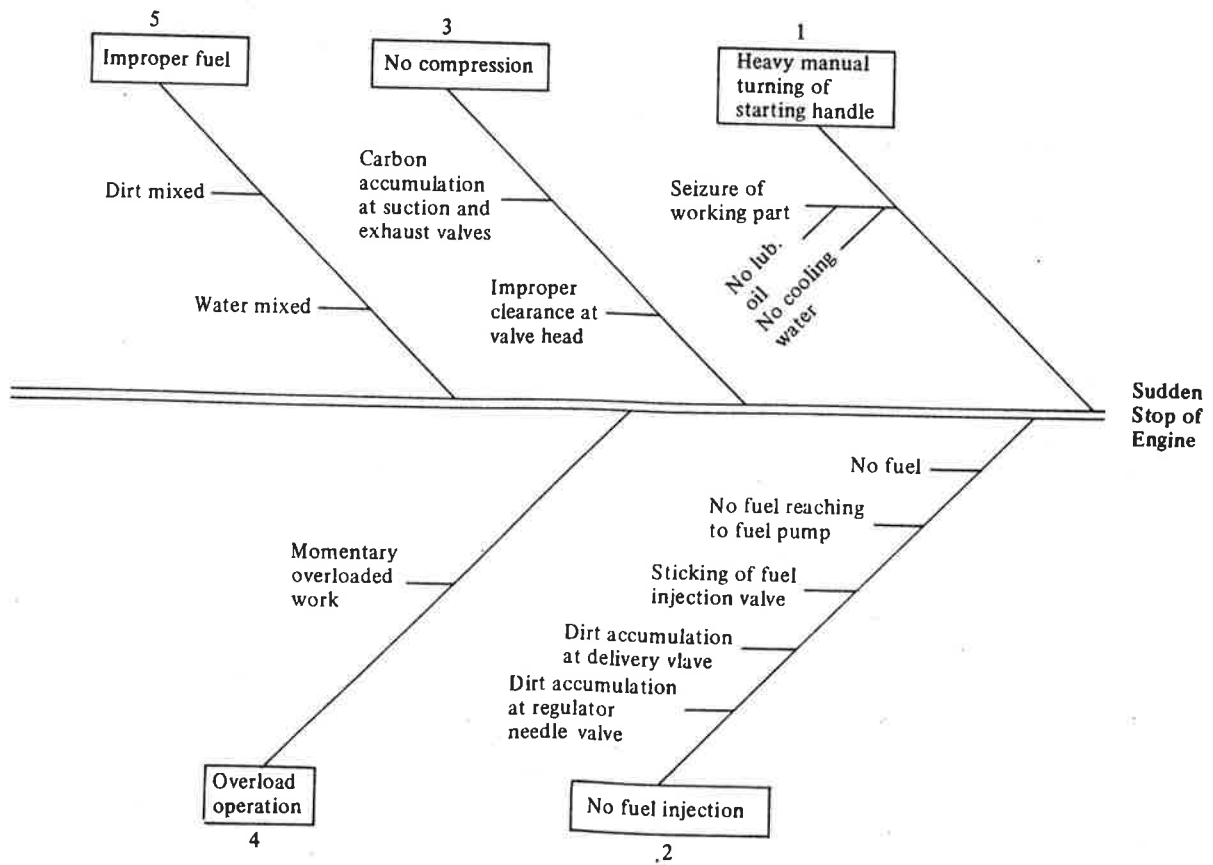

Treatment and Instruction

No.	Cause	Treatment	Instruction to Engine Operator
1	Heavy manual turning of starting handle. 1) Seizure of piston due to no or insufficient cooling water. 2) Seizure of metals due to no or insufficient lub. oil.	1) Replacement of piston and cylinder liner. 2) Replacement of metals.	1) Handling of cooling water. 2) Handling of lub. oil.
2	No fuel injection.		
3	No compression		
4	Overload operation. 1) Momentary overloaded work.	1) Decrease of load.	1) Working method.
5	Improper fuel. 1) Dirt and water mixed.	1) Replacement of fuel and cleaning of fuel tank and fuel strainer.	1) Handling of fuel.

6-5. Oil, Water or Gas Leakage

Oil, water or gas leakage may be usually due to loose bolts and nuts through a long service period. Or it may also occur frequently due to wear or deterioration of packings. For treatments against these causes, checking of the leaking place, retightening of bolts and nuts; and exchange of packings should be necessary. Thus determine the causes by inspecting in the following manner:

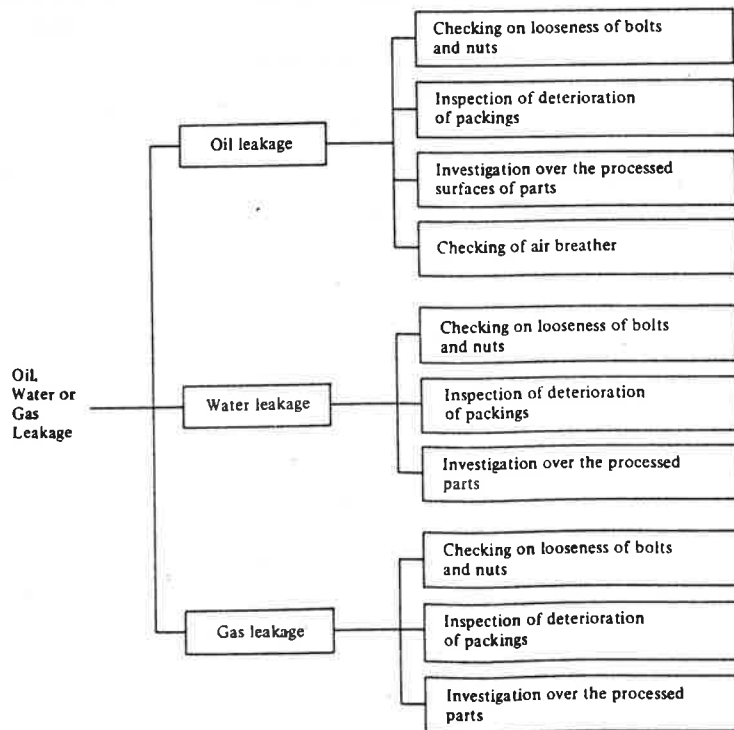

Treatment and Instruction

No.	Cause	Treatment	Instruction to Engine Operator
1	<p>Oil Leakage.</p> <p>1) Loose, expanded or broken bolts and nuts.</p> <p>2) No, damaged or deteriorated packings.</p> <p>3) Hammer marks on processed surface and damaged surfaces.</p> <p>4) Wear and scratched lip of oil seal.</p> <p>5) Dirt adhesion on air breather and damaged air breather.</p> <p>6) Missing of blind plug.</p> <p>7) Pocket found.</p>	<p>1) Retightening or replacement.</p> <p>2) Inserting or replacement of packings.</p> <p>3) Correction or replacement.</p> <p>4) Replacement.</p> <p>5) Cleaning or replacement.</p> <p>6) Attaching.</p> <p>7) Replacement of blind plug.</p>	<p>1) Periodical retightening. Adjusting of tightness.</p> <p>4) Handling of oil seal.</p> <p>5) Maintenance method.</p>
2	<p>Water leakage.</p> <p>1) Loose, expanded or broken bolts and nuts.</p> <p>2) No, damaged or deteriorated packings.</p> <p>3) Hammer marks on processed surfaces and damaged or deformed processed surfaces.</p> <p>4) Pocket found.</p>	<p>1) Retightening or replacement.</p> <p>2) Inserting or replacement of packings.</p> <p>3) Correction or replacement.</p> <p>4) Replacement.</p>	<p>1) Periodical retightening. Adjustment of tightness.</p>
3	<p>Gas leakage.</p> <p>1) Loose, expanded or broken bolts and nuts.</p> <p>2) No, damaged or deteriorated packings.</p> <p>3) Hammer marks on processed surfaces and damaged or deformed processed surfaces.</p>	<p>1) Retightening or replacement.</p> <p>2) Inserting or replacement of packings.</p> <p>3) Correction or replacement.</p>	<p>1) Periodical retightening. Adjustment of tightness.</p>

The following causes may be considered in connection with oil, water or gas leakage:

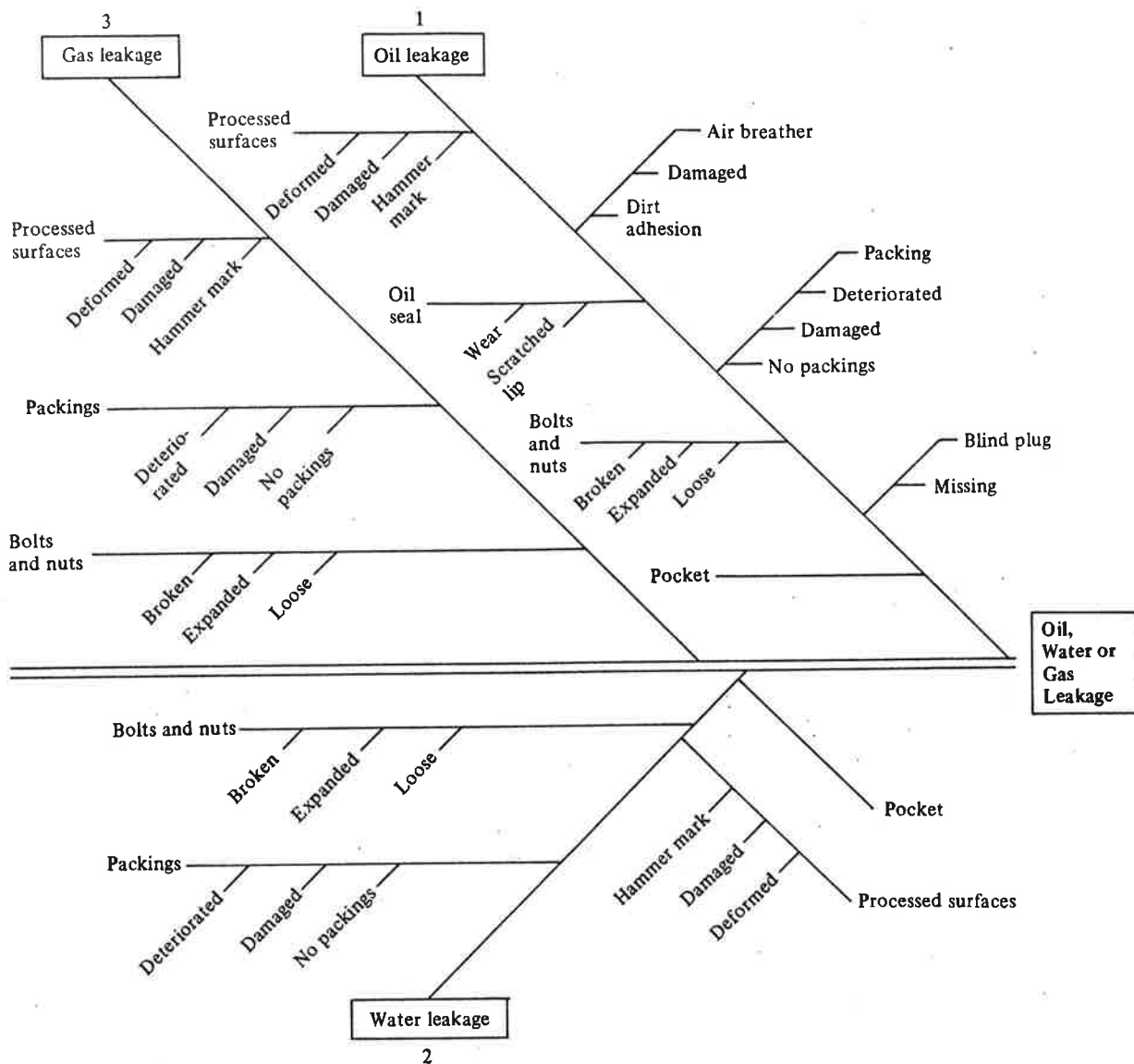

## 7. STORAGE OF ENGINE

1. If the engine is being used in different places, after each usage store the engine at a place as dry and little humid as possible.
2. After stopping the engine operation, close completely both suction and exhaust valves. That is, as described in the section entitled "Adjustment of Valve Clearance," keep the valve at the top dead center of compression stroke.
3. Clean the exterior of engine, and place a cover over the engine if stored outdoor.

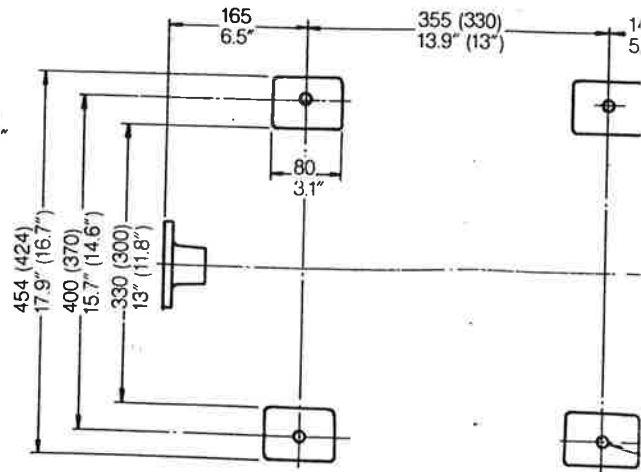
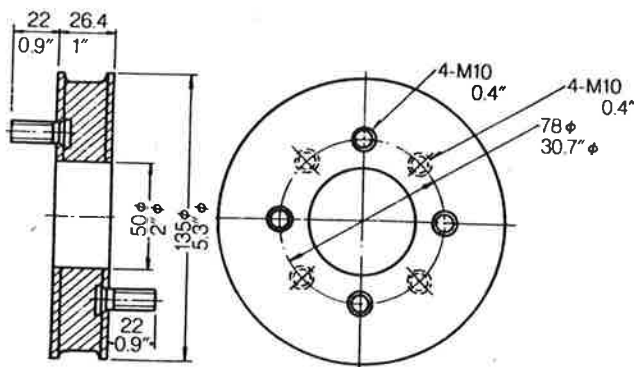
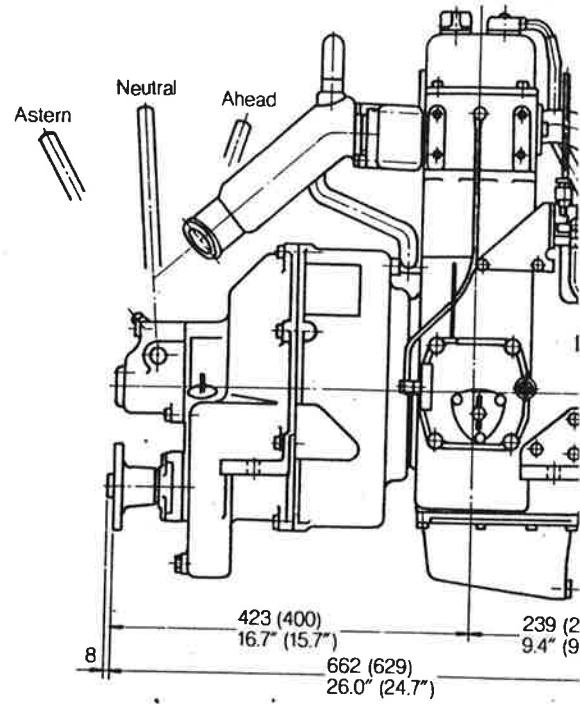
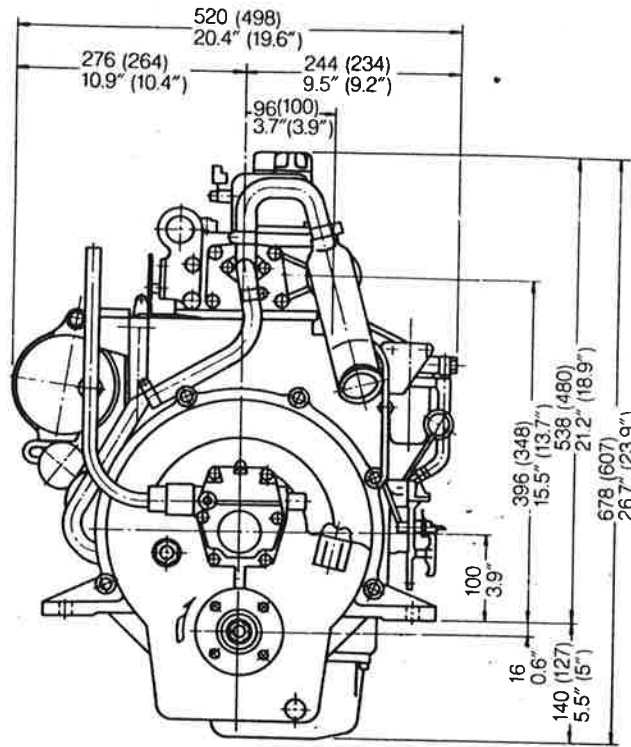

Detail of flexible coupling (Optional)

Detail of engine mount

(Unit=mm) Note: Figures in parentheses = Model SVE8(G) only

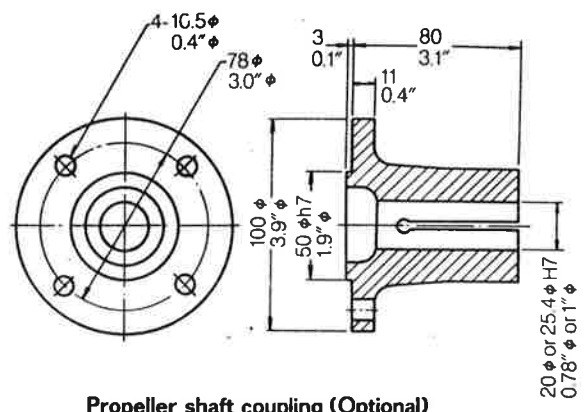
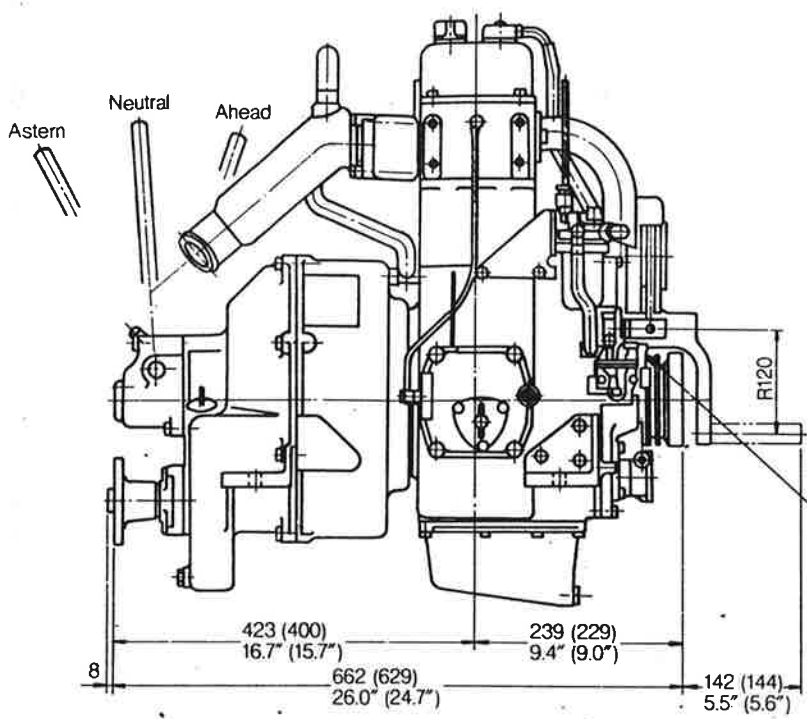

Propeller shaft coupling (Optional)

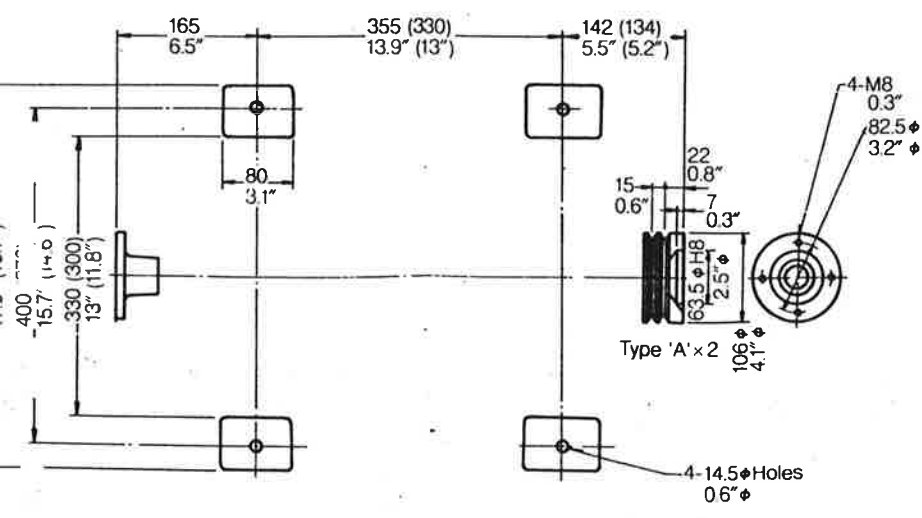
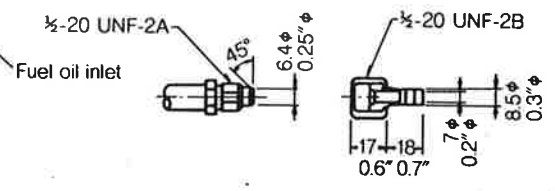

Detail of engine mount

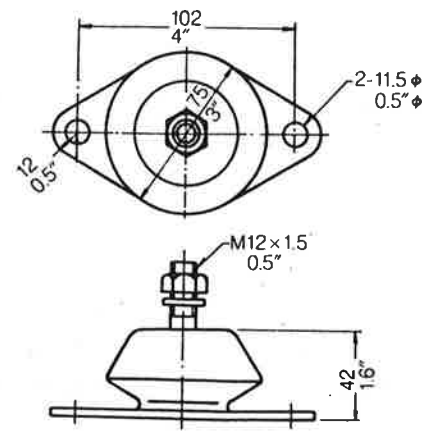

Detail of flexible mounting (Optional)