

Evolution

Wheel drive autopilot

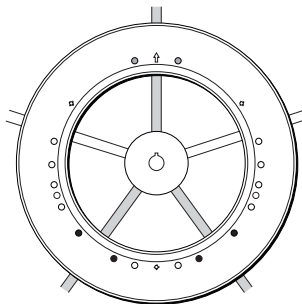

Installation Instructions

English

Date: 05-2017

Document number: 87287-2

© 2017 Raymarine UK Limited

Important Information

This handbook contains important information about installing, using and maintaining your new Raymarine product. To get the best from the product, please read this handbook thoroughly.

Warranty

To register your new Raymarine product, please take a few minutes to register on the website at www.raymarine.com/warranty

Safety notices

WARNING: Product installation

This equipment must be installed and operated in accordance with the instructions contained in this handbook. Failure to do so could result in poor product performance, personal injury and/or damage to your boat.

WARNING: Electrical safety

Make sure the power supply is switched off before you make any electrical connections.

WARNING: Calibration

We supply this product calibrated to default settings that should provide stable performance for most boats. To ensure optimum performance on your boat, you must complete the procedures detailed in the Commissioning section of the handbook for the relevant Autopilot controller.

WARNING: Navigation aid

Although we have designed this product to be accurate and reliable, many factors can affect its performance. As a result, it should only be used as an aid to navigation and should never replace common sense and navigational judgement. Always maintain a permanent watch so you can respond to situations as they develop.

Your Raymarine autopilot will add a new dimension to your boating enjoyment. However, it is the skipper's responsibility to ensure the safety of the boat at all times by following these basic rules:

- Ensure that someone is present at the helm AT ALL TIMES, to take manual control in an emergency.
- Make sure that all members of crew know how to disengage the autopilot.
- Regularly check for other boats and any obstacles to navigation – no matter how clear the sea may appear, a dangerous situation can develop rapidly.
- Maintain an accurate record of the boat's position by using either a navigation aid or visual bearings.
- Maintain a continuous plot of your boat's position on a current chart. Ensure that the locked autopilot heading will steer the boat clear of all obstacles. Make proper allowance for tidal set – the autopilot cannot.
- Even when your autopilot is locked onto the desired track using a navigation aid, always maintain a log and make regular positional plots. Navigation signals can produce significant errors under some circumstances and the autopilot will not be able to detect these errors.

EMC conformance

All Raymarine equipment and accessories are designed to the best industry standards for use in the recreational marine environment. The design and manufacture of Raymarine equipment and accessories conform to the appropriate Electromagnetic Compatibility (EMC) standards, but correct installation is required to ensure that performance is not compromised.

Handbook information

To the best of our knowledge, the information in this handbook was correct when it went to press. However, Raymarine cannot accept liability for any inaccuracies or omissions it may contain. In addition, our policy of continuous product improvement may change specifications without notice. As a result, Raymarine cannot accept liability for any differences between the product and the handbook.

EMC installation guidelines

All Raymarine equipment and accessories are designed to the best industry standards for use in the recreational marine environment.

Their design and manufacture conforms to the appropriate Electromagnetic Compatibility (EMC) standards, but correct installation is required to ensure that performance is not compromised.

Although every effort has been taken to ensure that they will perform under all conditions, it is important to understand what factors could affect the operation of the product.

The guidelines given here describe the conditions for optimum EMC performance, but it is recognized that it may not be possible to meet all of these conditions in all situations. To ensure the best possible conditions for EMC performance within the constraints imposed by any location, always ensure the maximum separation possible between different items of electrical equipment.

For **optimum** EMC performance, it is recommended that **wherever possible**:

- Raymarine equipment and cables connected to it are:
 - At least 3 ft (1 m) from any equipment transmitting or cables carrying radio signals e.g. VHF radios, cables and antennas. In the case of SSB radios, the distance should be increased to 7 ft (2 m).
 - More than 7 ft (2 m) from the path of a radar beam. A radar beam can normally be assumed to spread 20 degrees above and below the radiating element.
- The equipment is supplied from a separate battery from that used for engine start. Voltage drops below 10 V, and starter motor transients, can cause the equipment to reset. This will not damage the equipment, but may cause the loss of some information and may change the operating mode.
- Raymarine specified cables are used. Cutting and rejoining these cables can compromise EMC performance and must be avoided unless doing so is detailed in the installation manual.
- If a suppression ferrite is attached to a cable, this ferrite should not be removed. If the ferrite needs to be removed during installation it must be reassembled in the same position.

Parts supplied

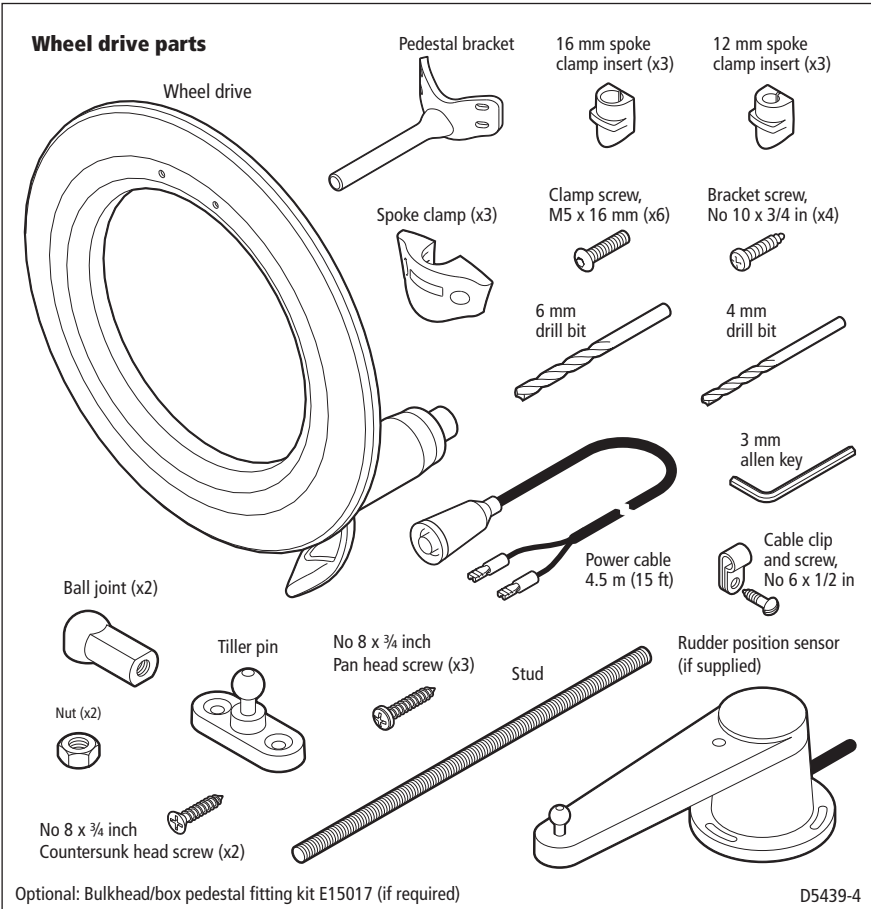

Dimensions

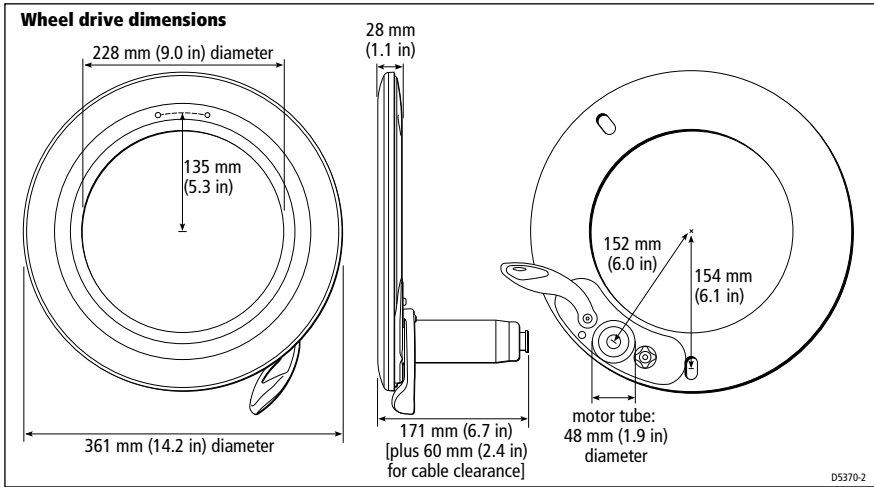

Wheel drive (wheel pilots only)

The Raymarine wheel drive will fit 3, 4, 5, 6, 7 or 8 spoke wheels. It is designed to operate with steering systems with between 1 to 3.5 turns lock to lock.

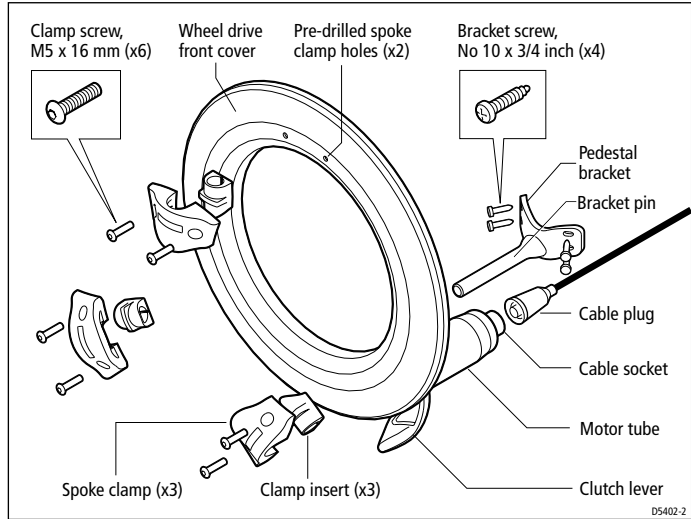

Installation stages

Installing the wheel drive involves four stages:

1. Drilling the spoke clamp holes in the front cover.
2. Securing the wheel drive to the wheel.
3. Attaching the pedestal bracket.
4. Connecting the drive to the control unit.

Drilling the spoke clamp holes

1. Remove the wheel drive front cover:
 - the front cover is held onto the wheel drive by three 'push-fit' posts which sit in three sockets on the drive ring
 - to remove the cover, hold the motor in one hand and use your other hand to pull the cover up and away from the drive unit (as shown below)

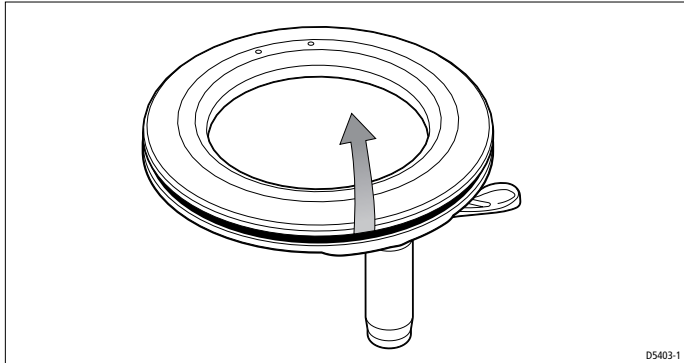

2. Identify the appropriate spoke clamp holes for your wheel. With the arrow at the top, refer to the following diagrams:
 - the holes are numbered inside the cover (e.g. if you have a 5 spoke wheel, you need to drill the 4 locations marked with '5')
 - mark the appropriate spoke clamp holes and check them by holding the cover against your wheel

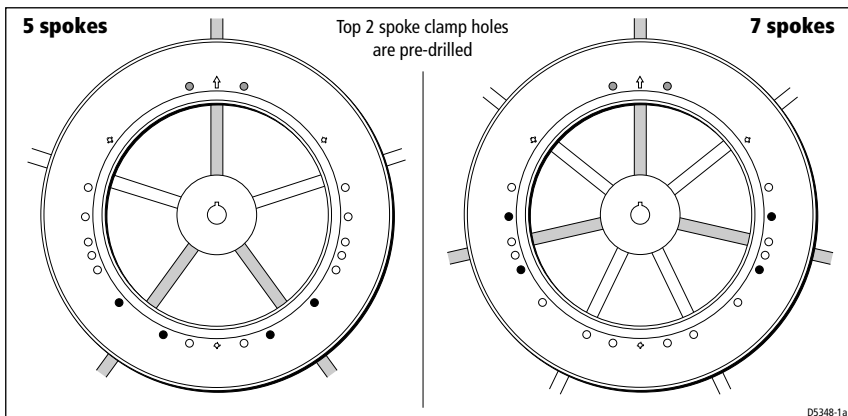

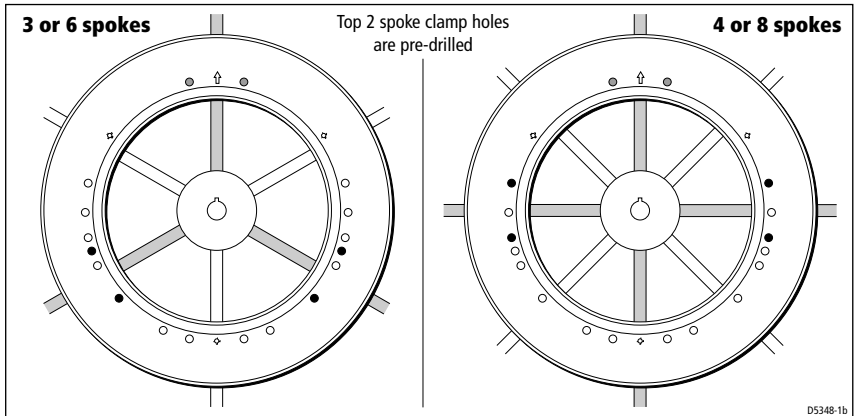

Note: The wheel drive is designed to work with 3 spoke clamps on 4 or 8 spoke wheels. For cosmetic reasons, however, you may want to fit an extra spoke clamp to the fourth spoke. Raymarine dealers can supply an extra spoke clamp (part number A18089).

3. Drill the appropriate spoke clamp holes using the larger of the supplied drill bits (6.0 mm or $\frac{1}{4}$ in):
 - drill from the inside, placing a piece of scrap wood under the cover to produce a clean exit hole
 - you will need to drill 4 new holes so the cover has 6 holes in total (2 for each spoke clamp)

Note: The spoke clamps will cover these exit holes, so they will not be visible when the wheel drive is installed.

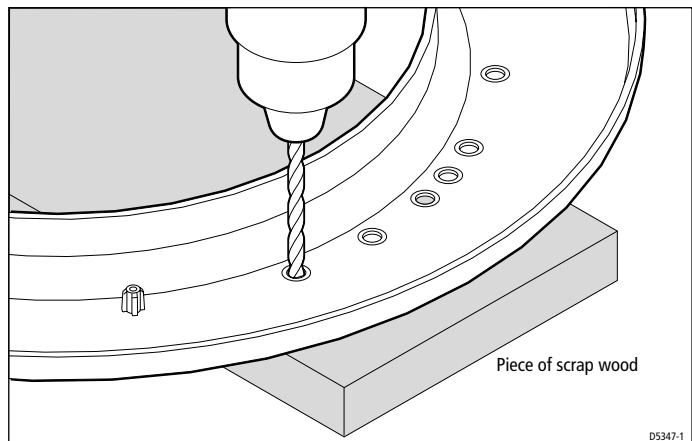

4. Align the cover with the wheel drive:
 - the two pre-drilled holes (marked with an arrow) must line up with their matching pair of threaded inserts on the drive ring (also marked with an arrow)
 - make sure that the other spoke clamp holes align with their threaded inserts

Note: *The cover will only fit back onto the wheel drive when you have aligned the two parts correctly.*

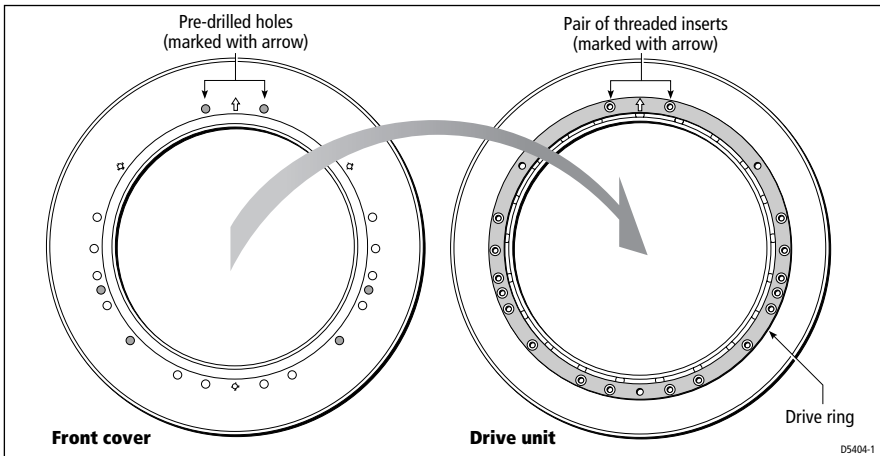

5. Fit the cover back onto the wheel drive:
 - press the cover in the three places shown on the diagram below to push each of the posts back into its locating socket

Note: *This step is easier with the clutch engaged.*

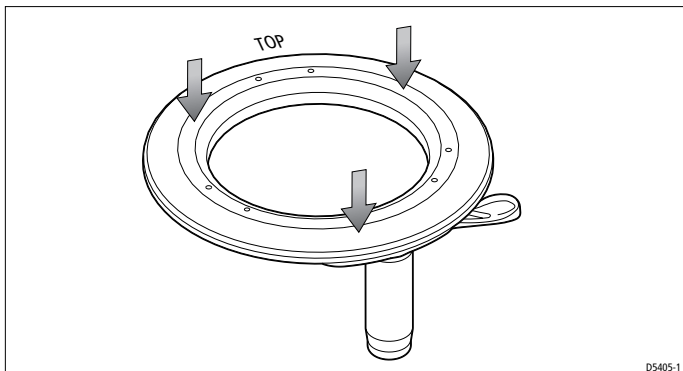

Securing the wheel drive to the wheel

1. Remove the wheel from the pedestal and place it on top of the drive unit, with the front of the wheel and drive both facing up.
2. Using the wheel drive template at the end of this book, select the correct set of spoke clamp inserts for your wheel:
 - measure the spoke diameter at a distance of about 135 mm (5.3 in) from the center of the wheel
 - select the appropriate set of inserts: the wheel drive is supplied with 2 sets of 3 inserts suitable for 12 mm ($\frac{1}{2}$ in) and 16 mm ($\frac{5}{8}$ in) diameter spokes – each insert is marked with its size
3. Fit the first spoke clamp:
 - lubricate the spoke with washing-up liquid – so you can slide the spoke clamp along the spoke to adjust its position
 - place the insert on the spoke about 135 mm (5.3 in) from the wheel center – this distance is not critical as the wheel drive will self-center as you fit all 3 spoke clamps
 - place the spoke clamp onto the insert, making sure that you have correctly located the clamp insert in the clamp
 - locate 2 of the clamp screws (M5 x 16 mm allen-head screws)
 - **lightly** tighten the screws using the 3 mm allen key (supplied)

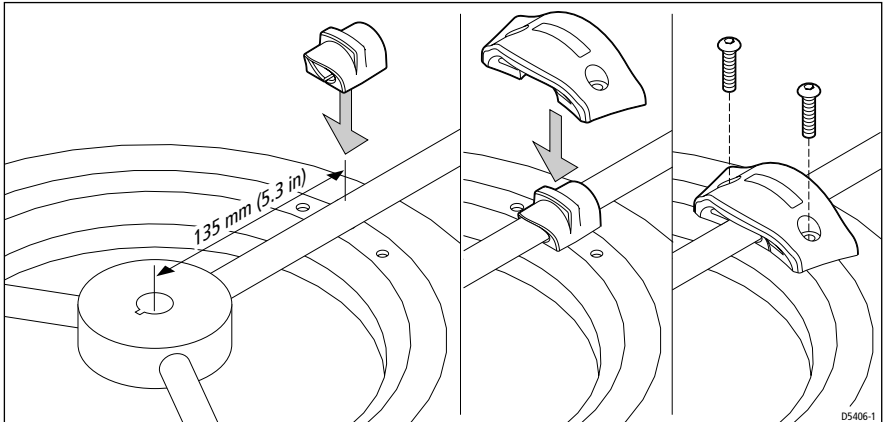

4. Repeat step 3 to fit the other 2 spoke clamps. As you fit each one, adjust the position of the wheel relative to the wheel drive so the holes in the clamp line up with the holes in the cover. **As you do this, the wheel drive will self-center on the wheel.**
5. After fitting all 3 spoke clamps, **fully tighten** the screws.

Attaching the pedestal bracket

Note: If your wheel is bulkhead or box pedestal mounted, you will need to obtain a bulkhead fitting kit (part number E15017) from your Raymarine dealer. Fitting instructions are supplied with the kit.

Motor tube location

Depending on the design of your pedestal and any surrounding obstructions, you can mount the wheel drive in one of two ways:

- **Slot 1 installation:** the standard position uses slot 1 on the back of the wheel drive (the slot closest to the motor tube) so the motor tube is at the bottom to the right of the pedestal
- **Slot 2 installation:** the alternative installation uses slot 2 to position the motor tube at the top to the left of the pedestal

Select the appropriate slot so the motor tube is clear of obstructions.

CAUTION:

If you use slot 2 and you have a pedestal-mounted compass, the drive motor may affect compass readings.

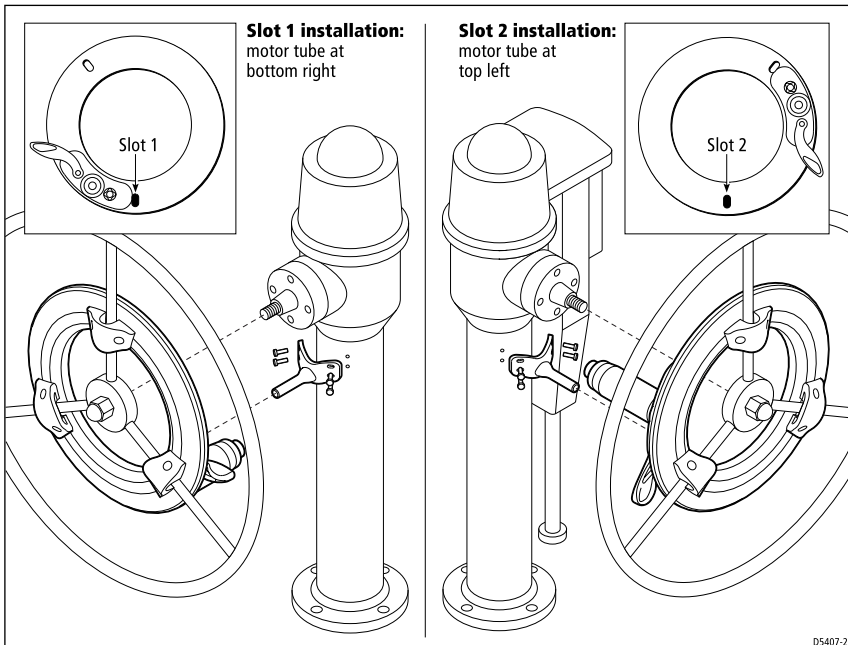

Pedestal bracket – length and position

Note: *If you are replacing an existing wheel drive, you need to: remove the old pedestal bracket, cut the new bracket pin to the correct length (see steps 2 and 3 below), then secure it in the standard orientation using the existing pedestal holes.*

1. Fit the wheel onto the pedestal, tighten the wheel nut to hold the wheel in place, and engage the wheel drive's clutch:
 - if possible, lock the wheel in position with the appropriate slot centered at the bottom of the wheel
 - otherwise, you will find it useful to have an assistant to hold the wheel in position so you can locate the bracket correctly
2. Measure dimension A – the distance between the front of the pedestal and the rear edge of the drive's front cover (see diagram):
 - you may find it easiest to hold the bracket below the wheel drive and mark dimension A directly on the pin

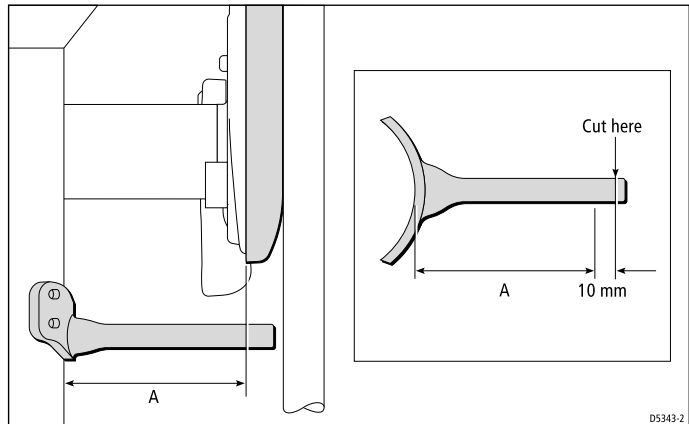

Note: *If the wheel is bent or not running true, dimension A will change with the wheel position. Measure the **smallest** distance.*

3. Use a hacksaw to cut the pin **10 mm (0.4 in) LONGER** than dimension A. Remove any sharp edges at the cut end with sandpaper or a file.
4. Place the pin end in slot 1 or 2 (as required):
 - to do this you may need to loosen the wheel nut so you can slide the wheel forward slightly, place the pin end in the slot, return the wheel to its normal position and re-tighten the wheel nut

Note: You can install the pedestal bracket either way up. In the standard orientation the pin is at the bottom (below the mounting holes – see diagram). If obstructions on the pedestal prevent you from using the standard orientation, you can install the bracket so the pin is at the top (above the mounting holes).

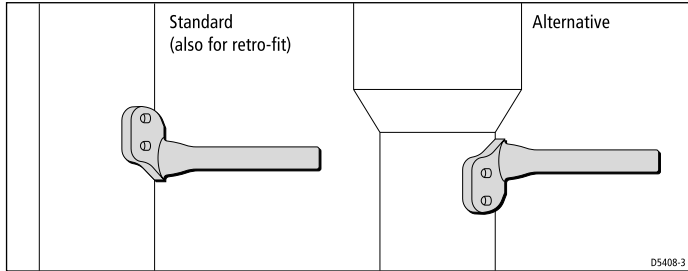

5. Making sure the slot is central at the bottom of the drive unit (6 o'clock position) and the pin is in the **middle** of the slot, carefully draw around the bracket.

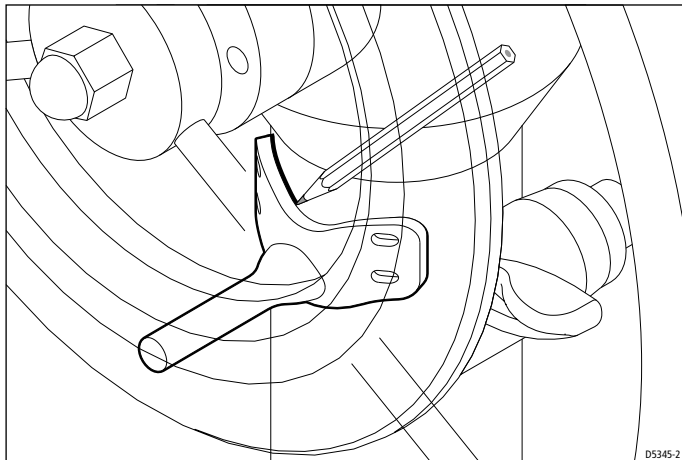

6. Remove the wheel, then hold the bracket on the pedestal in the location you have marked.
7. Check the position and alignment of the pedestal bracket:
 - the bracket pin should be 154 mm (6.1 in) below the pedestal spindle (see the following diagram)
 - the bracket pin should be aligned so it is directly below the pedestal spindle (see the following diagram)

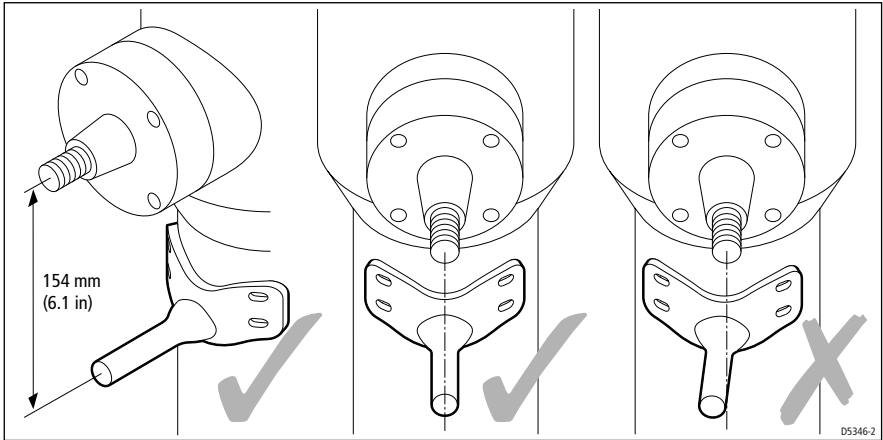

8. When the pedestal bracket is correctly positioned and aligned, mark around the inside of the slots, then remove the bracket.
9. Use a center-punch to mark the center of each slot, then use the smaller supplied drill bit to drill a 4.0 mm ($\frac{5}{32}$ in) diameter hole.

Note: Drill at right angles to the pedestal surface.

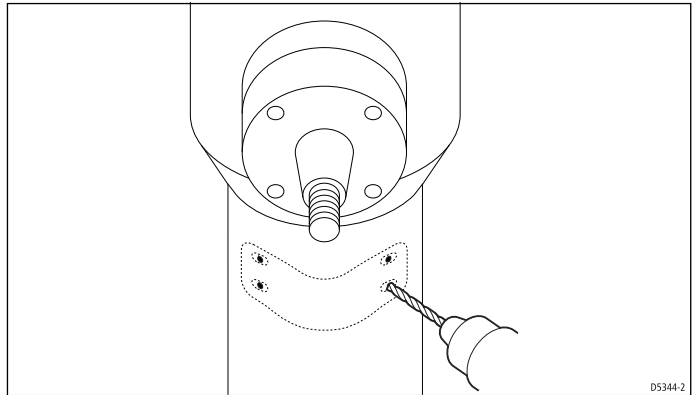

10. Hold the bracket in place then **lightly** tighten the four cross-head screws (No 10 x $\frac{3}{4}$ in). As you do this, make sure the bracket is correctly aligned.
11. Replace the wheel, making sure that you locate the pin in the correct slot (slot 1 or slot 2).
12. Turn the wheel with the clutch off to check that the bracket is correctly positioned and aligned.

Note: *If the wheel is bent or the wheel drive is off center, the pin will move up and down in the back plate slot. As long as the pin does not hit the top or bottom of the slot, this pin movement will not affect the drive unit's performance.*

13. When you have checked alignment, **fully** tighten all four screws.

Connecting to the control unit (ACU)

When you have attached the pedestal bracket, you need to connect the wheel drive to the control unit. The drive unit is supplied with 4.5 m (15 ft) of 2-core cable with a waterproof socket at one end.

1. Connect the socket to the plug on the wheel drive's motor tube:
 - remove the socket cover
 - pull back the plug cover
 - align the locking ring, plug and socket as shown below

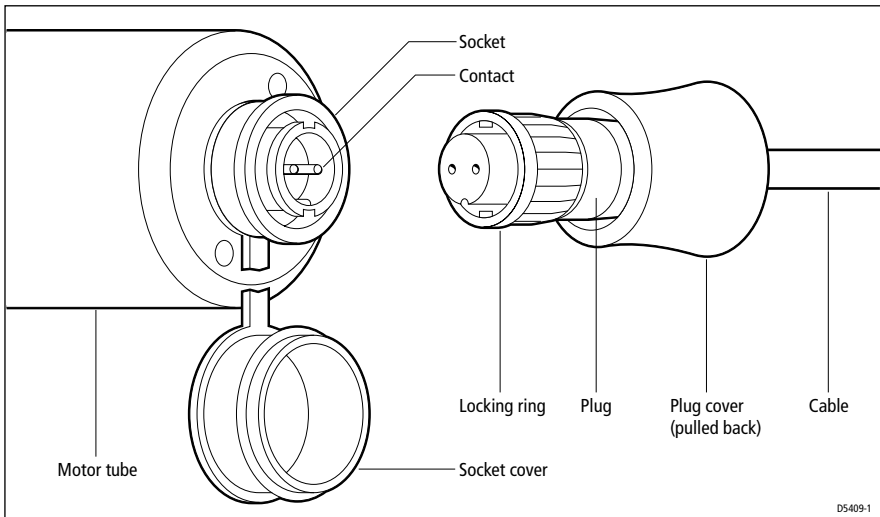

- push the plug firmly into the socket
- turn the locking ring 90° clockwise
- make the connection waterproof by pulling the plug cover across so it protects the plug and socket

Note: *To remove the plug, pull back the cover and turn the locking ring 90° anti-clockwise. If you disconnect the socket for any reason, always use the attached rubber cover to protect the socket.*

2. Route the cable through the pedestal (or guard rail) and back to the control unit:
 - if the pedestal has a cable duct, use this for the drive cable to make sure that it cannot foul the steering mechanism

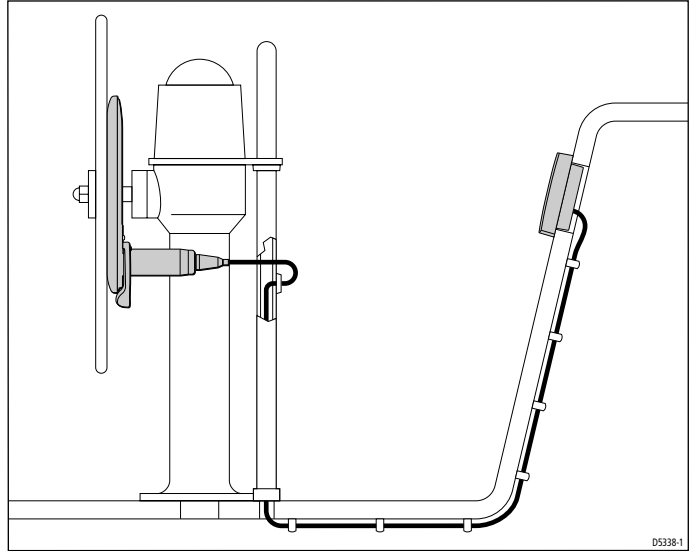

3. Run the drive cable back to the control unit and connect the two cores to the **Drive** terminals as shown.

ACU (control unit) connection

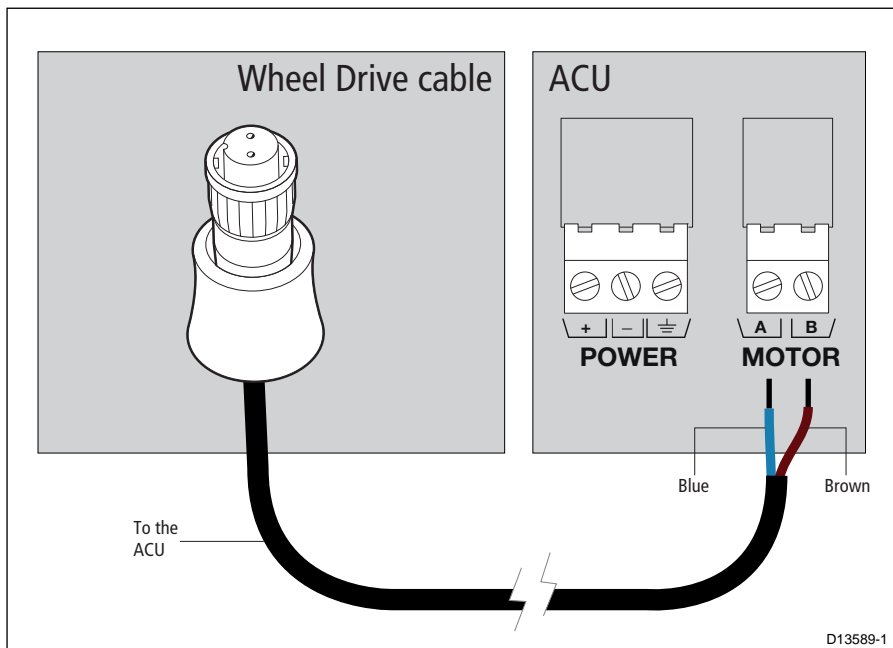

NOTE: You can use the autopilot control head to change the Motor phase:
MENU > Setup > Autopilot Calibration > Drive Settings > Motor Phasing

Rudder position sensor (wheel pilot)

NOTE: Not all systems are supplied with a rudder sensor. It is available separately as part number M81105.

The rudder position sensor connects directly to the boat's tiller arm or quadrant. Installing the sensor involves five main steps:

- ensuring correct alignment
- securing the sensor to the boat
- attaching the sensor to the tiller arm
- checking alignment
- connecting to the control unit

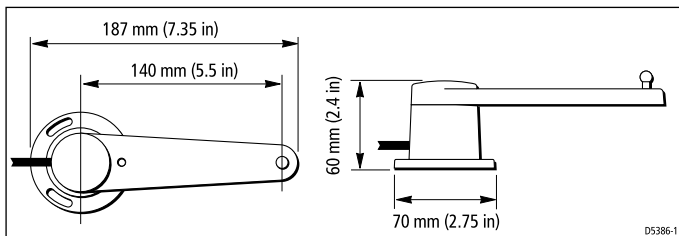

Ensuring correct alignment

CAUTION:

Take care to ensure correct rudder sensor alignment. If the sensor is not correctly aligned, the autopilot system will not perform accurately.

Vertical alignment

When viewed from the front (as shown in the illustration below), the connecting rod should be as level as possible, so the ball-joints at each end are level. It should also remain parallel to the tiller arm's plane of rotation at all times.

Note: *If misalignment exceeds $\pm 5^\circ$ the ball-joints will bind or fail.*

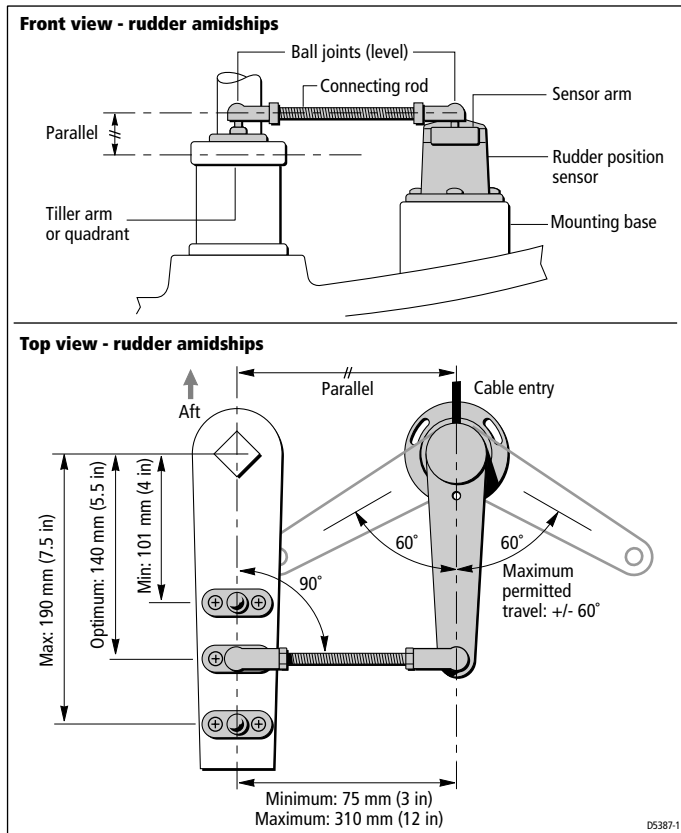

Horizontal alignment

When viewed from above (as shown in the illustration above):

- the sensor arm must be between 75 mm (3 in) and 310 mm (12 in) from the tiller arm
- with the rudder amidships, the sensor arm should be at 90° to the connecting rod and directly opposite the cable entry point on the sensor body
- when the rudder moves from hardover to hardover:
 - the sensor arm and the tiller arm must remain parallel to each other at all times
 - sensor arm movement must not exceed +/- 60°: if the steering system drives the sensor arm beyond these limits it will damage the rudder position sensor

Securing the sensor to the boat

Location

Mount the rudder position sensor on a suitable base alongside the rudder stock and tiller arm.

Note: *If necessary, you can install the sensor upside down. If you mount the sensor in this way, you must swap the red and green cable connections at the control unit.*

Securing the rudder position sensor

1. Hold the sensor in place, mark the mounting holes, then remove the sensor (if required, use the template supplied).
2. Drill the pilot holes using a 3 mm ($\frac{1}{8}$ in) drill bit.
3. Attach the sensor to the mounting base using the three self-tapping screws supplied (pan-head No 8 x $\frac{3}{4}$ inch).

Note: *To make **minor** adjustments to the sensor alignment, loosen the screws, rotate the sensor body, then re-tighten the screws.*

Attaching the sensor to the tiller arm

Attaching the tiller pin to the tiller arm

1. For optimum performance, mount the tiller pin on the tiller arm 140 mm (5.5 in) from the rudder stock center line.

Note: *If necessary, you can fit the tiller pin anywhere between 101 mm (4 in) and 190 mm (7.5 in) from the rudder stock. This will not affect autopilot performance, but will slightly alter the scaling of the rudder angle display shown on the control unit.*

2. Hold the tiller pin in place (either along or across the tiller arm), mark the mounting holes then remove the tiller pin.
3. Drill pilot holes using a 3 mm ($\frac{1}{8}$ in) drill bit.
4. Attach the tiller pin to the tiller arm using the two self-tapping screws supplied (countersunk No 8 x $\frac{3}{4}$ inch) or suitable bolts, nuts and lock washers.

Attaching the connector rod

1. Use a hacksaw to cut the threaded connector rod to length.
2. Screw the lock nuts onto the rod and then the ball-pin sockets.
3. Press the sockets onto the pins on the sensor arm and tiller pin.

Note: *To give the precise rudder position, the rudder sensor has a built-in spring to remove any free play in the linkage to the tiller.*

Checking alignment

Move the rudder from hardover to hardover and check that at all rudder angles:

- all moving parts of the sensor remain free from any obstructions
- the sensor and connecting rod remain accurately aligned
- the ball joints do not bind

Connecting to the control unit (ACU)

1. The rudder position sensor is supplied with 10 m (32 ft) of cable. Route the cable to the control unit, taking into account the EMC installation guidelines
2. Connect the four cores of the cable (color for color) to the **Rudder** terminals on the control unit.

Setting-up the system

When you have installed the system, you need to check that the system is wired correctly and set up to suit your type of boat.

This chapter provide instructions for the following post-installation procedures:

Functional test

Switch on

1. When you have installed your autopilot system, switch on the main power breaker.
2. If the control unit is active and the system operating, the control unit will beep and display the pilot type (Wheel or Tiller).

CAUTION: Wheel drive systems

One second after power-on the wheel pilot will drive to starboard for three seconds. This is to allow even wear on the drive belt.

3. After displaying the pilot type for two seconds, the control unit will then display the Standby screen.



Autopilot steering direction

The autopilot steering direction defines which way the autopilot applies helm when you press a course change key or when the boat goes off course.

Check the autopilot steering direction as follows:

1. **Wheel Pilot:** Engage the wheel drive clutch by rotating the clutch lever clockwise so it engages fully onto the locating pip.

WARNING: Wheel drive clutch

Always reach AROUND (not through) the wheel to operate the wheel drive clutch lever.

Wheel pilot

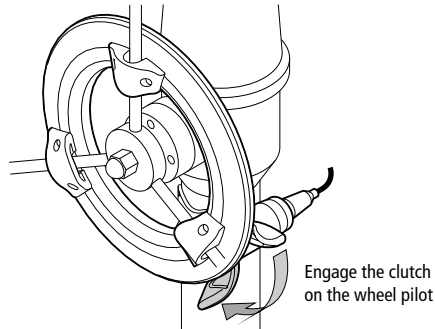

2. Press the **+10** key. The helm should move to produce a turn to starboard.

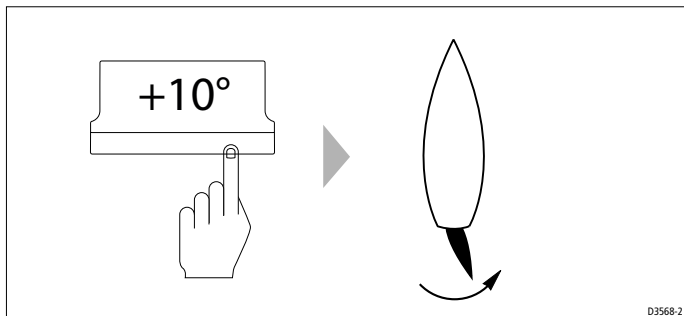

3. If the helm produces a turn to port, reverse the drive connections on the back of the control unit.

6.2 Check rudder sensor operation (if fitted)

Note: *This procedure is only required if you have fitted a rudder position sensor to a wheel pilot system.*

If you have fitted a rudder position sensor to a wheel pilot, before commencing the initial sea trial you must make sure that it senses rudder movement in the correct way and is aligned with the rudder:

1. Press the **-10** or **+10** key to move the helm to check that the rudder bar display moves in the same direction as the sensor arm:
 - if the display moves in the opposite direction, swap the red and green cables at the control unit (see *page 75*)
2. When you have done this, use the **-1**, **+1**, **-10** and **+10** keys to move the helm to its center position.
3. Check the rudder bar display – the rudder angle should be within $\pm 7^\circ$ of center.

If necessary, bring the rudder angle to within $\pm 7^\circ$ of the center by

- loosening the mounting bolts on the rudder position sensor
 - rotating the base of the sensor until the reported rudder angle is as close to zero as possible
 - re-tightening the bolts
4. When the offset is less than $\pm 7^\circ$, use the rudder alignment (ALIGN RUD) setting in Dealer setup (see *page 98*) to accurately align the display and helm.

Note: *You cannot use the rudder alignment (ALIGN RUD) setting to correct an offset of more than $\pm 7^\circ$.*

5. Calibrate the rudder limits using the rudder limit (RUD LIMIT) setting in Dealer setup:
 - manually set the rudder to each end stop (port and starboard): for each direction, use the rudder bar on the display to determine the end-stop angle
 - access the rudder limit screen (RUD LIMIT)
 - set the autopilot rudder limit so that it is 5° less than the smallest (port or starboard) mechanical end stop angle

Initial sea trial

When you have checked that the system is functioning correctly, you must complete the setup by taking the boat on a short sea trial to:

- correct the compass deviation
- adjust the heading alignment
- check autopilot operation
- adjust the rudder gain

Note: Refer to your pilot controller instructions for important setup and commissioning procedures.

The system has built-in calibration so you can fine tune it to suit your boat, its steering system and its dynamic steering characteristics. So you can perform the initial sea trial, we calibrate the unit at the factory to provide safe and stable autopilot control for the majority of boats.

You should perform the initial sea trial:

- when you have successfully completed all of the installation, functional tests and rudder sensor checks
- before making any other changes to default calibration settings.
- in conditions of light wind and calm water, so you can assess autopilot performance without the influence of strong winds or large waves
- in waters that are clear of any obstructions

Note: You can return to hand steering at any time during the sea trial by disengaging the wheel drive clutch, or removing the tiller drive pushrod from the tiller pin.

EMC conformance

Always check the installation before going to sea to make sure that it is not affected by radio transmissions, engine starting etc.

2.2 Using Auto mode

Engaging the autopilot (Auto mode)

1. Steady the boat on the required heading.
2. **Wheel Pilot:** Engage the wheel drive clutch by rotating the clutch lever clockwise (so the lever **engages fully** onto the locating pip).

WARNING: Wheel drive clutch

Always reach **AROUND** (not through) the wheel to operate the wheel drive clutch lever.

Wheel pilot

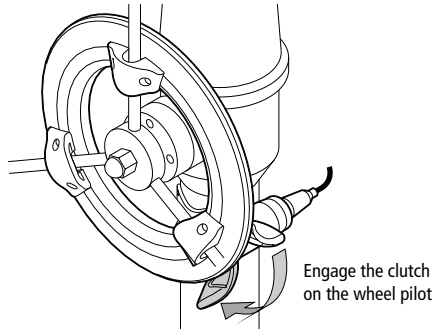

3. Press **auto**:
 - in Auto mode, the display shows the locked autopilot heading

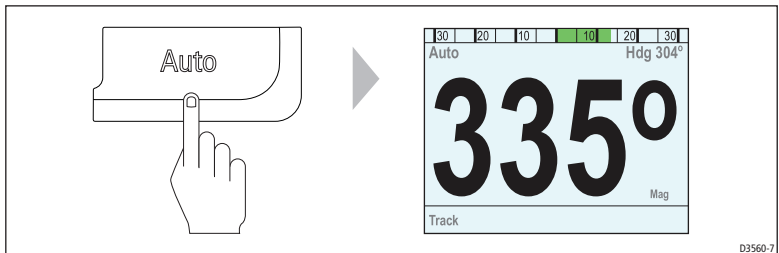

CAUTION:

Autopilot course control makes it easier to sail a boat, but it is **NOT** a substitute for good seamanship. **ALWAYS** maintain a permanent watch, no matter how clear the sea appears to be.

Disengaging the autopilot (Standby mode)

1. Press **standby**.
 - The display shows the boat's current compass heading.

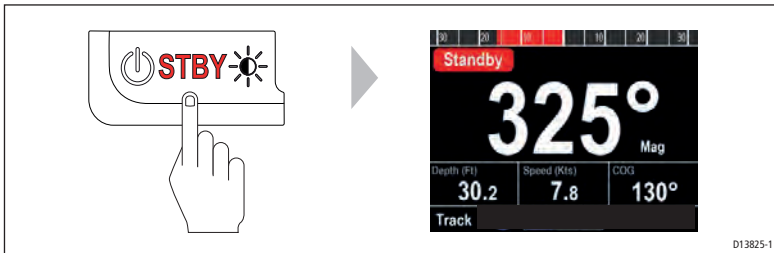

2. Disengage the autopilot to return to hand steering:
 - **Wheel Pilot:** Disengage the wheel drive clutch by rotating the clutch lever anti-clockwise (so the lever **engages fully** onto the locating pip).

CAUTION: Wheel drive systems

On wheel drive systems, always make sure that the clutch is **FULLY DISENGAGED** before you leave the boat.

Maintenance & Fault Finding

This chapter provides information about identifying common problems, maintaining your autopilot system and obtaining product support:

Fault finding

All Raymarine products are designed to provide many years of trouble-free operation. We also put them through comprehensive testing and quality assurance procedures before shipping.

In the unlikely event that a fault does occur with your autopilot, use the following table to help identify the problem and provide a solution.

| SYMPTOM | SOLUTION |
|--|--|
| The control unit display is blank | No power – check the fuse/circuit breaker. |
| The displayed compass heading does not agree with the boat's compass | You have not corrected the compass for deviation – carry out the deviation and alignment procedures |
| Boat turns slowly and takes a long time to come onto course | Rudder gain too low |
| Boat overshoots when turning onto a new course | Rudder gain too high |
| The autopilot appears to be unstable in Track mode, or track-holding is slow | If tide speed exceeds 35% of boat speed, and boat speed is not available via SeaTalk, change the Cruise Speed setting in Dealer Setup to the boat's cruising speed |
| The autopilot appears to be unstable on Northerly headings in the Northern hemisphere and Southerly headings in the Southern hemisphere | Northerly/Southerly heading correction (AutoAdapt) is not set up |
| Display shows CAL LOCK when entering calibration | Calibration lock is on – turn off the calibration protection feature in Dealer setup |

| SYMPTOM | SOLUTION |
|--|--|
| The autopilot will not 'talk' to other SeaTalk instruments | Cabling problem – make sure all the cables are connected properly. |
| Position information not received | Navigator not transmitting the correct position data. |
| The autopilot will not auto advance to the next waypoint | No bearing to waypoint information received from the navigator. |
| The control unit display shows a series of rotating dashes | Compass deviation correction is running |
| The control unit display shows a series of stationary dashes | The control unit is not receiving data – check the cabling. |
| The control unit display shows NO DATA | The signals received by the navigator are too weak for reliable navigation – refer to the navigator handbook for further action. OR Wind trim data is not available – check the connection to the wind instrument. |
| Wheel drive: drive belt slips in Auto mode (motor operates but drive does not turn wheel) | Tighten the clutch |
| Wheel drive: drive belt drags in Standby mode | Loosen the clutch |

General maintenance

Wheel drive

Routine maintenance

After each trip, flush inside the drive unit by inserting a hose pipe in the free slot on the back cover.

Cleaning the wheel drive

CAUTION:

Do not use mineral-based solvents (such as WD40) to lubricate or clean the wheel drive as they will damage the material.

We recommend that you complete the following steps each season to prevent the build-up of salt on the wheel drive bearings and drive belt:

1. Remove the wheel drive from the wheel:
 - remove the wheel from the pedestal
 - remove the spoke clamp screws
 - remove the wheel drive front cover
2. Check inside the drive unit for any signs of damage.
3. Thoroughly flush the wheel drive interior with fresh water to remove any salt build-up on the bearings and drive belt.
Do not lubricate any part of the wheel drive. It is designed to run without lubrication.
4. Replace the front cover then fit wheel drive back onto the wheel.
5. Fit the wheel and wheel drive back onto the pedestal.
6. Clean the wheel drive case (using mild detergent if necessary), then flush thoroughly with fresh water.

Adjusting the clutch

You need to adjust the clutch if the drive belt slips in Auto mode or drags in Standby mode. In normal use, you can tell if the clutch is slipping if the motor operates but the drive does not turn the wheel.

To adjust the clutch, first make sure that the autopilot is in Standby mode and the clutch is disengaged. Then:

1. Use a 3 mm allen key (supplied) to loosen the clutch knob screw about 2 turns anti-clockwise.
2. Turn the clutch knob either 4 clicks clockwise to tighten the clutch, or 4 clicks anti-clockwise to loosen the clutch.
3. Use the allen key to re-tighten the clutch knob screw.
4. Check that the wheel still moves freely with the clutch off.

Note: *If the wheel does not move freely, reduce the clutch tension by turning the clutch knob 2 clicks anti-clockwise and check again*

5. Check the drive's operation with the clutch engaged.

This procedure is usually sufficient to correct a slipping or dragging drive belt. In some cases, however, you may need to repeat the steps to adjust the clutch further.

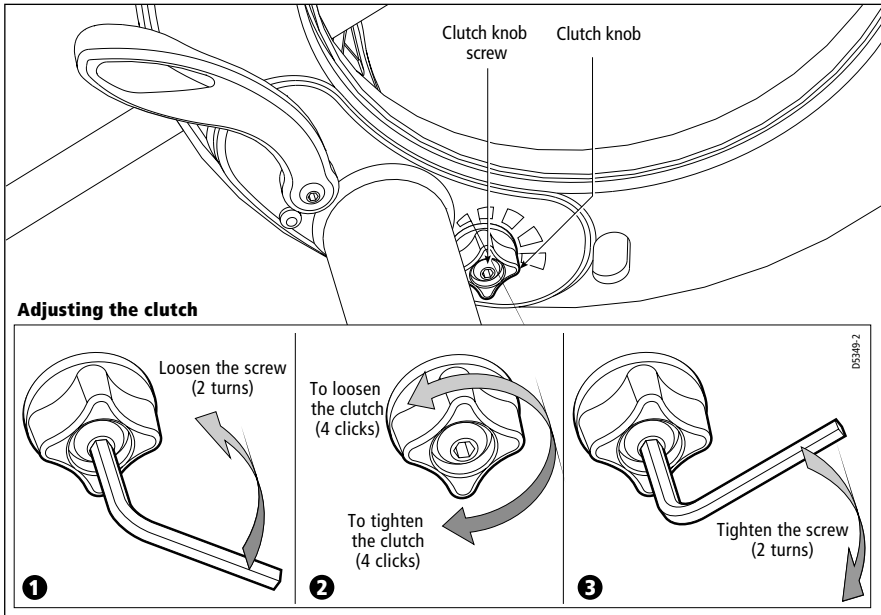

Replacing the belt

The drive belt is designed to be user serviceable. If there is insufficient adjustment to cure a slipping clutch, or if the drive belt is damaged in any way (if it is broken, frayed or stretched), you should replace the drive belt. You can obtain a replacement belt from any Raymarine dealer (part number A18083). Fitting instructions are supplied with the belt.

User serviceable parts

You can obtain the following wheel drive spare parts from your Raymarine dealer:

| Part description | Part number |
|------------------|-------------|
| Front cover | A18074 |
| Clutch lever | A18077 |
| Clutch knob | A18078 |

| Part description | Part number |
|---|--------------------|
| Pedestal bracket (torque restraint) | A18080 |
| Drive belt | A18083 |
| Clutch kit (clutch eccentric and clutch roller) | A18084 |
| Single spoke clamp, screws and inserts | A18089 |

Control unit

Routine checks

The control unit is a sealed unit. As a result, user maintenance is limited to the following routine checks:

- make sure all cable connectors are firmly attached
- examine the cables for signs of wear or damage – replace any damaged cables

Cleaning the display

CAUTION:

Take care when cleaning the display. Do not wipe the display screen with a dry cloth as this could scratch the screen coating. Do not use acid, ammonia based or abrasive products.

- **Never** use chemical or abrasive materials to clean the control unit. If the control unit is dirty, wipe it with a clean, damp cloth.
- In certain conditions, condensation may appear inside the display screen. This will not harm the unit, and you can clear it by switching on the illumination for a short time.

EMC advice

- When powered up, all electrical equipment produces electromagnetic fields. These can cause adjacent pieces of electrical equipment to interact with one another, with a consequent adverse effect on operation.
- To minimize these effects and enable you to get the best possible performance from your Raymarine equipment, guidelines are given in the installation instructions, to enable you to ensure

minimum interaction between different items of equipment, i.e. ensure optimum Electromagnetic Compatibility (EMC).

- Always report any EMC-related problems to your nearest Raymarine dealer. We use such information to improve our quality standards.
- In some installations, it may not be possible to prevent the equipment from being affected by external influences. In general this will not damage the equipment but it can lead to spurious resetting action, or momentarily may result in faulty operation.

4.3 Product support

Raymarine products are supported by a worldwide network of distributors and Authorized Service Representatives. If you encounter any difficulties with this product, please contact either your national distributor, service representative, or the **Raymarine Technical Services Call Center**. Refer to the Raymarine website: www.raymarine.com/support

User notes

User notes

Raymarine[®]
A FLIR COMPANY

www.raymarine.com

CE