

Hunter 49

Boom and Mainsheet Purchase Layout

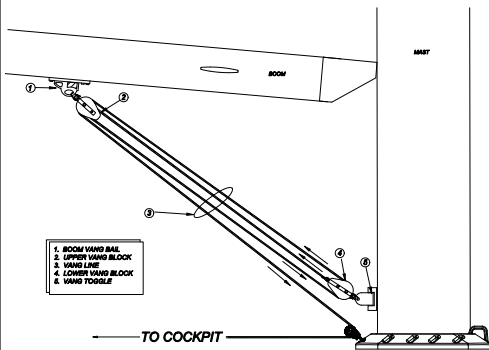

ROPE VANG DETAILS (STANDARD)

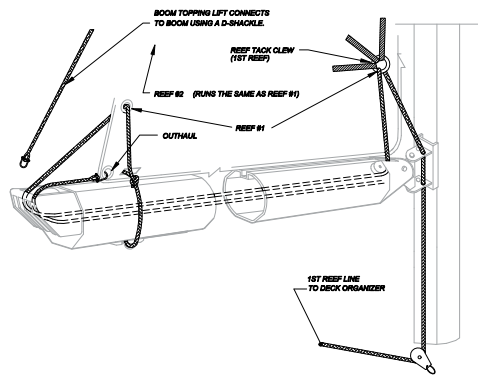

BOOM WITH REEFING LAYOUT

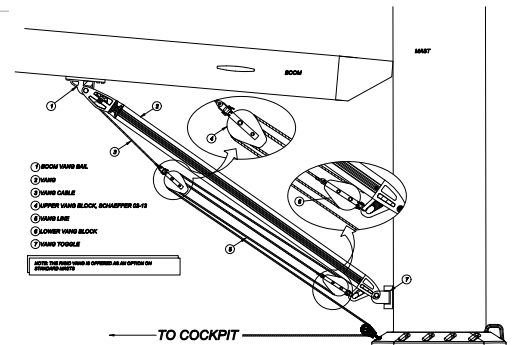

RIGID VANG (FURLING OPTION)

- 1 BLOCK ON TRAVELER CAR
- 2 BOOM BALE AND MAINSHEET BLOCK
- 3 ARCH BLOCK ON BALE TO ARCH UPPER SHEAVE
- 4 MAINSHEET
- 5 MAINSHEET BOOM EXT
- 6 MAINSHEET RUN INSIDE BOOM
- 7 MAINSHEET SHEAVE INSIDE FWD BOOM END
- 8 MAINSHEET BLOCK AT MAST STEP
- 9 MAINSHEET THRU BLOCK ORGANIZERS
- 10 MAINSHEET THROUGH SHEET STOPPER TO WINCH
- 11 ARCH UPPER SHEAVE FOR MAIN SHEET (PORT SIDE)
- 12 MAINSHEET THROUGH SHEET STOPPER AND BLOCK TO WINCH

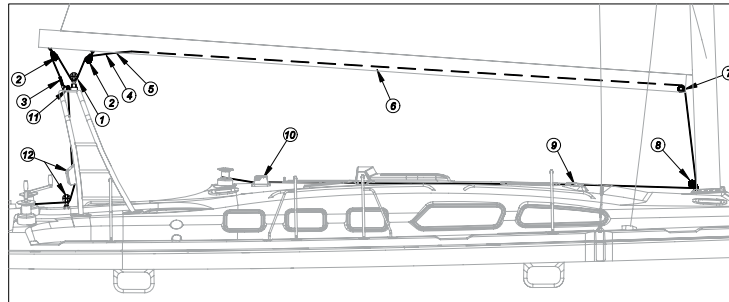

DUAL ENDED MAINSHEET PURCHASE LAYOUT

