

# 1. Cooling System

## 1-1 Composition

Models 2QM20Y(F) and 3QM30Y(F) are constructed from different parts but use the same water flow. The illustration below is of Model 2QM20Y(F).

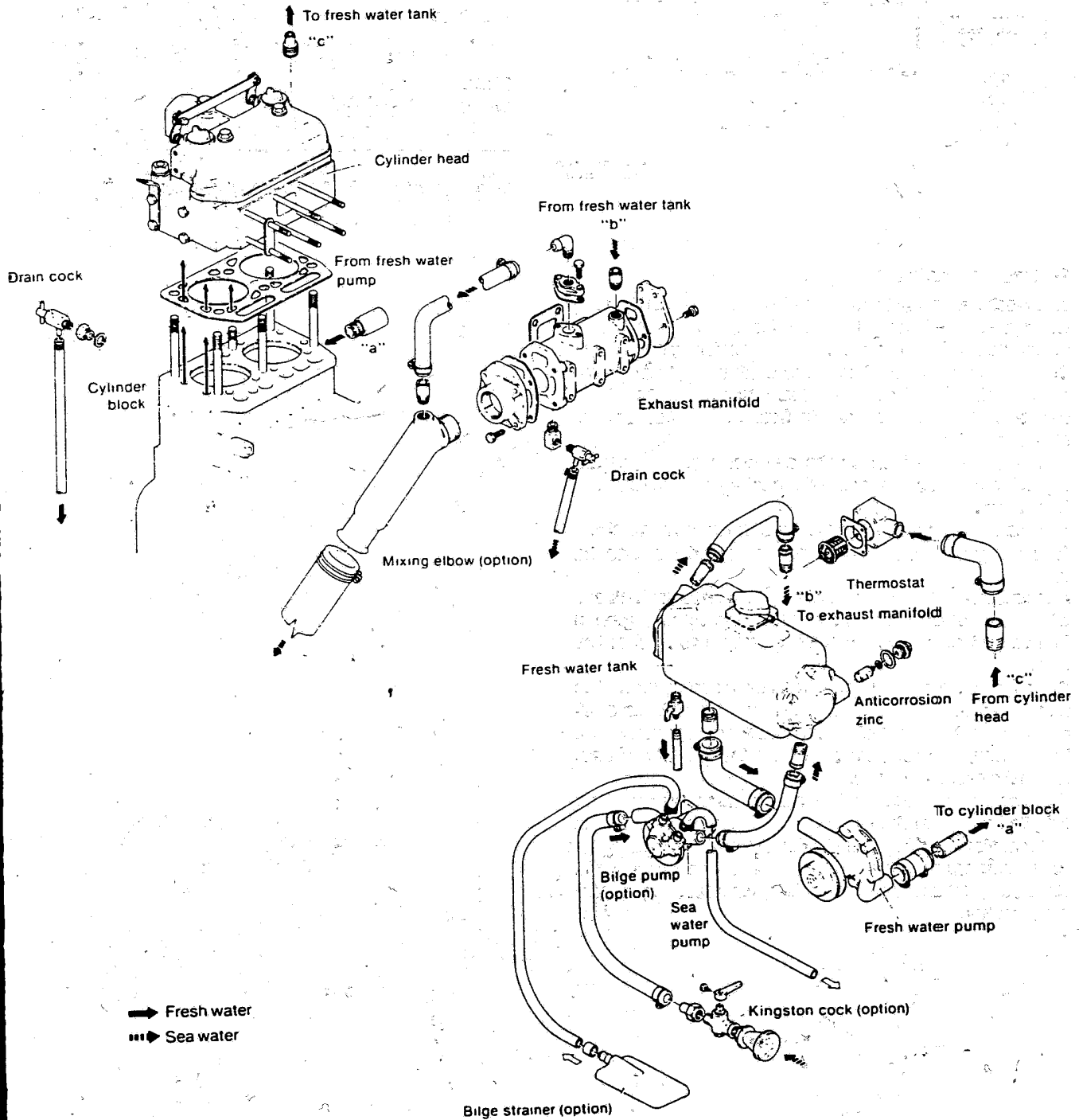

NOTE: On Model 3QM30Y(F), a flanged joint is used on the sea-water side of the exhaust manifold.

1-4 3QM30Y

1-4.1 Intake side viewed from stern

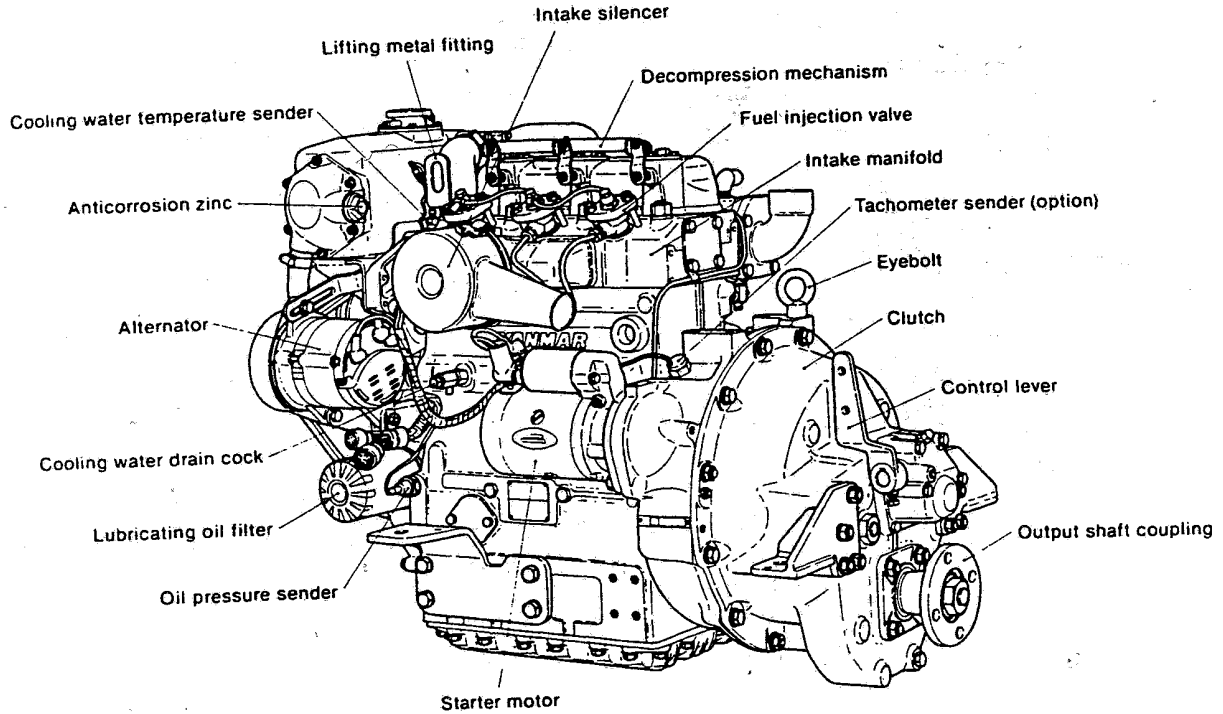

1-4.2 Exhaust side viewed from bow

