

ProMariner®

▶ Visit ProMariner Online at www.promariner.com, for a Complete Selection of Quality Marine Products...

Here are just a few:

- ▶ ProMite Series - Recreational Grade Waterproof Marine Battery Chargers
- ▶ ProSport Series - Heavy Duty Recreational Grade Waterproof Marine Battery Chargers
- ▶ ProTournament Series - Professional Grade Tournament Waterproof Marine Battery Chargers
- ▶ ProNautic C³ Series All Digital Dry Mount Battery Chargers
- ▶ Digital Mobile Charge In-Transit Chargers
- ▶ Battery Maintainers
- ▶ AC Plug Holders
- ▶ Battery Isolators
- ▶ Isolation Transformers
- ▶ Galvanic Isolators and Monitored Systems
- ▶ Corrosion Control Products
- ▶ Waterproof Marine Binoculars
- ▶ Gold Plated Fuses and Holders
- ▶ A Complete Line of Hand Held Test Meters
- ▶ Online Technical Support and Service Support

Visit frequently, we are always adding new products for your boating enjoyment!

Professional Mariner, LLC
200 International Drive, STE 195
Portsmouth, New Hampshire 03801
TEL: 603-433-4440
FAX: 603-433-4442
www.promariner.com

specifications subject to change without notice

UL 03/07 B

ProMariner®

ProTechi Series

Automatic Marine Battery Charger

Owner's Manual and Installation Guide



Advanced Electronic Fully Automatic, 4-Stage On-Board Battery Charger

Models	Part No.	Amperage	No. of Banks	Volts
ProTech1210i	63310	10 Amps	2 Banks	12
ProTech1215i	63315	15 Amps	3 Banks	12
ProTech1220i	63320	20 Amps	3 Banks	12
ProTech1225i	63325	25 Amps	3 Banks	12
ProTech1230iPLUS	63331	30 Amps	3 Banks	12
ProTech1240iPLUS	63341	40 Amps	3 Banks	12
ProTech2420iPLUS	63420	20 Amps	3 Banks	24

IMPORTANT NOTICE

This manual contains important safety and operating instructions for ProTech-i Models: 1210i, 1215i, 1220i, 1225i, 1230iPlus, 1240iPlus and 2420iPlus. Please save and read all safety, operating, and installation instructions before installing or applying AC power to your ProTech-i Series Battery Charger.

Your Satisfaction is Important to Us!

Do not return this product to retailer or dealer for any service or warranty requirements.

Please call our Customer Care Department at 800-824-0524 from 8:30 am to 5 pm Eastern Time for any warranty, service or installation assistance. Thank you - ProMariner Customer Care

PLEASE RECORD YOUR:

Model Number: _____ Serial Number: _____ Date of Purchase: _____

Serial number is located inside the ProTech-i Charger. To view, simply unscrew and slide off the top cover of the DC Power end cap.



► Important Notices - Please read each important notice below and this entire manual before installing your ProTech-i Series Charger.

This manual is written to assist in the installation of the ProTech-i Series On-Board Marine Battery Charger, however because this is a permanent AC and DC hardwired installation, **ProMariner strongly recommends that an ABYC certified marine electrical technician be used for the electrical installation of your new ProTech-i Series charger to insure a safe install that is compliant to ABYC and UL Marine Standards to include but not limited to proper marine grade wire rated for the amperage rating of your charger and the length of wire used or needed.**

All existing electrical hardware i.e. battery switches, distribution blocks, fuses, protective breakers for each battery, must be inspected for proper condition, ratings and operation. All connections and wiring must conform to ABYC and UL standards.

To avoid risk of injury, fire, and electrical shock, inspect all new or existing AC and DC wiring associated with your boat's battery charging system for properly rated wire gauge for the amperage rating of the ProTech-i Series Charger you will be installing (See page 11 for wire gauge and Ratings by ProTech-i Series model). **All undersized and substandard non-marine wiring must be replaced before proceeding with your installation and applying power connections to your ProTech-i Series Charger.**

The ProTech-i Series Charger is a dry or weatherproof compartment charger and must be installed with the required protective drip shield included with your charger. Do not expose your ProTech-i Series Charger to rain, snow, fresh or saltwater, wash down water or bilge water.

► Important Notice: FCC Class B Part 15 Notification

Your ProTech-i Series On-Board Marine Battery Charger has been designed and tested to comply to FCC Class B part 15. These regulations are to provide adequate protection against harmful interference while operating in a commercial application. If in a residential setting you are encountering interference with TV and Radio reception then: Simply disconnect AC power from the ProTech-i Series Charger to confirm if your battery charger is causing interference, if so the user can explore the following to minimize interference:

- 1) Choose a different AC circuit to power your On-Board Marine Battery Charger
- 2) Make sure your AC Connections include a proper Ground Connection.
- 3) Reposition the receiving antenna
- 4) Purchase a separate AC Line filter
- 5) Relocate Charger so separation from the receiving equipment is at its furthest point.

World Wide Approvals and Certifications:
 Certified to UL 1236 SB, ULc, Ignition Protected, CE,
 c UL To: CSA C22.2 No. 107.2-01
 FCC Class B, Meets ABYC A-31 requirements



► Customer Service & Warranty

We are committed to customer satisfaction and value your business. If at any time during the warranty period you experience a problem with your ProTech-i Series On-Board Marine Battery Charger call us at 1-800-824-0524 or email info@promariner.com for technical support.

WARRANTY CARD CAN BE REGISTERED AT WWW.PROMARINER.COM
 or the warranty card included in this manual can be completed
 and sent to ProMariner by mail.

PROTECH-I SERIES ON-BOARD MARINE BATTERY CHARGER TWO YEAR WARRANTY WITH A LIMITED LIFETIME REPAIR OR REPLACEMENT POLICY

Each ProMariner ProTech-i Series Model is guaranteed against defects in material and workmanship for two full years after purchase.

Each serial numbered product has an additional repair adjustment provision after the 2 year limited warranty that limits the maximum charge for repair or replacement to 50% of the current list price, plus shipping and handling.

- Warranty and repair adjustment calculated from manufacture date if not registered or proof of purchase within two weeks of sale.
- Warranty void if unauthorized repairs attempted.
- Customer is responsible for shipping to ProMariner.
- Cosmetic repairs are done at the owner's request and expense.

Purchase or other acceptance of the product shall be on the condition and agreement that Professional Mariner, LLC SHALL NOT BE LIABLE FOR INCIDENTAL OR CONSEQUENTIAL DAMAGES OF ANY KIND. (Some states do not allow the exclusion or limitation of incidental or consequential damages, so the above limitations may not apply to you.) This warranty is made in lieu of all other obligations or liabilities on the part of Professional Mariner. Professional Mariner neither assumes nor authorizes any person for any obligation or liability in connection with the sale of this product.

To make a claim under warranty, go to www.promariner.com and click on the support tab and follow the instructions making sure to identify the product and the problem. If you can not use our online warranty claim registration, please feel free to call ProMariner at the toll free number listed below. Professional Mariner will make its best effort to repair or replace the product, if found defective within the terms of the warranty, within 30 days after return of the product to the company. Professional Mariner will ship the repaired or replaced product back to the purchaser.

This warranty gives you specific legal rights, and you may also have other rights, which vary from state to state. This warranty is in lieu of all others expressed or implied.

Factory Service Center & Technical Support
 Professional Mariner, LLC
 200 International Drive, STE 195
 Portsmouth, NH 03801
 Tel: 1-800-824-0524

Professional Mariner, LLC
 Tel: (603) 433-4440 / Fax: (603) 433-4442

► **Accessories**

ProSport 1.5 Battery Maintainers
Fully automatic, with built-in safety.
LED status indicator, 1-year warranty



Corrosion Control: Galvanic Isolation Products & Systems
ProMariner makes a variety of corrosion control products providing corrosion control protection, isolation & green wire/ground wire monitoring.



Corrosion Control Workbook
Educate yourself on the process of performing a galvanic survey. (Recommended with Corrosion Test Meter Part # 20006)



Test Meters
ProMariner makes a variety of hand held digital test meters for measuring voltage and amperage on-board.



Model	Part No.	Cable Length	Volts	Banks
Handheld DC System Tester	87710	n/a	n/a	n/a
Digital Multi-Meter	60016	3'	12	3
ProSport 1.5 Portable	10115	4'	12	1
ProSport 1.5 On-Board	10116	4'	12	1
Clamp-It Multimeter	87015	n/a	n/a	n/a
ProSafe 1 Single Line Galvanic Isolation System	22086	n/a	120	n/a
ProSafe Isolation Transformers 3.6-12KVA, visit www.promariner.com for details			120/240	n/a
Adjustable Corrosion Monitoring System	22020	n/a	n/a	n/a
Corrosion Monitoring System	22030	n/a	n/a	n/a
Corrosion Workbook	20001	n/a	n/a	n/a

To Place an Order Please Contact Your Local Dealer, retailer or call ProMariner at:
Tel: 603-433-4440 / Fax: 603-433-4442 / www.promariner.com

► **Table of Contents**

CAUTIONS, WARNINGS AND SAFETY INSTRUCTIONS...	2-4
Setup and Operation...	5-7
Selecting a Charging Profile and Understanding Battery Types...	7-8
Installation...	8-13
DC Connections & Wiring Diagrams...	9-11
AC Connections...	12-13
Grounding Connection & Drip Shield Installation...	13
Troubleshooting...	14
Periodic Maintenance...	14-15
Frequently Asked Questions...	15
Accessories...	16
Warranty Information...	17

Thank you from all of us at Professional Mariner, LLC and congratulations on the recent purchase of your ProTech-i Series On-Board Marine Battery Charger. The ProTech-i On-Board Marine Battery Charger is the latest in Advanced Electronic Marine Battery Charging Technology and is ideal for: cuddy, cruiser, sail, house boats, yachts commercial offshore & sport fishing boats.

The ProTech-i Series is designed to be installed in an area where the charger will NOT be subjected to water. Recommended installation is in an engine room or dry compartments where 6 inches of clearance on all sides is available.

The ProTech-i Series battery charger incorporates industry leading technology, delivering fully automatic and Sequential Multi-Stage Charging that provides electronically controlled charging, conditioning and maintenance of all batteries and or banks connected.

High Line Features:

- ✓ Automatic Wide Range / Global AC input 95 - 250VAC
- ✓ Active Battery Balance Control (BBC) monitors charging while conditioning and extending battery life ensuring that no battery is ever overcharged (1230i Plus, 1240i Plus & 2420i Plus only)
- ✓ User Programmable Absorption / Conditioning Mode: 1, 2, 3, or 4 hours.
- ✓ User Programmable Battery Type / Charge Profile Selector- 3 Settings:
Out of Box Factory / User Setting 1 : Flooded (Lead-acid)
User Setting 2 : AGM
User Setting 3 : GEL

Standard Features:

- ✓ Advanced Electronic Technology yielding a heavy duty stylish and compact On-Board Marine Charger.
- ✓ Expanded LED Operation Status Center Includes High Visibility LED's for:
Fast Charge, Absorption, Float, and Discrete Battery Type LED indicators for: Flooded, AGM and GEL Batteries.
- ✓ Fully Automatic & Sequential Multi-Stage Charging (example below is for a 12 Volt ProTech -i model)
Factory set out of the box for Flooded (Lead-acid) battery (s).

Sequential Multi-Stage Battery Charging

- Stage 1** Fast Charge = Maximum Amperage Output until Battery (s) reach 14.7 VDC
- Stage 2** Absorption Charge / Conditioning Mode = Precision 14.7 VDC to Fully Charge & Desulfate Battery(s).
- Stage 3** Float / Maintenance/ Ready Mode= Precision Finishing & maintenance Voltage of 13.5VDC
- Stage 4** Recycle / Dockside Power = If while docked and connected to shore power your Batteries have a continuous excessive DC load for lighting, entertainment, or appliances, etc. The ProTech-i Series will return to Mode 1 providing your batteries up to the full amperage rating of the charger to meet the demand of the load and begin charging your battery (s).

► Important Safety Instructions

⚠ WARNING: HIGH VOLTAGE / ATTENTION : HAUTE TENSION
 AVOID SERIOUS INJURY OR DEATH FROM ELECTRICAL SHOCK. BEFORE OPENING TURN OFF AC SUPPLY POWER. CHOC ELECTRIQUES PEUVENT PROVOQUER LA MORT OU DE SERIEUSE BLESSURES. AVANT D'OUVRIR LA BOITE, COUPER LE COURANT.

⚠ WARNING: LOW VOLTAGE / ATTENTION : BASSE TENSION
 ELECTRICAL BURN AND SPARK HAZARD. BEFORE OPENING DISCONNECT CHARGER CONNECTIONS AT BATTERY(S). (DANGER DE BRULURES ELECTRIQUE ET ETINCELLES). AVANT D'OUVRIR LA BOITE DECONNECTER LES CONNECTIONS ENTRE CHARGEUR ET BATTERIE.

⚠ WARNING / AVERTISSEMENT :
 DO NOT EXPOSE TO RAIN OR SPRAY / NE PAS EXPOSER AUX INTEMPERIES

⚠ CAUTION:
 - HOT SURFACES - TO REDUCE THE RISK OF BURNS, DO NOT TOUCH.
 - CHARGE ONLY USER SELECTABLE TYPE BATTERIES (FLOODED, AGM, GEL OR CALCIUM) OTHER TYPES OF BATTERIES MAY BURST CAUSING PERSONAL INJURY AND DAMAGE
 - RISK OF ELECTRIC SHOCK. NO USER SERVICEABLE PARTS. RETURN TO MANUFACTURER FOR SERVICING
 - THIS CHARGER IS MEANT FOR CONTINUOUS DUTY
 - IGNITION PROTECTED
 - FOR MARINE USE

⚠ ATTENTION :
 - SURFACES CHAUDE-NE PAS TOUCHER, RISQUES DE BRULURES
 - UTILISER POUR ATTENTION: CHARGER UNIQUEMENT LES BATTERIES DU TYPE (PLOMB/ACIDE OU PLOMB/GEL/AGM ET BATTERIE AU CALCIUM). D'AUTRES TYPES DE BATTERIES POURRAIENT ECLATER ET CAUSER DES BLESSURES OU DOMMAGES
 - RISQUE DE CHOCES ELECTRIQUE-RETOURNER AU FABRIQUANT POUR SERVICE.
 - CE CHARGEUR EST FABRIQUE POUR LE DEVOIR CONTINU
 - PROTEGE CONTRE L'EXPLOSION
 - POUR UTILIZATION MARINE

Before connecting to batteries or AC power, read all instructions and cautionary markings on the battery charger and batteries. Do not discard this manual, save it for future reference.

- 1. SAVE THESE INSTRUCTIONS** - This manual contains important safety & operating instructions for ProTech-i Models 1210i, 1215i, 1220i, 1225i, 1230i Plus, 1240i Plus, & 2420i Plus chargers.
2. Do not expose charger to rain or snow.
3. Use of attachments not recommended or sold by Professional Mariner, LLC will void warranty and may result in a risk of fire, electrical shock or personal injury.
4. Do not operate the charger if it has received a sharp blow, direct hit of force, been dropped or otherwise damaged in any way.
5. Do not disassemble the battery charger. If service or repair is required please contact customer service at 1-800-824-0524. Incorrect reassembly may result in a risk of electric shock or fire.
6. To reduce the risk of electrical shock, remove 120 volt or 240 volt AC shore power. Also remove DC battery connections prior to any maintenance or cleaning. Turning off controls will not reduce this risk.

⚠ WARNING AVOID SERIOUS INJURY OR DEATH FROM FIRE, EXPLOSION OR ELECTRICAL SHOCK
 - Make connection in an open atmosphere free of explosive fumes.
 - Make connection in a secure manner that will avoid contact with water.

► Periodic Maintenance Continued

Process:	Check charger for water damage
When:	Monthly
Process:	Visually inspect all wiring for cuts and/or abrasions. Have all damaged or sub standard wiring or electrical hardware replaced to conform to ABYC marine UL standards for AC & DC electrical systems on boats. Consult your local certified ABYC marine electrical technician. Contact ProMariner if your charger needs to be serviced.
When:	Monthly
Process:	Clean and tighten all battery connections. Follow battery manufacturer's instructions for cleaning a battery. Clean all battery terminals with a wire brush where required and tighten all battery connections.
When:	Monthly

► Frequently Asked Questions

- Q: Do I have GEL Cell batteries?**
 A: Look at the battery housing and see if it is identified as a GEL battery. If you do not know what kind of battery you have contact the manufacturer of the batteries you have on-board.
- Q: What do I do if my ProTech-i Series LEDs do not turn on?**
 A: Check to make sure that an AC power connection is made. If LEDs remain off, review the troubleshooting procedure on page 14.
- Q: Will water hurt my ProTech-i Series charger?**
 A: Yes, these are dry compartment chargers and must be mounted in a dry location. Damage caused by water is not covered under the ProTech-i warranty policy.
- Q: How do I change my ProTech-i Series charger to GEL cell mode?**
 A: Please double check that you have a GEL cell battery(s). There is a misconception that AGM is GEL. This is not the case. AGM (Absorbed Glass Mat) battery(s) require a different charge profile than GEL Batteries. If you have confirmed that you have GEL (Gelled Electrolyte Lead-acid) battery(s), simply follow the procedure outlined on page 6 of this manual.
- Q: Does my ProTech-i Series really need 6 inches of all around clearance for ventilation?**
 A: We recommend this for cooling, more clearance is better.
- Q: I think my ProTech-i Series charger is too hot. What should I do?**
 A: The charger will get to the point where it can be touched, but you would not want to carry it across a room. This is normal. *Note: the charger is thermally protected.*
- Q: How do I change the AC input on my ProTech i charger from 120v to 240v?**
 A: The NEW ProTech-i charger is equipped with the most advanced charging technology and will automatically adjust for the correct voltage.

► **Trouble Shooting**

Note: When working with tools near electricity serious electrical shock can occur resulting in injury.

- 1) Turn off all power to the charger and disconnect all the DC cables at the batteries making sure that no cables are in contact with equipment, other wiring, or one another.
- 2) Please note switch positions before changing settings. Set the user programmable battery type selector switch to the Flooded (Lead-acid) position shown on page 6 (Note switch position to reset after troubleshooting is complete).
- 3) Set the user programmable absorption type selector switch to one hour as shown on page 6. (Note: Please make sure to make note of your ProTech i Charger's programmed settings for battery type and absorption time so you can reprogram your charger after troubleshooting is completed).
- 4) Apply AC power. The charger will first be in the Fast Charge Mode, followed by the Absorption / Conditioning Mode. Note: Because the batteries will not be connected during this test the transition from Fast Charge to absorption may be so quick you will not see the change in modes. This is normal and acceptable. Once you have confirmed your ProTech-i Series Charger is in the absorption mode use a digital volt meter (DVM) to check the output voltage of the charger. It should read between 14.6 and 14.7 Volts DC (for the Factory Flooded (Lead-acid) Setting).



- 5) If the voltage is 14.6-14.7 keep the charger's AC power on with the DC outputs disconnected from the battery(s). Leave the charger on for approximately one hour, make sure absorption switch is in one hour setting otherwise it could take up to 4 hours or until float mode is observed. The voltage should drop to 13.5 VDC indicating float mode.
- 6) If you see all of the above voltages, your charger is working correctly. Turn off the charger and reprogram your ProTech i charger back to your original program settings. Place end caps back on and reapply AC shore power to charger.
- 7) If you don't see the initial 14 VDC, the charger either has a blown fuse, or a circuit board failure. Please contact ProMariner's Customer Service 1-800-824-0524 or email us at: info@promariner.com

► **Periodic Maintenance**

Process:	Per battery manufacturers' instructions monitor and maintain proper levels of distilled water. (not tap or bottled water that contains minerals) in each battery
When:	Monthly

► **Important Safety Instructions Continued**

7. WARNING – RISK OF EXPLOSIVE GASES.

- a) WORKING IN THE VICINITY OF A LEAD-ACID BATTERY IS DANGEROUS. BATTERIES GENERATE EXPLOSIVE GASES DURING NORMAL BATTERY OPERATION. FOR THIS REASON, IT IS OF UTMOST IMPORTANCE THAT EACH TIME BEFORE USING YOUR CHARGER, YOU READ THIS MANUAL AND FOLLOW THE INSTRUCTIONS EXACTLY.
- b) To reduce risk of battery explosion, follow these instructions and those published by battery manufacturer and manufacturer of any equipment you intend to use in vicinity of a battery(s). Review cautionary markings on these products.

8. PERSONAL PRECAUTIONS

- a) Someone should be within the range of your voice or close enough to come to your aid when working near a Lead-acid battery.
- b) Have plenty of soap and water nearby in case battery acid comes in contact with skin, clothes or eyes.
- c) Wear complete eye protection and clothing protection. Avoid touching eyes while working near battery(s).
- d) If battery acid contacts skin or clothing, wash immediately with soap and water. If acid enters eye, immediately flood eye with running cold water for at least 10 minutes and get medical attention immediately.
- e) NEVER smoke or allow a spark or flame in the vicinity of a battery or engine.

CAUTION - To reduce the risk of injury, charge only Lead-acid type rechargeable batteries (Flooded, Sealed Flooded, GEL (Gelled Electrolyte Lead-acid) or AGM (Absorbed Glass Mat)). Other types of batteries may burst, causing personal injury. The ProTech-i is factory set for Flooded (Lead-acid) batteries. **Check the position of the battery type selector switch before applying power to insure the charger is in the correct setting for the battery type. This switch is located on the DC end of the charger see Page 5.**

- Incorrect assembly may result in electrical shock or fire.
- f) Be extra cautious to reduce risk of dropping a metal tool onto a battery, it might spark or short-circuit the battery or other electrical hardware that may cause a fire or explosion.
 - g) Remove all personal metal items such as rings, bracelets, necklaces, watches, and jewelry when working near a battery. A battery can produce a short circuit current high enough to weld a ring or any other metal, causing serious burns.
 - h) Do not use the battery charger to charge dry cell batteries that are commonly used with home appliances i.e. a cordless power drill battery. These batteries may burst and cause injury to persons and damage to property.
 - i) NEVER charge a frozen battery.

► Important Safety Instructions Continued

9. PERSONAL SAFETY WHILE PREPARING TO CHARGE BATTERIES ON-BOARD OR OFF-BOARD

- If necessary to remove a battery(s) from a boat to charge, always remove the negative (-) grounded terminal from battery first. Make sure all accessories in the boat are off, so as not to cause an arc.
- Be sure the area around the charger and batteries is well ventilated while the batteries are being charged. Gases can be forcefully blown away using a piece of cardboard or other nonmetallic material as a fan.
- When cleaning battery terminals wear full eye protection to prevent corrosive material from coming in contact with eyes.
- Add distilled water (**not tap or bottled water that contain minerals**) in each cell until electrolyte reaches the levels specified by the battery manufacturer. Do not overfill. For batteries without fill caps, carefully follow manufacturer's recharging instructions.
- Study all battery manufacturer's specific precautions such as removing cell caps while charging and recommended rates of charge.
- Determine battery type / charge profile for battery (s) by referring to the boat owner's manual / electrical equipment(s) package and/or the manufacturer's specifications located on each battery. Make sure Battery Type and Charge Profile are properly selected before charging your batteries.

10. ON-BOARD MARINE BATTERY CHARGER COMPARTMENT SAFETY AND LOCATION REQUIREMENTS

- Refer to the installation section of this manual for installation of your battery charger. Be sure all electrical connections and cables are in compliance with ABYC E-11 standards for proper fusing, bundling and strain relief.
- Never place the charger directly above the battery(s) being charged; gases from battery will corrode and damage charger.
- Never allow battery acid to drip on the charger when reading specific gravity or filling battery.
- Do not operate the charger in a closed-in area or restrict ventilation in any way.
- Do not set the battery(s) on top of charger.

AC GROUNDING INSTRUCTIONS - The Ground (GND) terminal of the AC input connector must be connected to the AC grounding system at the AC ground buss.

DC GROUNDING INSTRUCTIONS - The case grounding stud should be connected to the DC negative grounding buss (same location as the DC negative output cable terminal) with a cable one size smaller than the DC negative output cable.

ProTech-i Series Dry Compartment Installation Requirements:

Install / Mount your ProTech-i Series in a dry compartment that is protected from coming in contact with Water, and non service personnel.

NOTE: The ProTech-i Series is not intended to be mounted in an open cockpit or deck mounting where weather is a factor.

NOTE: The ProTech-i Series models are required to be mounted in the vertical position with the supplied drip shield. This is required to be in compliance to Marine UL Standards.

► DC Grounding Installation



DC Grounding Connection
(DC Case / Chassis Ground $\overline{///}$)
see system wiring illustrations
on page 11

9) The case DC grounding connection (DC Case / Chassis Ground $\overline{///}$) should be connected to the boat's DC negative / common ground buss using a cable one gauge smaller than the negative battery cable.

Note: The DC negative buss/common ground is the same negative (-) connection point used for the charger's negative (-) DC output post connections.

10) After all cables are in place re-check connections making sure all connections are tight. Confirm, the charger is in a dry location. Damage caused by water is not covered under the ProTech-i Series warranty.

► Drip Shield Installation

ProTech-i mounted with drip shield 1" above the flange of the unit. Make sure to properly center and mark for installation the drip shield provided 1" over the top of the ProTech-i Series Charger. Drip shield protects your ProTech-i Series Charger from any moisture that can build up due to harsh marine environmental effects or elements.

Please use stainless steel screws properly sized for your boat. **Mounting Screws Not Included.**

Please note: Damage caused by water is not covered under the ProTech-i Series warranty.

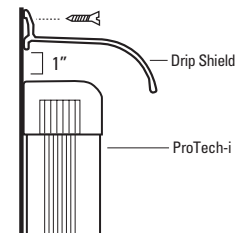

► Applying AC Power

11) Apply AC power, Battery Type LED will turn on to indicate the battery type selected as determined by the selector switch shown on page 5. The Fast Charge LED will illuminate until proper voltage is achieved. Next, the Fast Charge LED will turn off and Absorption LED will illuminate. The Absorption LED will turn off after 1 to 4 hours depending upon the selection of the absorption timer switch shown on page 6. After absorption mode is complete the Float LED will illuminate. In Float mode your boat's battery(s) are fully charged and are being maintained at the optimal battery voltage and will supply DC power for house loads of any type up to the maximum output of the charger. The ProTech-i Multi-Stage Modes are Fast Charge, Absorption (conditioning), Float (Maintenance and Storage) and dockside power.

▶ AC Connections

5) AC power should not be present until step 10 is completed. After connecting the AC and DC cables to the charger use cable support on the cables within 6" of the charger for both the AC and DC cables.

6) Be cautious when connecting battery cables to the charger and check to make sure AC power is off. Be careful when placing battery cables near one another to avoid possible shorting or arcing (sparking) that can occur when positive and negative wires touch.

7) USA 120 Volt or European 230 Volt AC Connections: (For USA 240V AC please refer to step #8). A terminal strip is provided on the charger for AC power input. Connect Black (Europe-Brown) to the terminal marked Line. Connect White (Europe-Blue) to the terminal marked Neutral. Connect Green (Europe-Green/Yellow) to the terminal marked (Ground/ Earth). Install an appropriate circuit breaker dedicated to the charger at the boat's electrical panel. Please refer to the table at the bottom of the page for minimum protective AC fuse or circuit breaker sizes.

8) USA 240 Volt AC Connections: (If using 120 volt AC or European 230 volt AC please refer to step #7 and ignore this step). A terminal strip is provided on the charger for AC power input. Connect Black to the terminal marked Line. Connect Red to terminal marked Neutral. Connect Green to the terminal marked (Ground/ Earth). Install an appropriate circuit breaker dedicated to the charger at the boat's electrical panel. Please refer to the table at the bottom of the page for minimum protective AC fuse or circuit breaker sizes.



L = LINE
N = NEUTRAL
G = GROUND

Shown Above: AC terminal block. Please note the connections and wire appropriately. The circuit board is also labeled to indicate proper connections.

Please note: All AC wire connections and installations must be made in compliance with ABYC E-11

Minimum Amp Ratings when selecting AC breaker sizes	Charger Model	110 volt breaker	220-230 volt breaker
	ProTech1210i	6 Amp	4 Amp
ProTech1215i	7 Amp	5 Amp	
ProTech1220i	8 Amp	6 Amp	
ProTech1225i	11 Amp	7 Amp	
ProTech1230iPlus	11 Amp	7 Amp	
ProTech1240iPlus	14 Amp	8 Amp	
ProTech2420iPlus	14 Amp	8 Amp	

Minimum AC Wire Size examples with Marine grade wire rated at 105° C for 10 feet in length: 14 AWG = up to 15 amps, 12 AWG = up to 20 Amps

(See ABYC E-11 for exact wire sizes for length of run, ampacity, temperature, location and number of wires in bundles.)

▶ Setup and Operation

1) Install your ProMariner battery charger by referring to page 8 of this manual.

2) After installation is complete including AC and DC connections please ensure proper fusing and strain relief have been properly installed..

3) After proper installation, apply AC power and observe the following. Example for Factory Flooded (Lead-acid) setting

- a. Battery Type LED will turn on as controlled by the battery type selector switch. (Shown on Page 6)
- b. Fast Charge LED will illuminate until battery voltage reaches approximately 14.2 Volts DC, at which time the Fast Charge LED will turn off. The Absorption LED will then illuminate.
- c. Absorption LED will continue to be on for 1-4 hours as determined by the user programmable Absorption timer switch.
- d. After 1-4 hours the Absorption LED will turn off and the Float light will illuminate indicating the battery charger is in Float mode.
- e. In Float mode the batteries are fully charged and will be maintained at the selected finishing/maintenance voltage for the battery type selected. In Float mode your ProTech-i Series Charger will supply DC power for house loads of any type up to the maximum rated amperage output of the charger.



Shown Above - Programmable Absorption and Battery Type Selector Switches. Please refer to page 6 for settings and selections.

After the Fast Charge cycle, Absorption time is determined by the user programmable absorption timer switch shown in the figure above.

Full-rated battery charger amperage is available while in Float Mode.

Note: The charger is equipped with an internal temperature sensor that will shut down the charger in the event of thermal overload.

Note: Your ProTech-i charger is equipped with a fan, which is temperature controlled and will only run when cooling is necessary.

Your ProMariner Marine Battery Charger is self current limiting with built in: over temperature, overvoltage, reverse polarity and ignition protection for boating safety and peace of mind. If at any time you have trouble configuring your ProTech-i Series Charger or need technical information please call ProMariner at 1-800-824-0524 8:30 am to 5 pm Eastern Time, or email us at info@pmariner.com.

Setup and Operation Continued

Programmable Battery Type Selector Switch

Your battery charger has a user programmable battery type selector switch that is factory set for Flooded (Lead-acid) battery(s). Please confirm the appropriate battery type and the orientation of selector switch before use.

In order to change the factory setting from Flooded (Lead-acid) to either AGM or GEL type batteries, simply, remove AC power to the battery charger, remove the end cap cover on the DC end of the charger and locate the user programmable battery selector switch. Shown below you will find the three battery type configuration settings that are used to program the 3 position dip switch as shown below. Choose the correct one for your battery type. **If you are unsure as to what kind of battery you have please refer to "Selecting a Charging Profile & Understanding Battery Types" on page 7.** Once your ProTech-i is programmed for your battery type, reinstall DC endcap. Apply AC power. The Battery Type LED will illuminate indicating your selection.

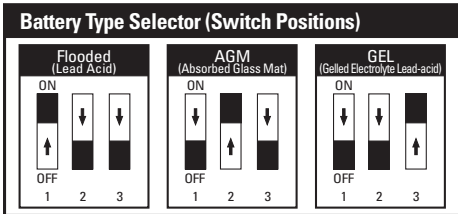

Note: If more than 1 battery type is illuminated, recheck your battery type selector switch positions as illustrated above. It should be noted, only (1) of the 3 switch tabs located on top of the 3 tab dip switch can be in the "ON" position for proper selection and operation.

Programmable Absorption Timer Switch

The ProTech-i Series is equipped with a programmable absorption timer switch that places the charger into the absorption / conditioning mode for a period of 1,2,3 or 4 hours as programmed and indicated by the switch selection. Determine the best absorption / conditioning time either by obtaining your battery manufacturers recommended specifications or by using the guidelines on page 7. Below are the 1,2,3 and 4 hour switch configuration settings that are used to program the 3 position dip switch to the desired length of time.

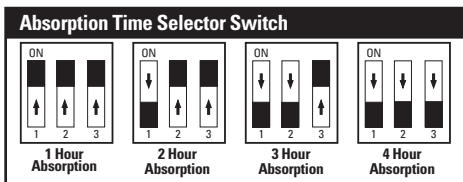

Typical 12 Volt DC Common Ground Installation Wiring Diagrams

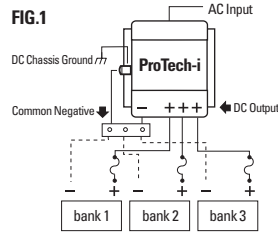

Three Bank / 12 Volt DC Installation (FIG.1)
Connect DC cables to three of the positive DC output posts as shown. Connect common ground negative wire (as described below)

Two Bank / 12 Volt DC Installation (FIG.2)
Connect DC cables to two of the positive DC output posts and use one jumper wire to connect the unused post. Connect common ground negative wire (as described below)

One Bank / 12 Volt DC Installation (FIG.3)
Connect to one positive DC output post and use two jumpers to connect to the remaining unused posts. Connect common ground negative wire (as described below)

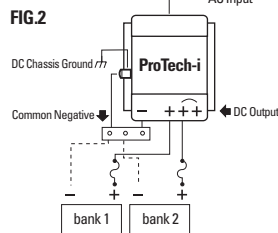

Battery negative wires are installed separately to the boat's DC Negative / Ground buss bar (not provided). Then a single connection is made to the charger. Note: See page 13 for DC Chassis Ground connection details.

Table No.1 Wire gauges by amp rating and total out and back wire distance as defined by the length of the positive wire which must be added to the length of the return negative wire.

12 Volt 10 Amp	Length Out and Back				
Wire length	10'	15'	20'	25'	30'
AWG	14	12	10	10	10
12 Volt 15 Amp	Length Out and Back				
Wire length	10'	15'	20'	25'	30'
AWG	12	10	10	8	8
12 Volt 20 Amp	Length Out and Back				
Wire length	10'	15'	20'	25'	30'
AWG	10	10	8	6	6
12 Volt 25 & 30 Amp	Length Out and Back				
Wire length	10'	15'	20'	25'	30'
AWG	10	8	6	6	4
12 Volt 40 Amp	Length Out and Back				
Wire length	10'	15'	20'	25'	30'
AWG	8	6	6	4	4
24 Volt 20 Amp	Length Out and Back				
Wire length	10'	15'	20'	25'	30'
AWG	14	12	10	10	10

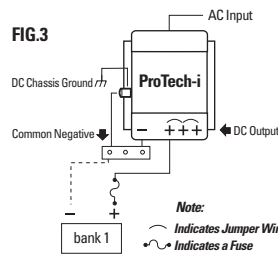

(ABOVE) It is recommended that a jumper(s) be used between unused positive DC output post(s) and a used positive DC post connected on your ProTech-i Series Charger. Please note you can connect all three positive DC output posts together to form a single DC output on your ProTech-i Series Charger.

All installations should be made in compliance with ABYC E-11 specifications for AC and DC electrical systems on boats and specifications for A-31 Battery Chargers and inverters.

▶ DC Installation Continued



Shown Above: ProTech-i Plus model. The circuit board is clearly marked to identify the polarity of each DC output connection.

Note: For your safety the charger is equipped with an internal temperature sensor that will shutdown the charger in the event of thermal overload.

Note: Your ProTech-i charger is equipped with a fan, the fan will only run when needed. The fan is temperature controlled and will only turn on when cooling is necessary.

4) Battery cables, connections and installation must comply with ABYC E-11 and A-31 standards. To avoid risk of injury, fire or an explosion, ProMariner requires that when making a wire connection to **EACH BATTERY(s)** Positive (+) Post, install the positive cable with an over current protection fuse within 7 inches of connection to the battery or battery connection point. The fuse rating should be at least 10 amps higher than the rated full output of the charger. See ABYC E-11 for specific requirements. Over current protection within 7 inches of the **charger's negative (-) DC output post** is not required as the ProTech-i is self limiting and can not exceed its rated current output. The internal fuses protect the unit against reverse polarity.

▶ Typical 12 Volt DC Common Ground Installation Wiring

For 24 Volt installations, always make sure you have a 24 Volt Common Ground ProTech-i Series Charger, and that your batteries are configured in series as a 24 Volt battery bank or banks. Each 24 Volt bank will require a 24 Volt positive connection. Not sure you know what voltage system you have on board your boat? Contact your local certified ABYC marine electrical technician.

Installation Note: Preventing a short circuit of "live" DC Wires can be accomplished with the following proper steps:

- 1) Always connect the positive (+) DC output cables to the charger first.
- 2) Connect the remaining end of the DC cables to the required Protective fuse or DC breaker 4 to 7 inches from the battery positive (+) post with the fuse out or the DC breaker in the off position.
- 3) Once all of the above wiring connections are completed and inspected, proceed with the protective fuses out of the holder and or the protective breakers in the off position, make your final connections from the protective devices to the Positive (+) posts of the associated Battery (s). Proceed to make the DC Ground Connection from the Charger to the DC common Ground Buss followed by the Negative (-) Connections from the Battery (s) to the DC common Ground Buss. When all wiring is completed install the protective fuses and or turn on the protective DC breaker(s). See illustrations on page 11.

▶ Setup and Operation Continued

General recommendation for the Absorption Timer Switch is as follows:

Single Group 24 or Group 27...	2 Hours
Two Group 24, 27 or Single Group 31...	3 Hours
Single 4D or 8D...	4 Hours
Multiple 4 or 8Ds or Multiple...	4 Hours

*****ACTUAL SWITCH SETTINGS ARE SHOWN ON PAGE 6*****

▶ Selecting a Charging Profile and Understanding Battery Types

There are three primary types of batteries; Flooded (Lead-acid), AGM (Absorbed Glass Mat) and GEL Cell (Gelled Electrolyte Lead-acid). Traditionally, the most common type of batteries used are Flooded (Lead-acid batteries).

Almost all GEL Cell Batteries will state that they are GEL Cell on the battery case or labels.

Battery Type	12 Volt Charging Profile	24 Volt Charging Profile	Battery Information
Flooded (Lead-acid)	14.7 Absorption, 13.5 Float	29.4 Absorption, 27.0 Float	Electrolyte (with or without removable caps)
AGM (Absorbed Glass Mat)	14.4 Absorption, 13.3 Float	28.8 Absorption, 26.6 Float	Sealed
GEL (Gelled Electrolyte Lead-acid)	14.1 Absorption, 13.8 Float	28.2 Absorption, 27.6 Float	Sealed

NOTE: AGM (Absorbed Glass Mat) batteries are not GEL (Gelled Electrolyte Lead-acid) batteries. AGM batteries are charged with a completely different charge profile when compared to GEL batteries.

***If you are unsure as to what kind of battery you have, we recommend that you contact the manufacturer of the battery.

ProMariner battery maintainers are designed to keep batteries charged during the off season to maintain the life of your battery. ProMariner maintainers keep a battery voltage at a safe level so that a battery does not self discharge. For more information please visit www.promariner.com or call 1-800-824-0524 for a dealer or retailer near you.

► Charging Information

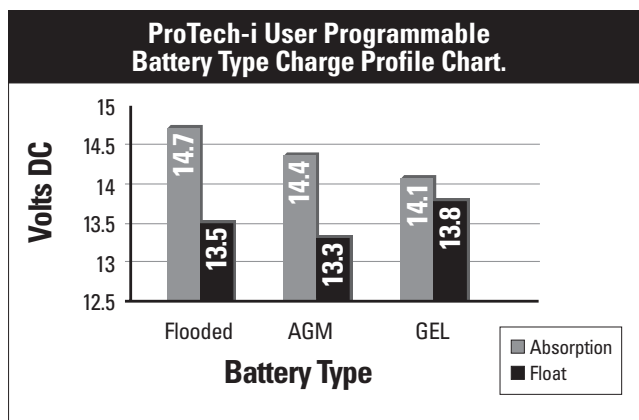

► Installation

Please Note: This manual is written describing 12 Volt ProTech-i models. For 24 Volt Models please read the bold note directly below.

Note: For 24 Volt installations, always make sure you have a 24 Volt Common Ground Protech-i Series Charger, and that your batteries are configured in series as a 24 Volt battery bank or banks. Each 24 Volt bank will require a 24 Volt positive connection. Not sure you know what voltage system you have on board your boat? Contact your local certified ABYC electrical technician.

The ProTech-i battery charger will automatically operate from 95 to 250 VAC, 50/60 Hz single phase. The charger is designed for the marine environment, with an epoxy painted aluminum case for effective heat dissipation and corrosion resistance. The charger should be permanently mounted and wired directly to battery(s) or associated battery switches per ABYC E-11 standards for AC and DC electrical systems on boats.

Your ProTech-i Series is equipped with a user programmable battery type selector switch that is factory set for Flooded (Lead-acid). To change your battery type / charge profile, please refer to the "Selecting a Charging Profile" section of your owner's manual. (Page 7)

Don't know what kind of battery(s) you have? Refer to Page 7 of this manual on "Understanding Battery Types" or contact the manufacturer of your battery(s).

► Installation Continued

- 1) Make sure to mount the charger in a dry ventilated location with easy access. Remember to leave plenty of room for battery cables and AC wiring.
- 2) Six inches of clearance minimum is required on all sides. (Including the front / face) Make sure to leave room for the drip shield to be mounted as illustrated on page 13.
- 3) Use the ProTech-i as a template for drilling four 1/8" pilot holes. Stainless Steel self tapping screws (#10 X 3/4" are recommended) or drill four 3/16" through holes if using 3/16" through bolts with washers, lock washers and nuts, (in mounting areas that can allow for thru hole mounting).

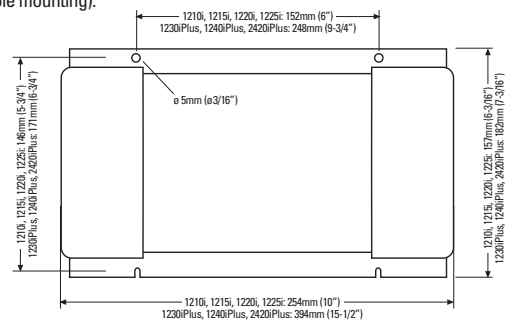

Please note: Dimensions are nominal measurements
 Stainless steel mounting screws and hardware not included

► DC Installation



Shown above is the ProTech-i split DC endcap. Please note that this is a two piece end cap. To remove simply unscrew the two self tapping screws on the top of the DC end cap and slide top cap off. This will allow access to the low voltage DC terminals for connections of cables.