

OCEANIS 48

Owner's Manual



Code: 134827
Index H

Welcome aboard

Madam, Sir,

You have just taken delivery of your new BENETEAU boat and we thank you for the confidence you have shown us in ordering a vessel of our brand. The whole BENETEAU team welcomes you aboard.

A BENETEAU is made to last, in order to bring you all the pleasure you expect from a vessel over a period of many years. Each boat is subject to the utmost attention to detail from the design stage right through to launching.

This manual is meant to help you to enjoy your boat comfortably and safely. It includes the boat specifications, the equipment provided or installed, the systems and tips on her operation and maintenance. Some of the equipment described in this manual may be optional.

Your BENETEAU dealer will be able to help and advise you in the use and maintenance of your boat.

**Read this user's guide/owner's manual carefully and get to know your boat before using it.
The better you know your vessel the more pleasure you will get from being at the helm.**

The sea is a source for learning. Caution based on a knowledge of one's own limits and those of the boat is the pre-requisite for an accomplished sailor.

Even when your boat has been adapted for them, the sea and wind conditions corresponding to the design categories A, B, C and D may vary, ranging from severe conditions to strong storms subject to the risks of exceptional waves and gusts of wind, this meaning they are dangerous conditions in which only an experienced, fit and well trained crew manoeuvring a well maintained boat can sail in a satisfactory manner.

This user's guide/owner's manual is not a course in safety at sea or about sailing sense. If this is your first boat or if you change to a new type of boat which you are not used to, get some training in boat control and sailing to ensure your safety and comfort. Your dealer, your international sailing association or your yacht club will be very happy to recommend local sailing schools or professional instructors.

Make sure the sea and wind conditions will correspond to the category of your boat and you and your crew are able to handle the boat in these conditions.

Always listen to the weather forecast before you put out to sea.

Keep this user's guide/owner's manual in a safe place and hand it over to the new owner if you sell your boat.
You are advised to keep all the instructions and manuals provided by the boat equipment manufacturers (accessories...) in the same place as this manual

Introduction

The users of the boat are informed of the following:

■ This user guide/owner's manual is not a maintenance or repair guide. In case of difficulty do not hesitate to call on the services of your concessionaire BENETEAU.

■ Any alterations which may affect the safety specifications of the boat must be assessed, carried out and recorded by persons qualified to do so. Any change in the distribution of the vessel's mass (adding a radar, altering the mast, changing an engine, etc) may affect the stability, trim and performance of your boat.

The BENETEAU shipyards may not be held responsible for any alterations which they have not approved.

■ The complete crew must be equipped appropriately.

■ In numerous countries, a licence, an authorization or a training course is requested. Make sure you have this legal authorization before you use your boat.

■ Adapt the use of your boat to her condition that wears out with time and use.

■ Any boat, however solid she may be, may be severely damaged if badly used. This is not compatible with safe navigation. Always adapt the speed and direction of your boat to the conditions of the sea.

■ The boat shall not be loaded more with than the maximum load recommended by the builder, in particular the total weight of the food supplies, of the different equipment that are not supplied by the builder and of the persons on board.

■ The weight of the boat shall be properly distributed.

■ The stability is reduced when you add weight in the upper parts.

■ In case of heavy weather, the hatches, lockers and doors shall be closed in order to minimize the risk of water coming in.

■ Breaking waves are a serious threat to stability.

■ The water in the bilge shall be kept at its minimum.

■ The stability may be reduced when you tow a boat or when you lift heavy weights with the davits or the boom.

■ If your boat is equipped with a liferaft, carefully read the instructions. The boat must have on board all the proper safety equipment (lifejackets, buoys, harness, flares, liferafts, etc.) depending on the type of vessel, its certification, the country, the weather conditions encountered, etc.

■ The crew must be familiar with the use of all the safety equipment and the emergency safety procedures (MOB, towing etc.). Sailing schools organise regular training sessions.

■ Anyone on the deck shall wear a life jacket or a buoyancy aid.

The safety regulations as defined by the sailing code and enforced by the "COLREG" should be observed.

Introduction

Name plate:

Some of the data is shown on the manufacturer's plate fixed to the boat. The explanation of the data is given in the appropriate chapters of this manual.

Identification of vessel:

The vessel's identification is found on the builder's certificate delivered with the boat and is engraved on the starboard aft side.

So as to be able to continuously improve their product the BENETEAU shipyards reserve the right to make any alterations in design, layout or equipment which they judge necessary.

That is the reason why the specifications and information given are not contractual, they may be modified without prior notice or updates.

This owner's manual is designed in accordance with the ISO 10240 standard requirements, it has a general purpose and it may sometimes list some equipment or accessories or deal with some points or questions that are not relevant to your own boat.

The different warnings used throughout this guide are broken down as follows.



DANGER

Indicates the existence of a serious inherent danger with a high risk of death or serious injury if the appropriate precautions are not taken



WARNING

Indicates the existence of a danger which could lead to injury or death if the appropriate precautions are not taken



PRECAUTION

Indicates a reminder of safety practice or draws attention to dangerous practices which could cause injury to persons or damage to the vessel or to its components



ADVICE - RECOMMENDATION

Indicates a recommendation or advice for carrying out manoeuvres appropriate for the planned manoeuvres

HISTORY OF UPDATES

- Index A 12/2011
- Index B08/2012
- Index C03/2013
- Index D09/2013
- Index E01/2014
- Index F06/2014
- Index G07/2015
- Index H09/2015

Contents

.....	Introduction	
7.....	General specifications	1
13.....	Safety	2
31.....	Hull	3
39.....	Deck	4
53.....	Steering system	5
59.....	Rigging and sails	6
77.....	Interior	7
83.....	Water and sewage water	8
97.....	Electrical equipment	9
121.....	Engine	10
151.....	Launching	11
155.....	Winter Storage	12
.....	Personal notes	

General specifications

- Technical specifications
- Certification
- Design category
- Your boat

■ . TECHNICAL SPECIFICATIONS - OCEANIS 48.

L.O.A	14,60 m
Hull length.....	14,27 m
L.W.L.	13,86 m
Overall width.....	4,74 m
Beam	4,74 m
Waterline beam	3,83 m
Air draught - Empty vessel - Short mast.....	19,40 m
Air draught - Empty vessel - Roller furling mast & Classic	21,69 m
Draught - Deep draught keel	2,17 m
Draught - Shallow draught keel	1,96 m

■ CERTIFICATION

Version	Light displacement	Displacement with maximum load
Deep draught keel - Classical mast	12 558 kg	16 458 kg
Deep draught keel - Roller furling mast	12 594 kg	16 494 kg
Shallow draught keel - Classical mast	13 068 kg	16 968 kg
Shallow draught keel - Roller furling mast	13 104 kg	17 004 kg

Design category (All versions)	A	B	C	D
Maximum number of persons	11	12	14	14

Maximum load recommended by the builder 3 900 kg

Including the mass of the persons who are authorized on board (75 kg/ 165 lbs per adult), the supplies, the liquids that can be used (fresh water and fuel) in fixed completely full tanks, the additional loads, the optional equipments, the liferaft and the scope for load.

Nominal maximum propulsion power
(at the propeller output)..... 58,8 Kw

Maximum recommended engine size 269 kg

Total mass of liquids (all tanks full) 1 281 kg

Freshwater capacity 330 l + 2 x 165 l

Sewage water capacity (in each bathroom) 73 l / 64 l

Fuel oil tank capacity 200 l + 200 l

Refrigeration unit capacity 100 l + 130 l

Battery capacity - Service 2 x 140A

Spare batteries - Service 2 x 140A

Battery capacity - Motor 110 Ah

Battery capacity - Bow thruster 4 x 50 Ah

Battery capacity - Generator 110A

Cabins 2/3/4/5

Build material: Laminated polyester

Architect..... BERRET - RACOUPEAU

Interior design NAUTA Design

Note: The capacities indicated are maximum (including options).

General specifications 1

DEFINITION OF DESIGN CATEGORIES.

Design category	Wind force (Beaufort scale)	Significant height of waves to be considered (in metres H 1/3)
Vessel designed for navigation:		
A - "At high sea"	Over 8	Over 4 m
B - "In open sea"	Up to and including 8	Up to and including 4 m
C - "Near to the coast"	Up to and including 6	Up to and including 2 m
D - "In sheltered waters"	Up to and including 4	Up to and including 0,5 m

SAILS SURFACE	
Classical mainsail	54,5 m ²
Furling mainsail	44 m ²
Furling genoa	55 m ²
Code 0	94 m ²
Asymmetrical spinnaker.....	159 m ²

SAILS - ROLLER FURLING MAST	
I	18 750 mm
J	6 064 mm
P.....	17 480 mm
E.....	5 555 mm

SAILS - CLASSICAL MAST	
I	18 750 mm
J	6 064 mm
P	17 098 mm
E	5 555 mm

The sails are the main propulsion means of the OCEANIS 48.

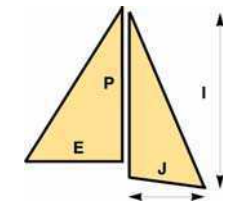

Category A: At high sea

The boat is designed to sail in winds that may exceed Beaufort force 8 and in waves of a significant height of 4 metres and more.

This craft is largely self-sufficient. Abnormal conditions such as hurricanes are excluded.

Such conditions may be encountered on extended voyages, for example across oceans, or inshore when unsheltered from the wind and waves for several hundred nautical miles.

Category B: In open sea

The boat is designed to sail in winds not exceeding Beaufort force 8 and in corresponding seas (waves of a significant height of less than or equal to 4 metres).

Such conditions may be encountered on offshore voyages of sufficient length, or on coastal waters when unsheltered from the wind and waves for several dozens of nautical miles.

These conditions may also be experienced on inland seas of sufficient size for the wave height to be generated.

Category C: Near to the coast

The boat is designed to sail in winds not exceeding Beaufort force 6 and in corresponding seas (waves of a significant height of less than or equal to 2 metres). You may meet with such conditions in exposed inland waters, in estuaries and in coastal waters with moderate weather conditions.

Category D: In sheltered waters

The boat is designed to sail in winds that may exceed Beaufort force 4 and in waves of a significant height of 0,5 metres and more.

Such conditions may be encountered in sheltered inland waters, and in coastal waters in fine weather.

NOTE:

- The significant wave height is the mean height of the highest one-third of the waves, which approximately corresponds to the wave height estimated by an experienced observer. Some waves will be double this height.

- The creation of different design categories results from the need to distinguish between different levels of risk according to the construction of the boats.

"The parameters for the characteristics are established to define the conditions of navigation which each category may encounter; they serve purely to evaluate the boat designs and are not to be used to limit the geographical areas in which these boats may operate".

- One boat may be classed in several design categories at the same time, each with their different maximum capabilities.

Your boat

Name of the owner:

Name of the boat:

Address:

Delivery date:

.....

Registration number:.....

Telephone:.....

Serial number (C.I.N):

email:

Entrance door key n°:

Telephone N° / Address to be contacted in case of emergency

Engine type		
Serial number		
Engine key number		



Safety

- Safety Equipment
- General information
- Gas system
- Recommendations for gas
- Fight against fire
- Bilge pump system
- Emergency tiller

■ . SAFETY EQUIPMENT.



REF	Designation
1	Position of swimming ladder (means of coming back onboard)
2	Location: Scale of help
3	Position of the liferaft



**Swimming ladder
(means of coming back onboard)**

(Ref 1)



Scale of help

(Ref 2)



Storage locker for liferaft (not supplied)

(Ref 3)

■ . GENERAL INFORMATION.

DANGERS

The major hazards concern:

- The gas system.
- The electrical system.
- Manoeuvring the vessel and the sails.
- The motorisation.

Please refer to the relevant paragraphs.



DANGER

- Fuel leaks or vapour represent a danger of fire and explosion.
- Leave the engine compartment ventilated for a long time before starting the engine.
- There may be danger of fire or explosion if direct current systems are incorrectly used.
- Some boats are equipped with a retractable ladder or removable. Make sure the ladder is in place and deployed as soon as you are on board.
- Reduce speed in waves.



WARNING

- Before you sail, list the compulsory safety equipment.
- Don't exceed the number of persons indicated in the chapter 'Specifications'.
- The total weight of the persons and equipment must never exceed the maximum load recommended by the manufacturer.
- Use the seats provided.



ADVICE - RECOMMENDATION

- When sailing, never padlock or lock the liferaft locker.
- Before putting to sea, carefully read the launching instructions shown on the liferaft.
- Close the deck hatches and portholes before each trip (including the companionway hatch in heavy weather).
- Don't store anything below the floorboards.
- Ensure that movable items are firmly secured when the boat is under way.

. GAS SYSTEM.

LOCATION

2 and 3-cabin versions

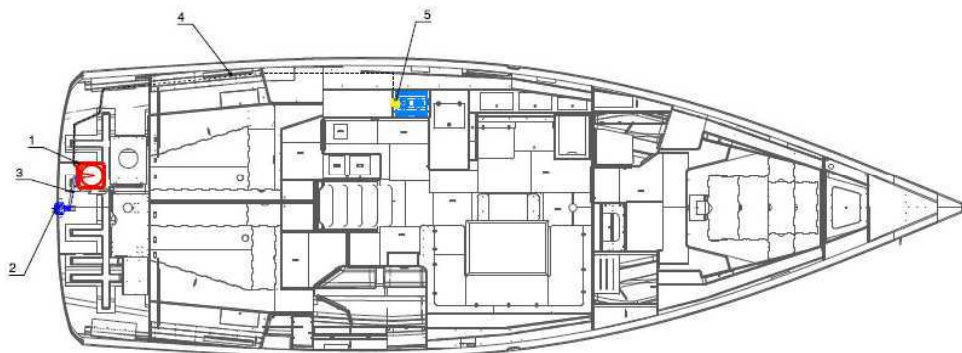

4 and 5-cabin versions

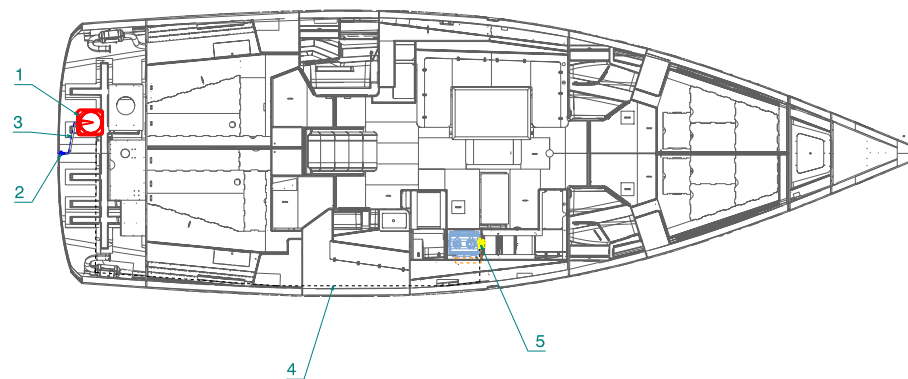

REF	Designation	REF	Designation
1	Gas cylinder locker	4	Gas system
2	Kitchen sink evacuation through-hull	5	Valve - Stop
3	Drain - Gas cylinder locker		



Supply valve - Gas



A pictogram helps to locate it easily



Valve

6 - Open position
7 - Closed position



Gas cylinder locker

Safety 2

RECOMMENDATIONS FOR GAS.

Type of cylinder: butane, service pressure 10 kg/cm² or according to current standards of your country).

Close the valves on the system and on the cylinder when the appliances are not used. Close the valves before you change cylinders and immediately in case of emergency.

Never leave unattended an appliance that is working. Don't install or store flammable materials above or over the stove (curtains, papers, napkins etc.).

Make sure that the valves of the appliances are closed before you open the cylinder or hose valve.

In case you smell gas or find that the burners have gone out (although appliance models cut off automatically if the flames go out), turn off the valves of the appliances. Do ventilate the boat in order to get rid of any residual gas. Find the cause of the problem.

Regularly test the gas system in order to detect any gas leak.

Check all the connections using water and soap or detergent, closing the valves of the appliances and opening the valve on the cylinder.

If you detect a leak, close the valve of the cylinder and repair before you use it again.

The appliances use the oxygen of the cabin and release combustible gases. Ventilate your boat when using appliances.

Don't obstruct the air vents and at least leave the door open. Don't use the oven or stove as back up heaters.

Lock the stove oven when being not used in order to avoid damaging the tubes when sailing.

Never obstruct the fast access to the components of the gas system. Keep the taps of the empty cylinders turned off and the cylinders disconnected.

Keep the protection, lids, covers and taps in their places.

Don't use the gas cylinder storage place to store other equipment. Only use the proper locker to store the gas cylinders.

Regularly check and replace the rubber tubings that link the cylinder to one end of the circuit and the stove to the other one, depending on the norms and regulations in force in your country.



WARNING

- Don't use a solution containing ammonia.
- Don't use a flame to detect leaks.
- Don't smoke, don't use a naked flame when you change the gas cylinder.



WARNING

- Do not use a solution containing ammonia to detect leaks.
- Don't use a flame to detect leaks.
- Don't smoke, don't use a naked flame when you change the gas cylinder.



ADVICE - RECOMMENDATION

- Shut off the gas supply at the bottle as well as the cooker tap.
- When changing the cylinder, refit the cap in place on the regulator threaded section (to avoid corrosion).
- For winter storage instructions and precautions, refer to Chapter 12.

SCHEMA GAS - VERSION EUROPE

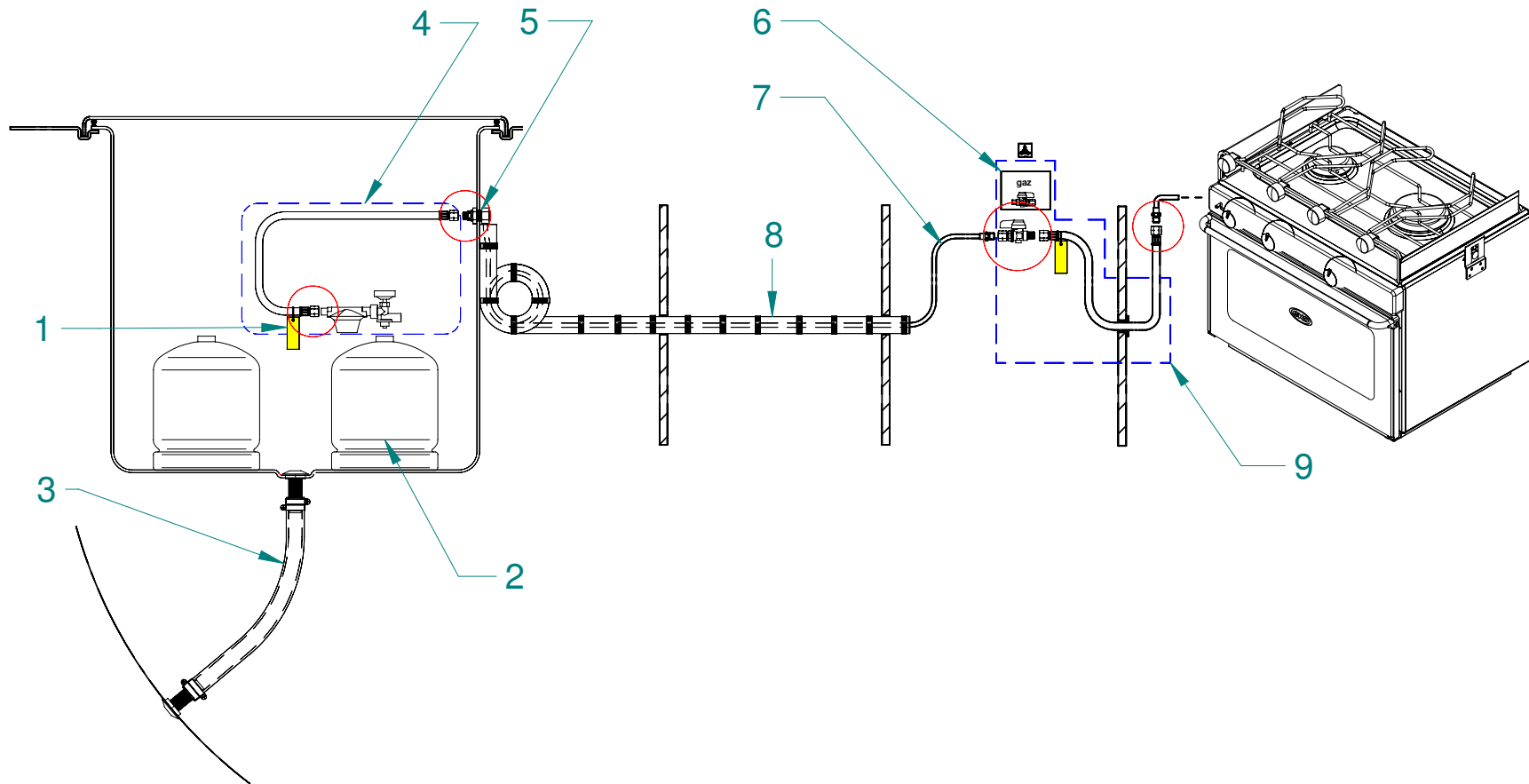

REF	Designation
1	Regulator valve
2	Gas cylinder
3	Drain
4	Connection kit gas bottle
5	Rubber washers
6	Pictogram
7	Connection kit gas copper
8	PVC girdled sleeve
9	Gas appliance connection kit

Safety 2

Regularly check and replace the rubber tubings that link the cylinder to one end of the circuit and the stove to the other one, depending on the norms and regulations in force in your country.

Pay particular attention to keep in good condition the screw thread of the cylinder on which the regulator is. Check the condition of the regulator every year and change it if necessary. Use regulators identical to the ones that are fitted.

Have the repairs carried out by someone skilled.

POSITION OF GAS BOTTLE

The locker for storing gas bottles can be reached through the cockpit. The locker can accommodate 2 gas bottles. The locker is equipped with bottle fastening straps.

■ FIGHT AGAINST FIRE.

It is the owner's or the skipper's responsibility:

- To have the extinguishers checked in pursuance of the instructions given.
- Use extinguisher replacements with equivalent features (same capacity and fire resistance) if the ones in place are out of date or have been used.
- To tell the crew:
 - where the extinguishers are and how they work,
 - where the release aperture is situated in the engine compartment,
 - where the emergency exits are.
- Make sure the extinguishers can be reached easily when people are on board.
- Make sure that the ventilation openings in the engine (and generator, if installed) compartment are well cleared.

Keep the bilge clean. Regularly check that there is no fuel or gas vapour.

For protection of the deck, the vessel owner/user should provide at least one fire bucket complete with rope in an immediately accessible position.

Do not store combustible materials in the engine compartment.

If non-combustible materials are stored in the engine compartment they must be secured so there is no danger of them falling on machinery and they do not obstruct access to and from the compartment.

Always fasten the curtains open when the gas cooker is working.

Exits other than the doors and hatches of the main companionway, equipped with permanently fitted ladders, are identified with a symbol.



WARNING

- Keep an extinguisher handy in case the fire should start again.
- Fire fighting equipment (portable extinguishers, fire blankets and buckets) must be permanently and immediately accessible.

SCHEMA GAS - VERSION US

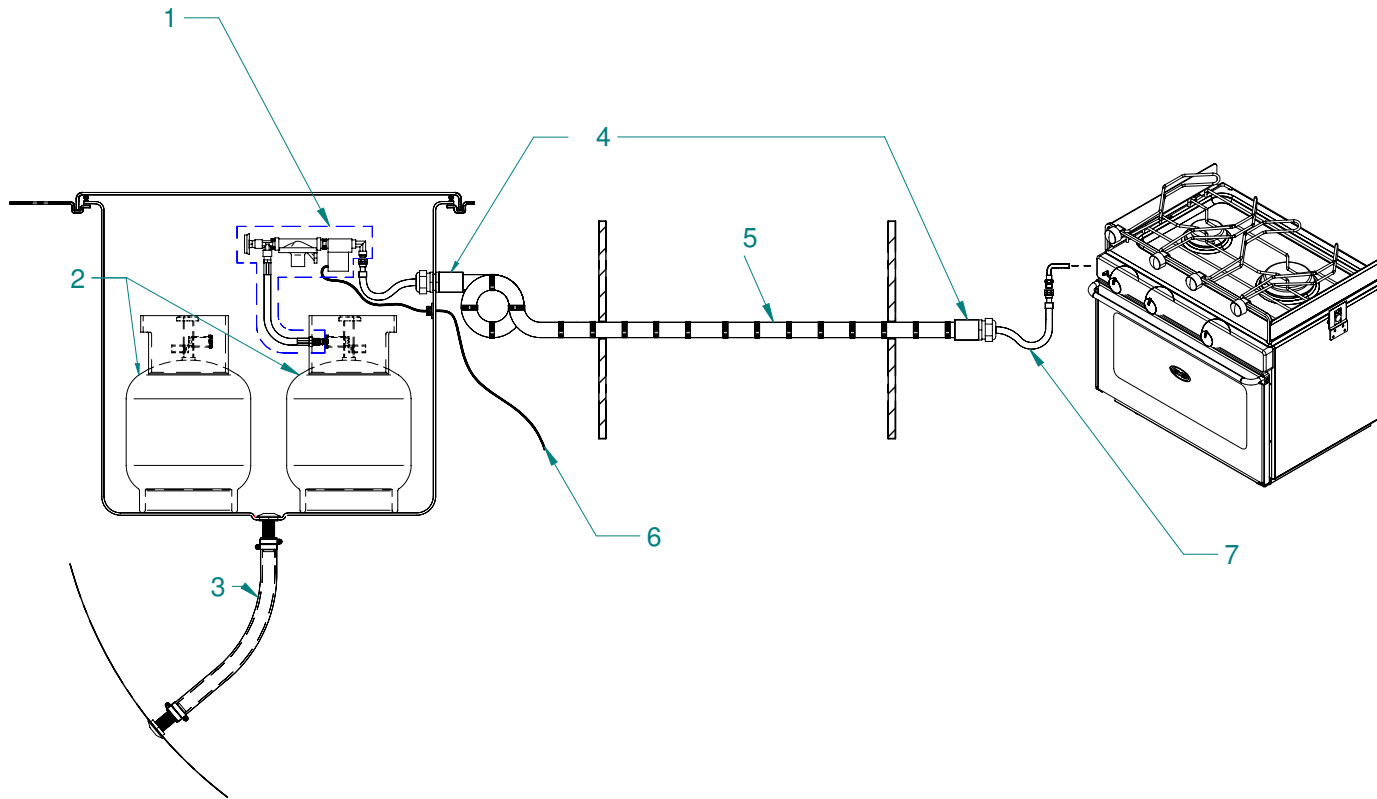

REF	Designation
1	Regulator valve 12V
2	Gas cylinder
3	Drain
4	Stuffing box
5	PVC girdled sleeve
6	Electromagnetic valve for gas 12V
7	Pipe Propane Plastic

Safety 2

EMERGENCY EVACUATION AND LOCATION OF EXTINGUISHERS



 Emergency exits in case of fire

Step - Exits - Forward cabin

- Deck hatch of the fore cabin
- Companionway

Note: Same position for the other layouts.

Position of portable extinguishers (not supplied)



Deck

- Cockpit locker



Version 2 cabins

- Forward cabin closet
- Aft cabin closet to starboard
- Galley



Version 3 cabins

- Forward cabin closet
- Aft cabin closet to starboard
- Galley



Version 4 cabins

- Forward cabin closet
- Aft cabin closet - Starboard
- Galley



Version 5 cabins

- Forward cabin closet - Port side
- Aft cabin closet - Starboard
- Galley

Safety 2

EXTINGUISHERS

The extinguishers are part of the compulsory equipment.

An extinguisher or a fire blanket shall be set less than 2 m from any flame appliance.

Extinguishers must be placed less than 5 m from any berth.

It is compulsory for an extinguisher to be placed less than 2 m away from the extinguisher aperture of the engine compartment.

An extinguisher shall be less than 1 m from the steering station.

The extinguishers must be in position (see "Extinguisher positions" diagram).

Extinguisher, per unit, minimum capacity 5A/34B.

For the model OCEANIS 48: 20A/136B (equivalent 4 extinguishers of this minimum capacity).



DANGER

-There may be danger of fire or explosion if direct or alternating current systems are incorrectly used (Refer to chapter Electricity).



WARNING

- Do not obstruct the ways to the emergency exits.
- Do not obstruct the safety controls (fuel oil valves, gas valves, power switches).
- Do not block the extinguishers placed on shelves.
- Do not leave the vessel unattended when a cooker or heater is in use.
- Do not use gas lamps in the vessel.
- Do not alter the vessel systems (electrical, gas or fuel).
- Do not fill up a tank or change a gas cylinder when an engine is running or a cooker or heater is on.
- Do not smoke while handling fuels or gas.



WARNING

- The **CO²** extinguishers shall be used only to fight **electrical fires**.
- Clear the area immediately after use in order to avoid suffocation.
- Air before entering.

POSITION OF FUEL VALVE AND ENGINE COMPARTMENT EXTINGUISHER APERTURE



Supply valve - Fuel



Extinguisher hole located under the companionway step



A pictogram helps to locate it easily



Port tank



Starboard tank (Extra tank)

Note: Same position for the other layouts.

Safety 2

The engine compartment has a port that makes it possible to inject the extinguishing product inside without opening the usual access hatches.

INSTRUCTIONS TO FOLLOW IN CASE OF A FIRE IN THE ENGINE COMPARTMENT BILGE:

- Stop the engine.
- Switch off power and stop fuel supply.
- Block off the air supply from the air inlets and outlets of the engine.
- Inject the extinguishing product through the aperture.
- Wait.
- Open the access hatches and repair.

USE OF THE MANUAL BILGE PUMP



Location



**Location - Arm - Pump
Starboard cockpit locker**



**Operation
Capacity: 0,7 l / minute**

Safety 2

.... ■ BILGE PUMP SYSTEM.

MANUAL BILGE PUMP

The manual bilge pump is in the cockpit.

The control arm of the pump shall be kept accessible whatever the circumstances.

PROCEDURE TO BE FOLLOWED

- Switch on power to the electric bilge pumps.
- If necessary activate the manual pump.
- Identify the source of the leak by tasting the water and decide on the relevant action to be taken:
 - freshwater = watertank leak.
 - seawater = breach of hull.

ELECTRIC BILGE PUMP

Electric bilge pump aft: Location: In the sump well.

Forward electrical bilge pump: Location: Under - Bow thruster.



Electric bilge pump aft
Location: Sump
Capacity: 46 l / minute



Forward bilge pump
Location: Under - Bow thruster
Capacity: 30 l / minute

Operation:

The electric bilge pumps are connected to the 12V service circuit. To enable operation the 12V circuit must be activated by turning on the battery switches.

You can energize the electric bilge pump from the electrical panel.

On the electrical panel - three possible positions : OFF / Automatic / Mechanically operated.

In the automatic position each pump is set off automatically by a trip switch located in the sump area or in the bottom of the hull.



WARNING

- The bilge pump system is not designed to provide buoyancy to the boat in case of damage.
- The bilge pump system is designed to drive out the water being either sea spray or leaks but absolutely not the water coming through a hole in the hull, this hole being the result of a damage.
- Do not let the pumps run while dry, this may cause them damage.
- The water in the bilge shall be kept at its minimum.
- Check the functioning of each bilge pump regularly.
- Let open the floodgates navigation



SAFETY PRECAUTIONS

- Clean off debris which could block the pump intake points or strainers. If the watertight partitions which seal off the fore and aft points are fitted with valves they must be closed at all times and only opened to drain water into the main bilge.
- Let open the floodgates navigation (Bilge pumps draining).

USE STEERS FRANK OF HELP



Sector access port



Emergency tiller + Tie bar

Safety 2

■ EMERGENCY TILLER.

The emergency tiller is in an aft locker and shall be easy to get to.

To operate the tiller:

- Use a winch handle and unscrew the tiller cover situated at the back of the cockpit.
- Insert the tiller into the rudder stock and make sure it is fully secure in the square.
- If the automatic pilot is connected and is working after the tiller damage, use it.
- Disconnect all apparatus linked to the rudder stock to use the emergency tiller.



ADVICE - RECOMMENDATION

- The emergency tiller is designed only to be able to continue underway at a reduced speed in case of steering gear failure.

Hull

- Maintenance of the Hull
- Lifting
- Keel

LIFTING



Wetted area : 59 m²

■ MAINTENANCE OF THE HULL.

The materials and equipments of your boat have been selected because of their high quality and performance and ease of maintenance. However you shall carry out a minimum maintenance in order to protect your boat from outside attacks (salt, sun, electrolysis ...).

Preferably wash your boat on shore.

Use as few cleaning agents as possible.

Don't use solvents or aggressive detergent agents. Don't discharge cleaning agents into the water.

■ LIFTING.

The lower hull of your boat should be covered with an anti-fouling paint which will prevent the adhesion of marine growth.

The nature of the water in which the boat sails will determine the choice of the anti-fouling paint as well as the frequency of hull stripping and painting. Do not hesitate to take advice from your specialists.

Refer to chapter 11 for launching instructions.

Before applying anti-fouling paint never:

- Do any sandblasting.
- Use any other solvents than ethylic alcohol.
- Use detergents under pressure.
- Use scrapers.
- Do any sanding other than a light rubbing down by hand with a grade 400 wet abrasive paper (to roughen up the hull before the first coat).

If cleaning of the anti-fouling paint has to be done with a high pressure hose:

- The water temperature must not exceed 15 °C.
- The water pressure must not exceed 150 bars.
- The distance between the hose nozzle and the hull must not be less than 10 centimetres.

Follow the supplier's instructions very closely when applying the anti-fouling paint.

All these hull maintenance operations can be carried out by your dealer.



PRECAUTION

- Consult the harbourmaster's office to find out the conditions of water use and the maintenance area for cleaning your vessel.
- It is necessary to seek the advice of your concessionnaire with regard to gel-coat repairs.



PRECAUTION

- When applying the anti-fouling paint do not paint over the electronic instrument sensors nor the anodes.



ADVICE - RECOMMENDATION

- During the refit, check the anodes (See "Motorisation" chapter).
- When the boat is stored at a dry dock, the corrosion protection is not as effective due to oxidation of the anodes: even the new anodes oxidize the surface. Before returning the boat into the water, clean the anodes.
- Cleaning anodes: Use sandpaper. Do not use metal brushes or steel tools to clean the boat, it may damage the galvanic protection.
- Replacing the anodes: The anodes are fastened with screws and nuts. First, remove the screws and nuts that hold the anode, then clean the contact surface. Press the new anode to obtain a good electrical contact.

■ KEEL

General points

The ballast is the appendix located under a sailing yacht. It is an essential component of stability, essential for the operation of the boat.

The ballast is fixed to the bottom of the hull by bolts or pins and nuts with the corresponding tightening torque.

Maintenance

The ballast is a part of the hull under the waterline. It needs to be protected with anti-fouling paint.

Each time the hull is cleaned and each year at least, inspect the condition of the ballast visually together with its joint with the hull. Any fault, crack or burst must be reported to your dealer or a professional who will give you the right advice.

Yearly inspection

Make a visual inspection of all the ballast fixings under the floors. Make sure there are no cracks around the washers, bolts or nuts and that there is no significant corrosion. Any work carried out on these components must be done professionally.

In the event of an incident

In the event of grounding or impact with an unidentified floating object, lift the floors and check that there is no leakage of seawater in the ballast area. Do the same in the area of the rudder mountings.

If there is a leak of seawater, even small, reduce speed and contact the emergency services to follow their advice.

Then take the boat out of the water immediately and have it professionally inspected.

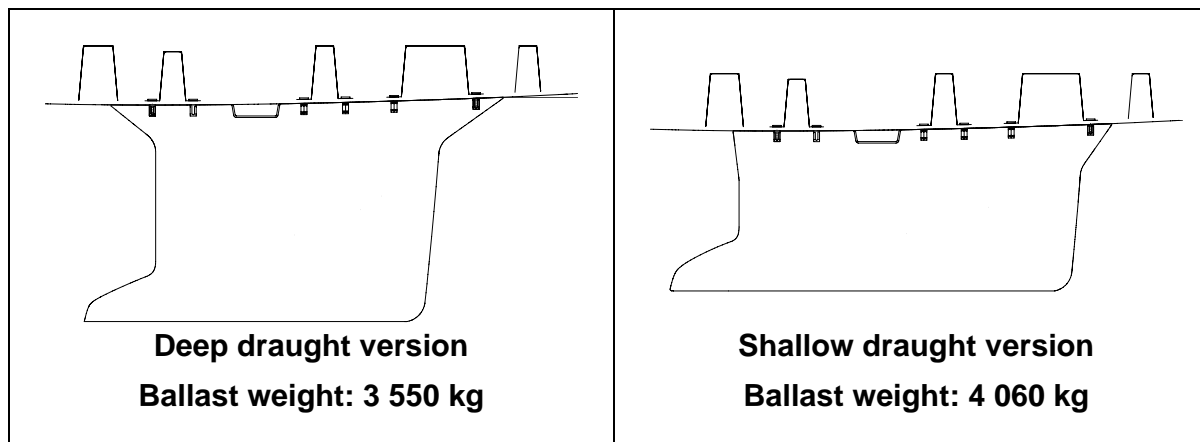

Hull 3

THRU-HULL FITTING - SCUPPERS - LOCATION View - Port side

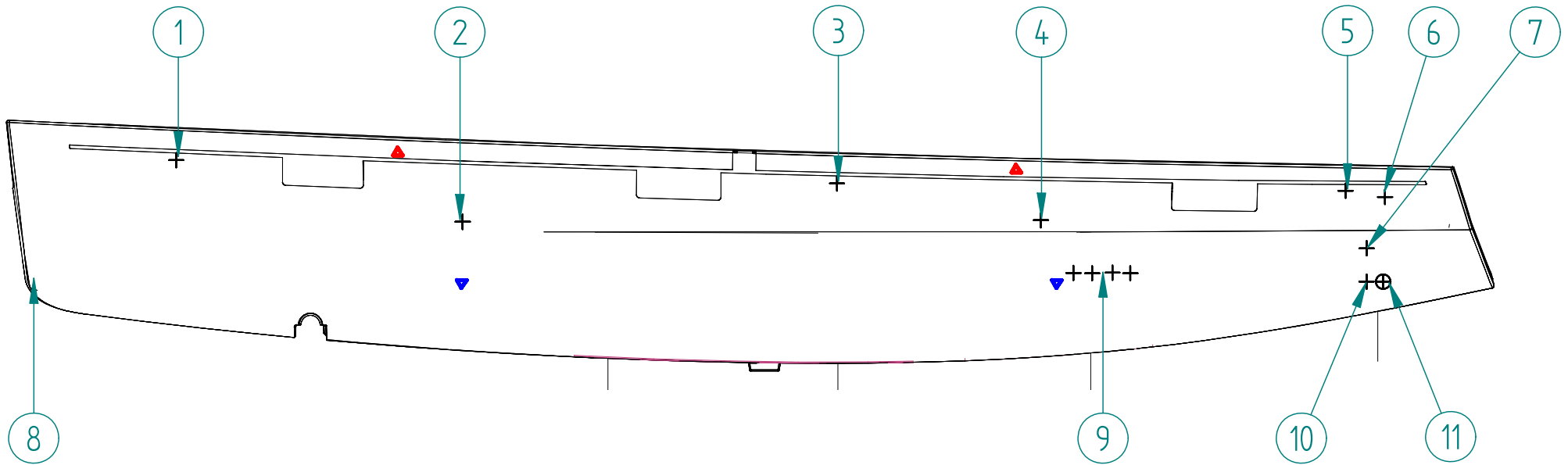

REF	Designation
1	Vent hole - Forward water tank
2	Vent hole - Holding tank (Version 2/3 cabins)
3	Vent hole - Extra water tank (Port side)
4	Vent hole - Holding tank (Version 4/5 cabins)
5	Vent hole - Fuel tank - additional
6	Outlet - Heating
7	Generator exhaust
8	Scuppers - Chain locker
9	Drainage - Air conditioning (x4) (Version 2/3 cabins)
10	Drainage - Generator (Water - Gas separator)
11	Electric bilge pump draining

VIEW - UNDER - FLOATATION (DEPENDING ON VERSION)

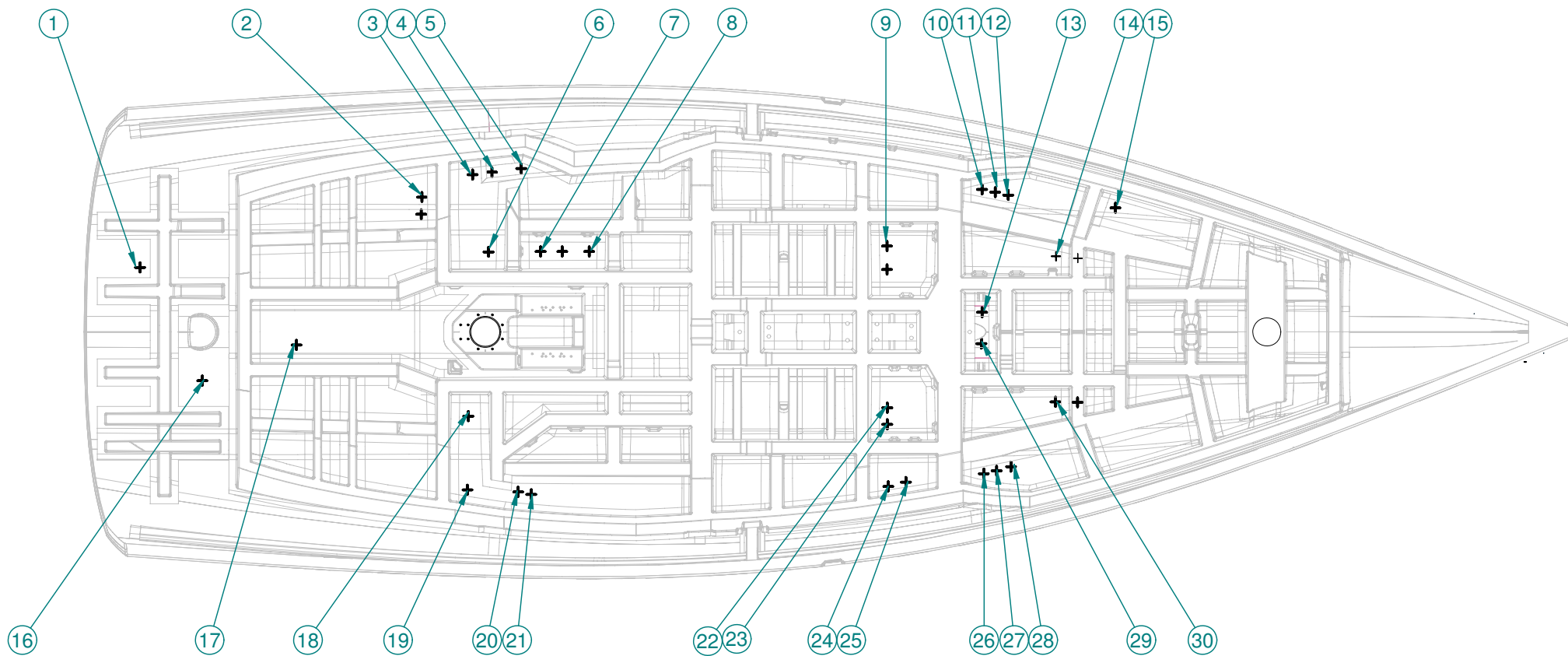

Hull 3

REF	Designation
1	Drain scupper - Compartment - BIB
2	Seawater inlet - WC
3	WC evacuation - to sea
4	Shower draining
5	Bathroom washbasin evacuation
6	Seawater inlet - Generator
7	Drainage - Galley sink / Dishwasher / Cooler
8	Seawater inlet - Foot pump
9	Seawater inlet - Air conditioning
10	WC evacuation - to sea
11	Bathroom washbasin evacuation
12	Shower draining
13	Shower draining
14	Seawater inlet - WC
15	WC evacuation - to sea
16	Exchanger (Fridge)
17	Earthing plate (Generator)
18	Seawater inlet - WC
19	WC evacuation - to sea
20	Bathroom washbasin evacuation
21	Shower draining
22	Seawater inlet - Air conditioning
23	Seawater inlet - Foot pump
24	Icebox drainage
25	Drainage - Galley sink
26	WC evacuation - to sea
27	Bathroom washbasin evacuation
28	Shower draining
29	Bathroom washbasin evacuation
30	Seawater inlet - WC

VIEW - STARBOARD

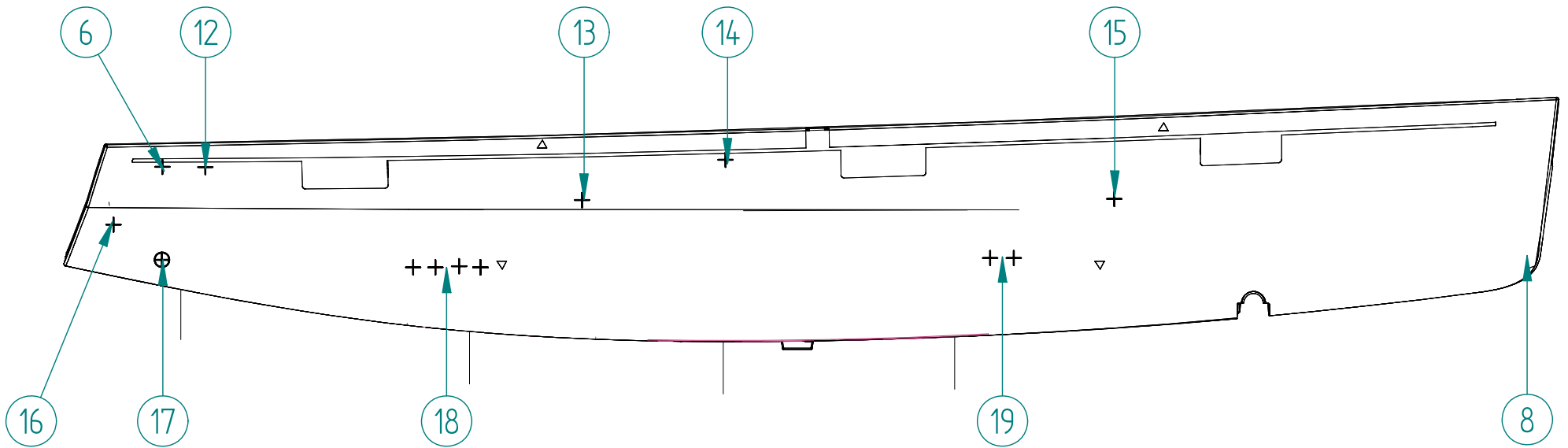

REF	Designation
6	Outlet - Heating
8	Chain locker drain scuppers
12	Vent hole - Fuel tank
13	Vent hole - Holding tank (Version 2/3/4 cabins)
14	Vent hole - Extra water tank (Starboard)
15	Vent hole - Holding tank (Version 4/5 cabins)
16	Engine exhaust
17	Draining of manual bilge pump & electrical
18	Drainage - Air conditioning (x4) (Version 4/5 cabins)
19	Drainage - Air conditioning (All versions)

Deck

- Navigation - Deck Layout
- Stability
- Prevention of man overboard
- Mooring lines
- Towing
- Mooring
- Maintenance of the Deck

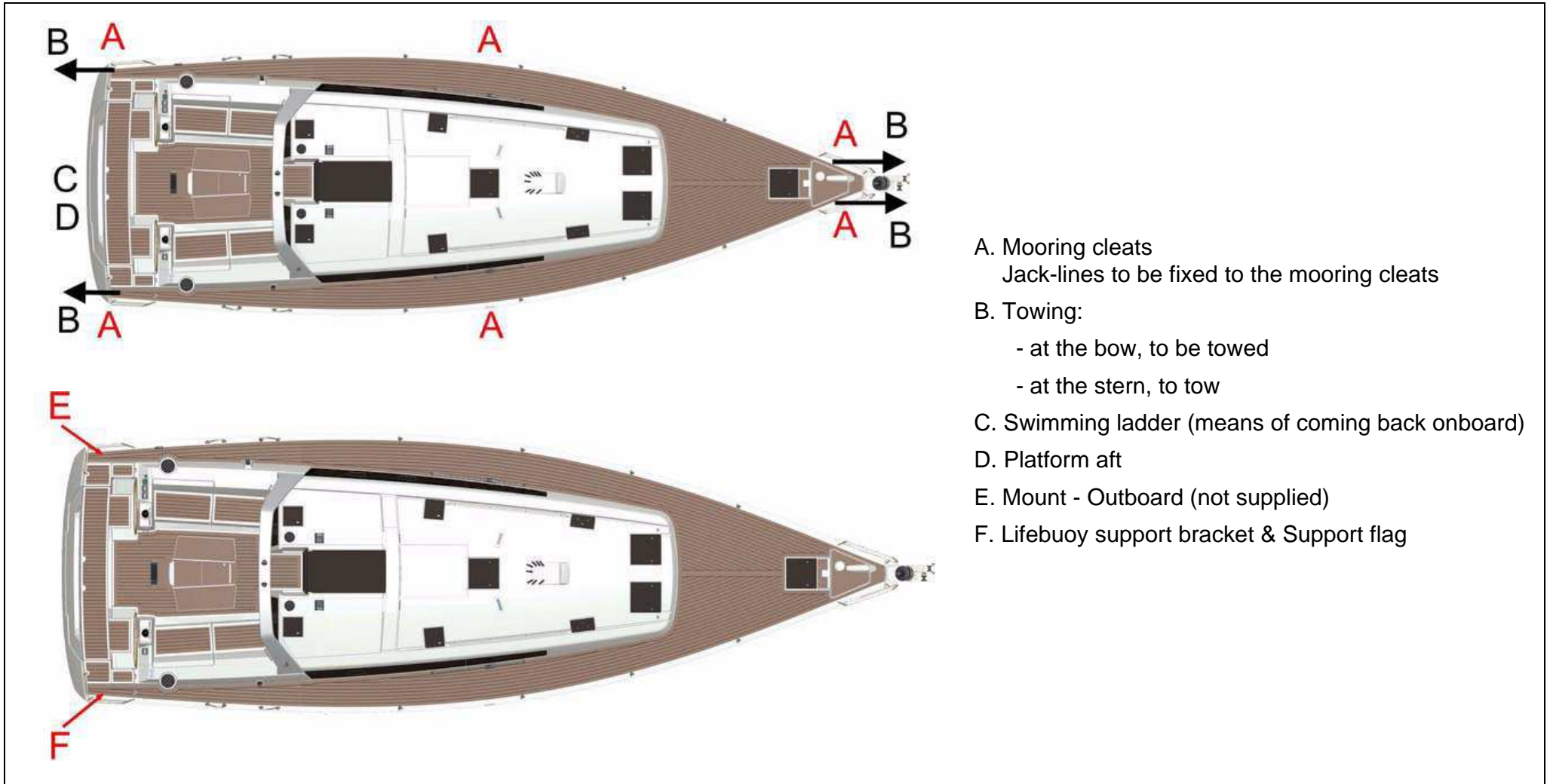

WARNING

-The maximum weight of the outboard engine (not supplied) on the pushpits should not exceed 20 kg.

■ STABILITY.

Breaking waves represent a serious danger for stability and for taking in water. Close the companionway doors and hatches in heavy seas.

During sailing keep all the portholes, windows and doors closed.

- The stability is reduced when you add weight in the upper parts.
- Stability may be reduced when towing a boat or when heavy weights are lifted with the davits.

■ PREVENTION OF MAN OVERBOARD.

Regularly check the guard-rails:

- With metal guard-rails, watch for corrosion particularly at connecting points.
- With synthetic guard-rails, change them as soon as they show signs of wear due to chafing or UV.

Areas forbidden when sailing:

- Aft quarterdeck.
- Roof.

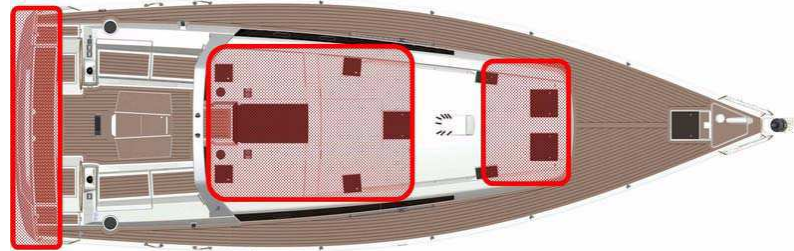

■ MOORING LINES.

A sufficient number of mooring lines suitably sized and suitable for the environment shall be on board for mooring your boat.

- Always manoeuvre your boat using the engine.
- Make allowance for the current and wind when you handle your boat.
- Protect your boat to the highest degree with suitably sized fenders.
- Always keep the mooring ropes unfouled and stored away.
- Handle your boat at a reduced speed.

AFTER MOORING

- Protect the mooring lines against chafing with plastic sleeves.
- Make allowance for the variations in tides if need be.



⚠ DANGER

- Wear your life jacket.
- In heavy weather, wear your safety harness and fasten yourself to the boat.
- When at sea close the guardrail side-opening or openings.
- Do not try to stop the boat using a boat hook or your foot, your hand or any other part of the body.



⚠ WARNING

- The sudden closing of a locker due to a gust of wind or movement of the boat could result in injury.



📌 ADVICE - RECOMMENDATION

- Close the deck hatches and portholes before each trip (including the companionway hatch in heavy weather).

■ TOWING

TOWING BOAT

- Tow another boat at a reduced speed and as smoothly as you can.
- Pay particular attention when you throw or catch the towing rope (it may foul on the propeller).

Note: The stability may be reduced when you tow a boat.

TOWED BOAT

Keep steering your boat and see to it that you stay in the wake of the towing boat. Inappropriate towing can damage your vessel, do not tow at more than 6 knots.

■ MOORING.

As a rule, set the anchor in at least 3 times the depth of water.

ANCHORING WITHOUT WINDLASS

- Have your boat pointed into the wind and without speed.
- Pay out the chain while moving back slowly.
- Once the anchor snags, make it fast by reversing slightly.
- Secure the hawser or the chain to the cleat.

ANCHORING WITH ELECTRIC WINDLASS

- Turn on the boat engine.
- Check that the electrical supply of the windlass is switched on (battery switch, circuit breaker).
- Use the remote control to activate the windlass in lowering mode. Let the chain feed out by keeping the lowering button on the remote control pressed down.
- Let the chain out while moving backwards slowly and as straight as possible.
- Once the anchor snags, make it fast by reversing slightly.
- Secure the hawser or the chain to the cleat.



WARNING

Windlass operations are dangerous:

- Always keep the anchor chain or rode free and unfouled.
- Always proceed with care, using gloves and always wearing shoes.
- If your boat is equipped with the twin control optional extra, make sure you use **only one control** at the same time.



PRECAUTION

- Before anchoring check the depth of water, the power of the current and the nature of the sea bed.
- Anchoring manoeuvres with the electric windlass can only be carried out with the engine running.

Deck 4

Platform - aft

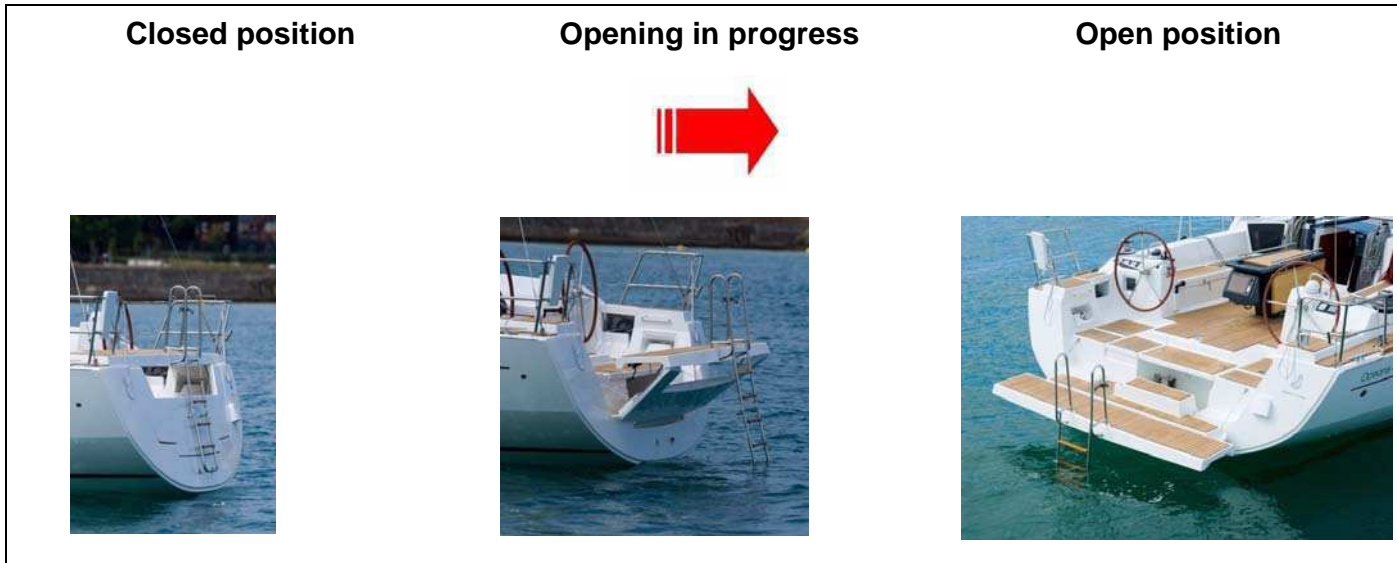

Using the remote control:

Handling and precautions to take are identical to the fixed control. If you control the platform opening from the quay, make sure that the seat is resting properly in the unlocked position.

OPENING Platform:

1. Switch the circuit breaker.
2. Remove the guard-rails from the swimming ladder.
3. Unlock the seat by pulling the point.
4. Push the switch downwards.
5. Wait for the system to stop completely.

CLOSURE Platform:

1. Push the switch upwards.
2. Wait for the system to stop completely.
3. Sit on the bench to lock it.
4. Replace the swimming ladder guard-rails.
5. Switch off the circuit breaker of the relevant apparatus on the electrical panel.



DANGER

- Do not climb onto the platform while in motion.



WARNING

- Do not use the rear platform while sailing.
- Maximum platform load = 300 Kg. (Load must be uniformly distributed).
- During platform opening or closure:
 - Beware of the system movements to avoid injuries.
 - Never leave children unattended when they are using the system.



WARNING

- When you are using the platform remote control, check beforehand that the space in which it operates is completely clear of obstructions and remains so throughout the operation.



WARNING

- Do not let a child operate the platform remote control on his/her own.



ADVICE - RECOMMENDATION

- Before activating the control make sure that nothing will impede the opening or closing
- When not operating:
 - Make sure the breaker is turned off.
 - In upper position: Make sure the helmsman bench is locked.

emergency procedure



In case of electrical failure, you can close the platform manually by following the stages below:

- Shut off the DC supply of the cylinder by the circuit breaker (Starboard aft cabin);
- Remove the protection key from the cylinder body (Ref 1);
- Insert an Allen key to be used as a crank handle. Turn the Allen key manually in the motor until the platform is completely closed.

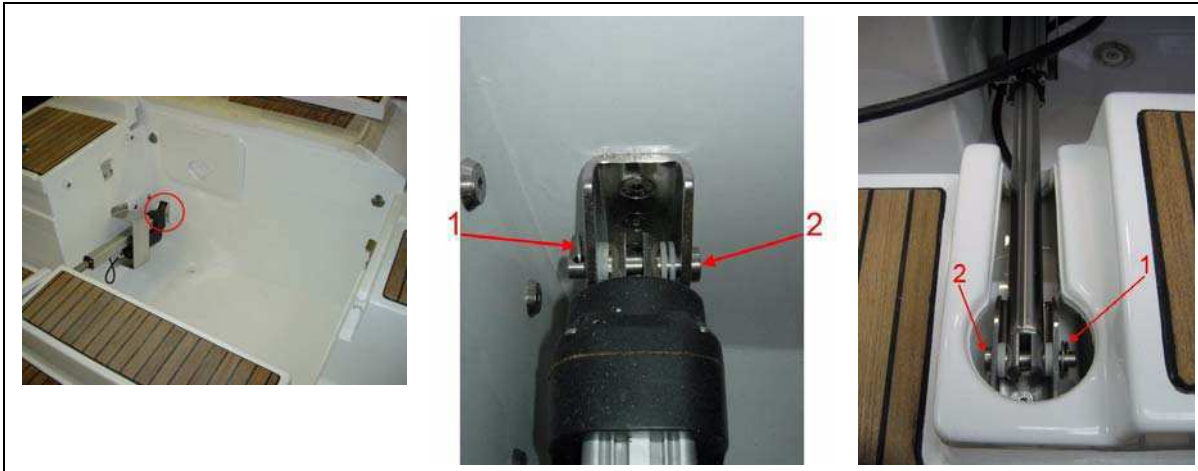

If the cylinder fails, you can close the platform manually by following the stages below:

- Shut off the DC supply of the cylinder by the circuit breaker (Starboard aft cabin);
- Remove the split ring (item 1) and the shaft (item 2) at the two cylinder fixings;
- Remove the platform cylinder and store it in the boat;
- Strike an end on the platform to raise it manually. It is possible to use a winch for this operation.

Deck 4

Folding gangway

General view

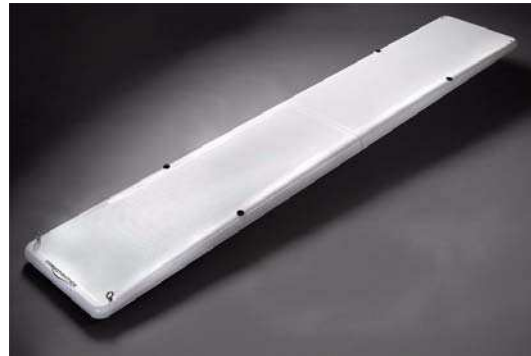
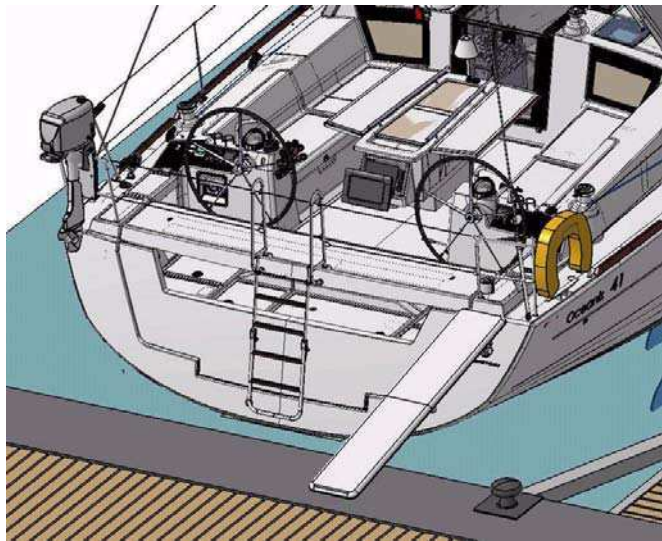
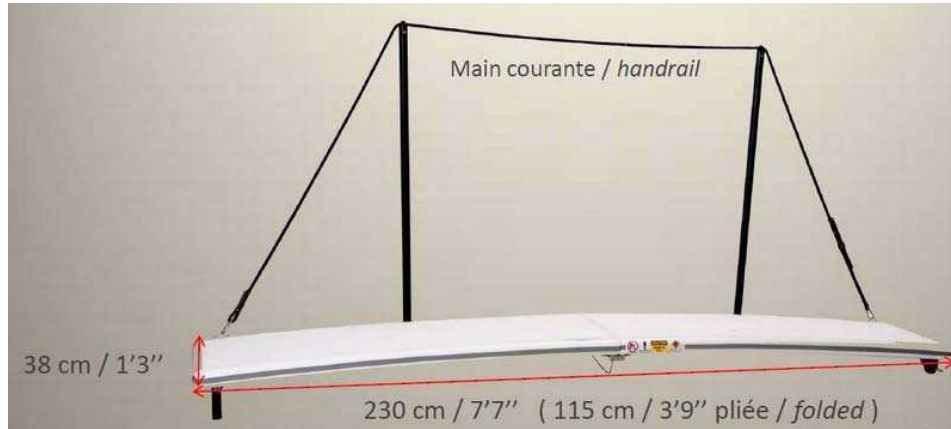

WARNING

- Maximum load permitted on gangway: 300 kg.
- Maximum height difference between boat and quay: 50 cm.
- The gangway must not be used as a diving board.

Locking of the gangway in the horizontal position



1.

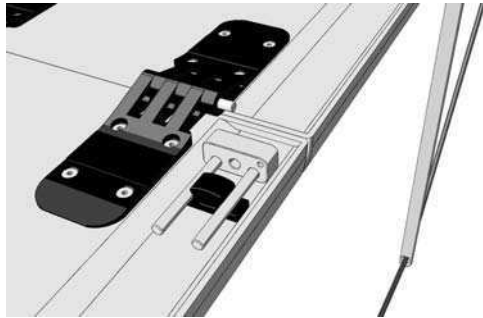

2.

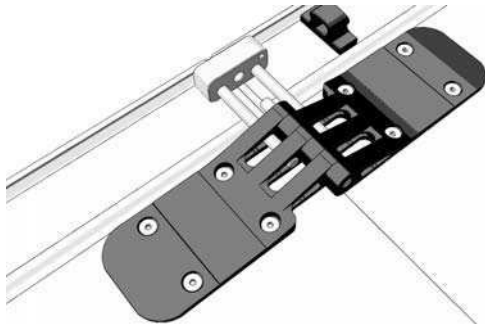

3.

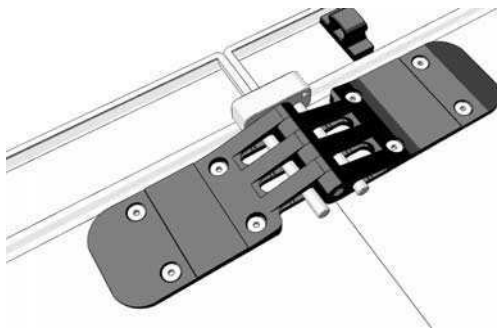

Vertical support

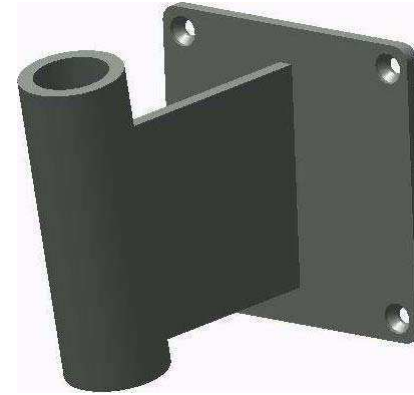

- The gangway is designed for the purpose of allowing embarkation and disembarkation from the boat onto the quay. Any other use is dangerous and forbidden.
- It is essential to lock the hinge mechanism of the gangway in the horizontal position before use.
- The gangway is designed for use by one person at a time only.
- The hand rail is designed only to aid balance when using the gangway. It is not recommended to hang from it or to lean on it.
- The gangway weighs around 8,5 kg.

Deck 4

Closure - Companionway

Opening - Door



Door holding - Closed position



Door holding - Open position



WARNING

Must be secured while sailing.

Cockpit table
Mechanism Opening / Closure



- 1. 12 V socket - Lighting
- 2. Lamp switch

Deck 4

ELECTRIC WINDLASS

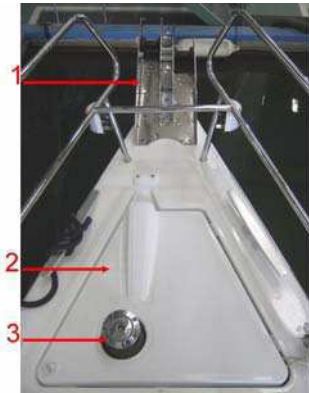

1. Bow fitting
2. Chain locker
3. 12V 1500 W Electric windlass
4. Clinch
5. Chain rim 12 mm diameter
6. Remote control (Forward cargo)

Windlass circuit breaker - 150A
Location: Starboard aft cabin



ANCHORING BY HAND WITH USE OF A MANUAL WINDLASS

- Release the windlass brake using the handle located in the chain locker so as to allow the chain lifter to turn freely and to release the anchor from the stem fitting
- Re-engage the brake and let the anchor hang until the mooring position is reached.
- Have the boat pointed into the wind and without speed.
- Release the brake and pay out the chain slowly.
- Control the speed of anchor lowering using the brake.
- Once the anchor has taken hold re-engage the brake and secure the hawser to the cleat.

HEAVING UP THE ANCHOR

- Lock the cable lifter snubber.
- Ensure the chain is properly set on the cable lifter.
- Slowly go near the anchor, using your engine (Don't use your windlass to winch the boat).
- Heave the anchor completely.
- Visually check the last meters till the anchor gets into contact with the davit.
- If you just change berth, check the position of the anchor on the stem fitting.
- For sailing, store the anchor in the chain locker or fasten the anchor to its roller.
- For electrical windlasses cut off the power supply as soon as the anchor has been lifted.

STERN ANCHORING

Stern anchoring shall be performed with the engine declutched.

- Secure the required length of cablet on the mooring cleat.
- Pay out the anchor line slowly.
- Take care not to damage the propeller or the rudder.



ADVICE - RECOMMENDATION

- After each trip rinse the windlass and anchor chain or rode with fresh water.
- Refer to the manufacturer's instructions for windlass maintenance at the beginning or end of the season.
- Check the swinging area once the boat is at anchor.



ADVICE - RECOMMENDATION

- For sailing with anchor in position:
- Free the chain tension using the windlass before closing the mooring locker hatch.

■ MAINTENANCE OF THE DECK.

Preferably wash your boat on shore.

Use as few cleaning agents as possible.

Don't use solvents or aggressive detergent agents (Refer to chapter 3 "Hull").

Don't discharge cleaning agents into the water.

Regularly brush the deck with a degreasing shampoo and fresh water.

DECK FITTING

- Rinse thoroughly all your equipments with fresh water.
- Periodically lubricate turnbuckles, winches, tracks and travellers with water-repellent grease. Thoroughly and frequently wash off the pulleys and sheaves with clear water.

SOLID WOOD ON EXTERIOR WOODEN PANELLING

Regularly clean the woodworks with fresh water using a sponge (if need be add some gentle soap).

PLEXIGLAS

- Rinse plexiglas with fresh water.
- Use a polish paste for thin scratches.
- Consult your dealer concerning deep scratches.

EXTERIOR CUSHIONS

Bring the removable cushions inside (washed with soapy water then dried) when the vessel is unoccupied.

STAINLESS STEEL

Stainless steel is not incorruptible and requires a minimum of upkeep:

- The use of chrome tools is preferable whenever handling stainless steel.
- Re-nourish the protective film regularly with passivation paste (consult your dealer).



PRECAUTION

- Consult the harbourmaster's office to find out the conditions of water use and the maintenance area for cleaning your vessel.
- Don't use solvent, alcohol, acetone on plexiglas.



ADVICE - RECOMMENDATION

- Use only products similar to the ones that are included in the maintenance case you have been delivered with your boat.
- Don't use a pressure washer.

Steering system

5

- Steering Gear

SCHEMATIC DIAGRAM

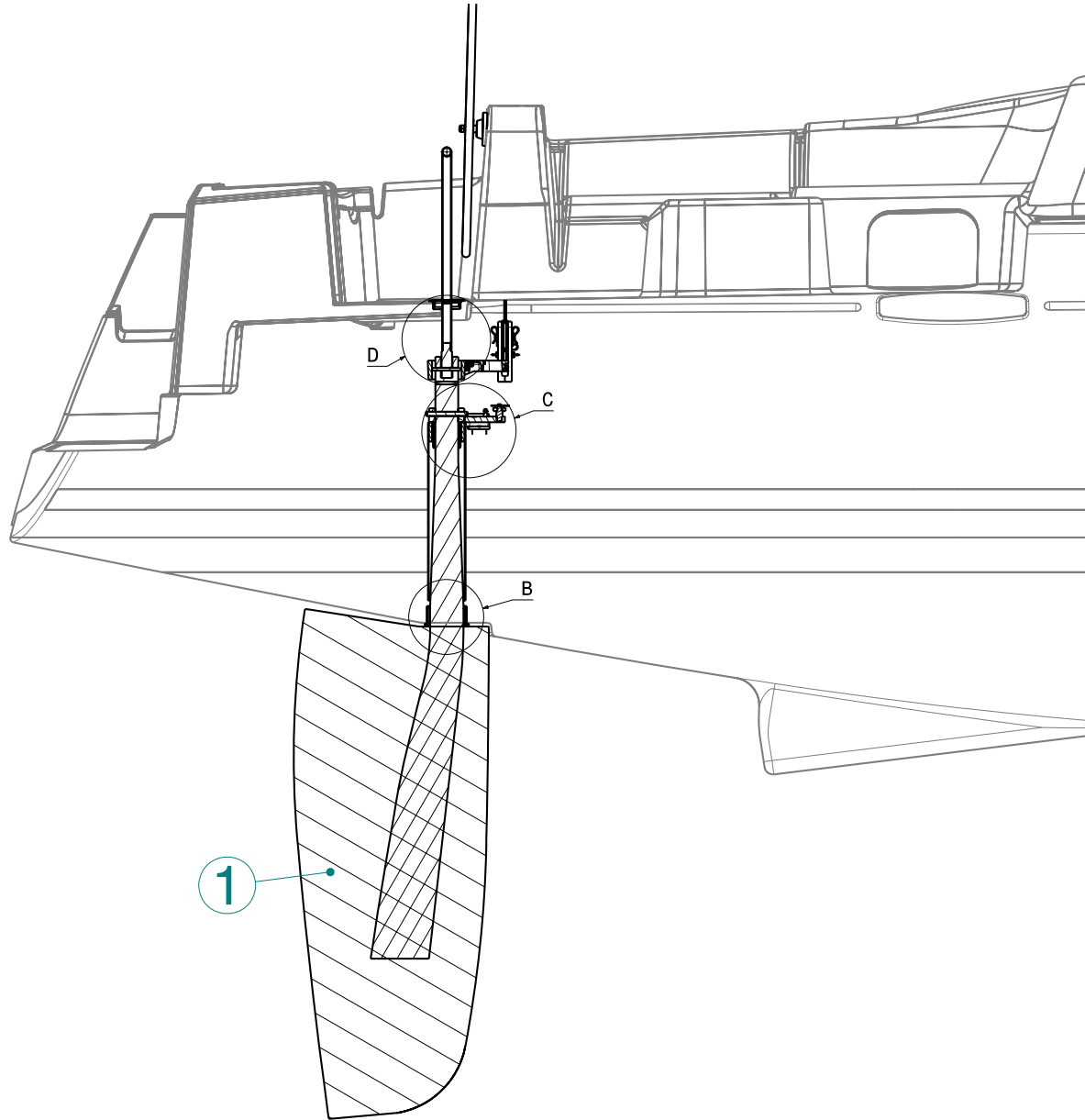

Steering system 5

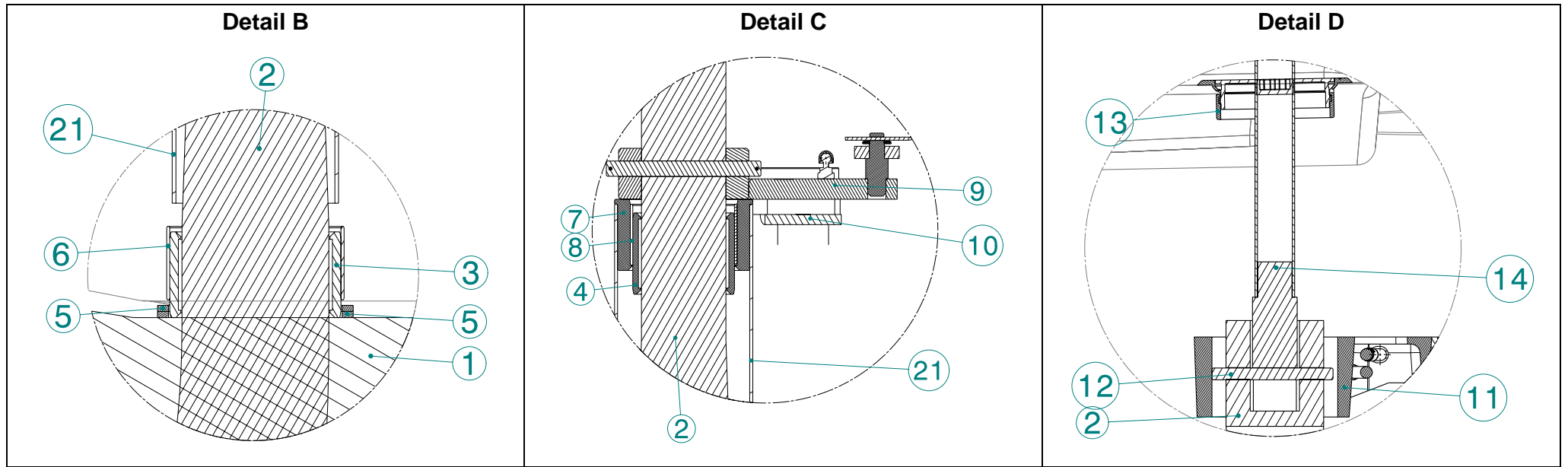

REF	Designation
1	Rudder
2	Rudder stock
3	Collar - Stainless steel - Ø 140
4	Collar - Stainless steel - Ø 100
5	Balance bush
6	Bronze bush - Ø 140x60
7	Bearing - Rudder port tube
8	Bronze bush - Ø 100x60
9	Stock arm
10	Stock arm stop
11	Bored segment
12	Pin - Sector
13	Deck filler - Emergency tiller
14	Emergency tiller
15	Steering wheel - Ø 900
16	Steering column - without brake
17	Steering column - with brake
18	Sheave
19	Chain - Steering Gear
20	Line
21	Rudder port tube
22	Autopilot ram

Steering system 5

■ STEERING GEAR.

CABLE ADJUSTMENT - STEERING SYSTEM

The steering gear is assembled and pre-adjusted at the factory, however, only actual use at sea will enable the steering cable to find its definitive position around the wheel drum.

For this reason, it is necessary to re-adjust the gear after the first few sea outings.

The adjustment is made on the nut and bolt system integral with the steering cable at the join with the profile. To check the adjustment exert a perpendicular force on the cable between the wheel drum and the return sheaves located on the hull.

MAINTENANCE

- Regularly check:
 - The tension in the steering cables.
 - The tightness of the steering system components.
- Don't tighten the steering cables excessively.
- Lubricate all the elements.

Maintain the nylon, ertalon or teflon bushes with only a suitable lubricant.

Note: Do not hesitate to consult your dealer about system maintenance.

**Access to steering gear:
Rear skirt**

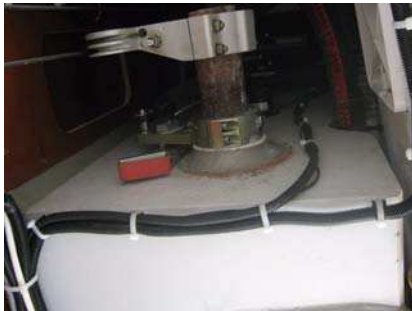

WARNING

- The steering system is a feature of sailing safety and for this reason must be verified at least once a year.
- THE STEERING CABLE MUST BE CHANGED EVERY 10 YEARS.**



WARNING

- Learn how to judge the necessary distance of deceleration for the vessel to come to a complete stop.
- Refer to chapter 2 "Safety" for use of the emergency tiller.



ADVICE - RECOMMENDATION

- The emergency tiller is designed only to be able to continue underway at a reduced speed in case of steering gear failure.

Rigging and sails

- Standing rigging
- Running rigging
- Winches
- Setting the sails
- Sails

DIAGRAM - SAILS

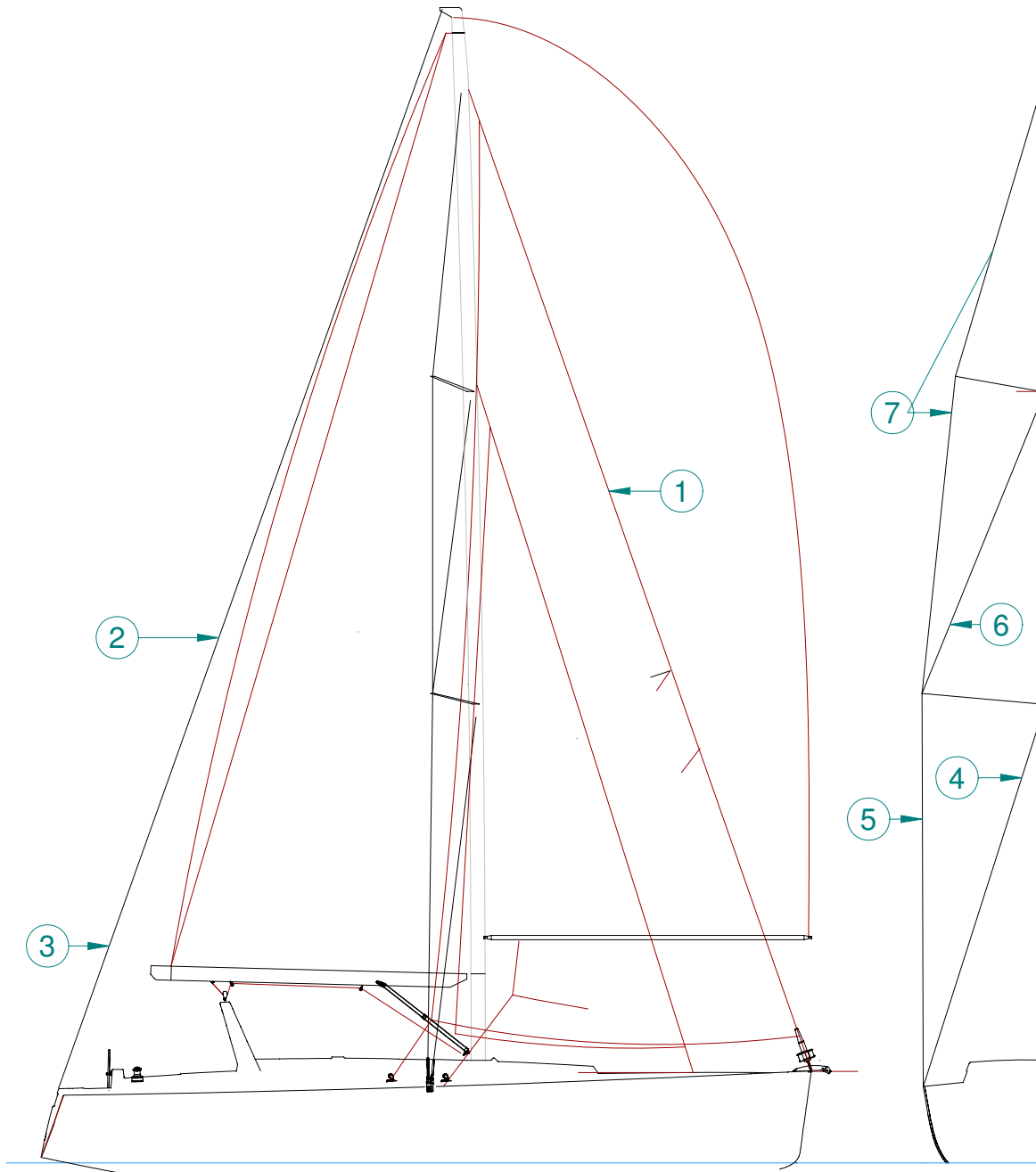

Rigging and sails 6

■ STANDING RIGGING.

Your BENETEAU dealer was responsible for stepping the mast of your boat.

After masting your vessel and after having sailed for the first time it is necessary to seek the help of a qualified specialist in order to carry out a rigging check.

MAINTENANCE

Before each trip, carefully inspect the mast from top to bottom.

Periodically check the rigging tightening and the lock nut or pin locking (you should check it for the first time after a few days sailing in all types of weather).

Secure and lubricate the bottle screws with tallow, graphite grease or other (Never lubricate the bottle screws with silicone).

Check the bottle screw tightening.

Inspect the bottle screws for possible wear (due to the chainplate friction if the rigging is slack).

Change any shroud or stay with severed wires or kinks.

Regularly check the chain-plates for wear.

VERSION: CLASSIC

REF	Designation	Quantity
1	Forestay	1
2	Backstay	1
3	Bridle	2
4	D1	2
5	V1	2
6	D2	2
7	V2D3	2

VERSION: EASY SAIL

REF	Designation	Quantity
1	Forestay	1
2	Backstay	1
3	Bridle	1
4	D1	2
5	V1	2
6	D2	2
7	V2D3	2



DANGER

- To hoist a crew member up to the top of the mast, make a bowline with the halyard directly on the bosun's chair ring (never use the halyard snap shackle or shackle).
- Do not hoist a crew member when sailing in heavy weather.



ADVICE - RECOMMENDATION

- Your dealer BENETEAU can carry out all maintenance operations or recommend a skilled specialist to do so.

RIGGING DIAGRAM (CLASSICAL MAST)

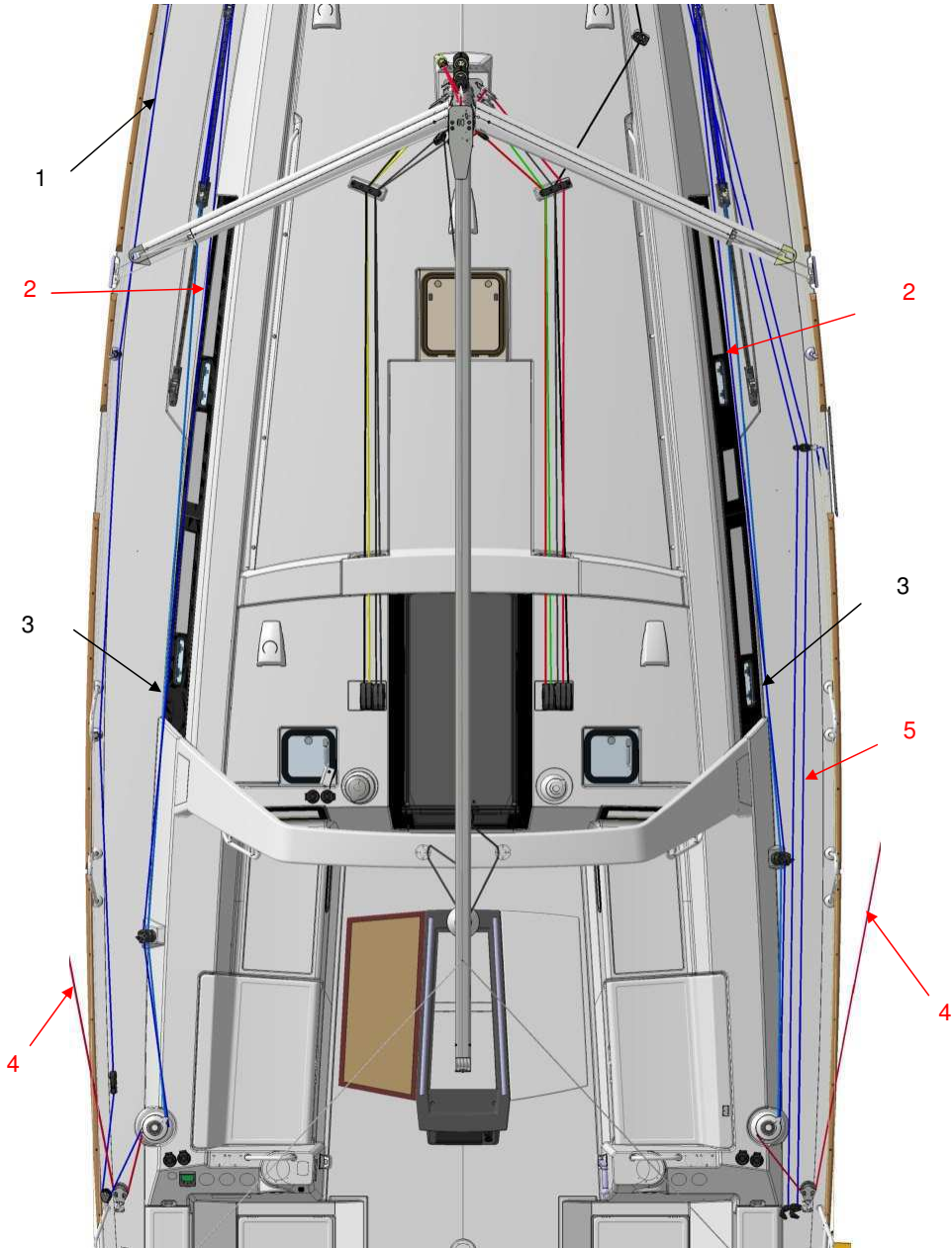

REF	Designation
1	Genoa furler line
2	genoa car adjustment
3	Genoa sheet
4	Spinnaker sheet
5	Furling line - Code 0

Rigging and sails 6

RIGGING DIAGRAM (ROLLER FURLING MAST)

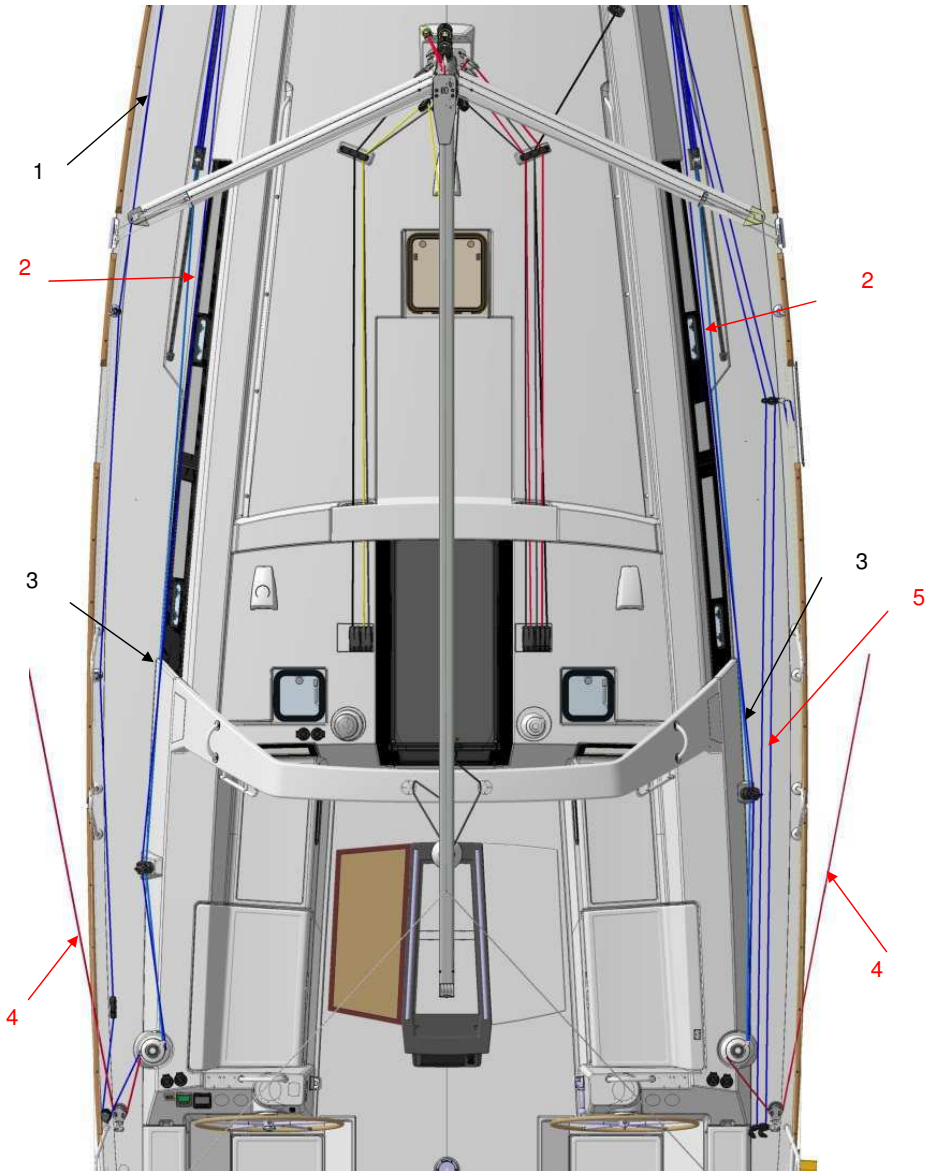

REF	Designation
1	Genoa furler line
2	genoa car adjustment
3	Genoa sheet
4	Spinnaker sheet
5	Furling line - Code 0

■ RUNNING RIGGING.

MAINTENANCE

Lightly grease the sheave pins. Change any distorted or dented sheave. Inspect the pins of the sheaves at the top of the mast once a year.

Regularly check the condition of the jam cleat jaws.

Inspect the halyards for wear and condition.

Regularly clean the pulleys off (old grease, traces of rust) with clear water.

Slightly lubricate the block pins.

Avoid aggressive gybing in order to reduce premature wear on the sheets, attachment points and the gooseneck.

■ WINCHES.

OPERATION

Avoid rope jamming during winch handling. Do not leave loose ropes on the winches but make them fast on cleats (except on the "Self Tailing" winches).

Adjust the winches on receipt of your boat (rinse them regularly during the season).

The winches should rotate freely, they need overhaul as soon as it slightly seizes.

MAINTENANCE

Carry out the complete maintenance of the winches regularly (before and during the sailing season).

- Remove the drums and clean them.
- Lubricate the drums with a film of white grease or Teflon to reduce the friction and fight against corrosion (this type of grease is clean, non toxic and biodegradable).



WARNING

- Refer to the manufacturer's instructions to remove the winches and put them back.
- Improper refitting may result in accidents (e.g. kick of the crank handle).
- A winch drum is designed to have a minimum number of turns necessary so that it does not slip and that the stress is not passed on to the self-tailing mechanism. Make at least 3 or 4 turns on the winch.

■ SETTING THE SAILS.

CLASSICAL MAINSAIL

With the mainsail being on the deck:

- Screw the pins of the mast sliders for battens into their boxes.
- Slide in the battens through the leech.
- Screw the box cap until you get the required tension (the tightening screw shall not project beyond the sail).
- Do not forget the small locking screw.
- Put the mainsail into the lazy-bag.
- Set the boom ring in velcro about level with the clew.
- Fit the mainsail onto its slides, begin with the headboard and finish with the tack.

SYSTEM - MAST STEP (CLASSICAL MAST)

Port side

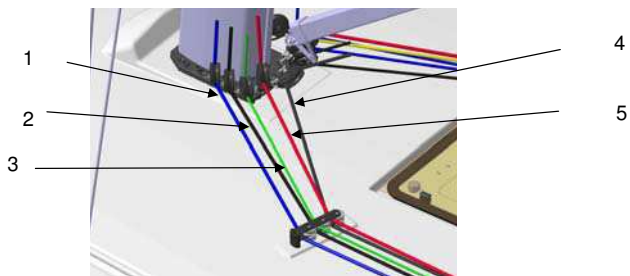

REF	Designation
1	Genoa halyard
2	Main halyard
3	Reef 2
4	Mainsail sheet
5	Mainsail foot

Starboard

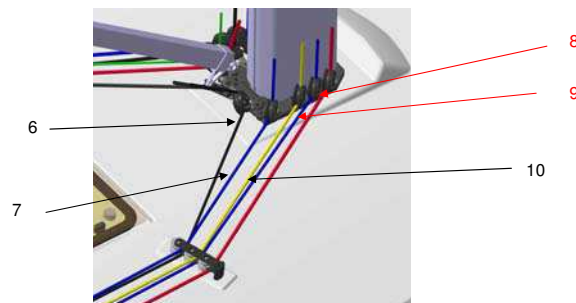

REF	Designation
6	Kicking strap
7	Reef 3
8	Spinnaker halyard
9	Fore stay sail halyard
10	Reef 1

Roof

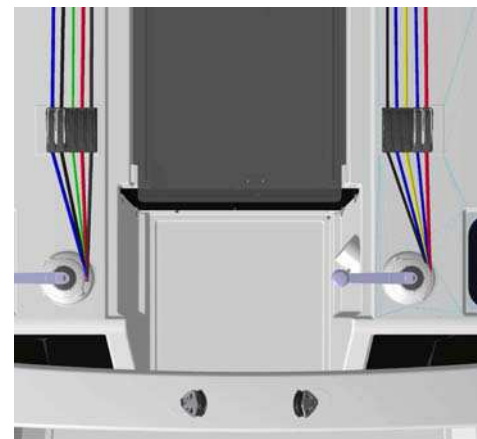

from left to right:

Port side:

Genoa halyard

Main halyard

Reef 2

Mainsail foot

Mainsail sheet

Starboard:

Kicker tackle

Reef 3

Reef 1

Fore stay sail halyard

Spinnaker halyard

Rigging and sails 6

SYSTEM - MAST STEP (ROLLER FURLING MAST)

Port side

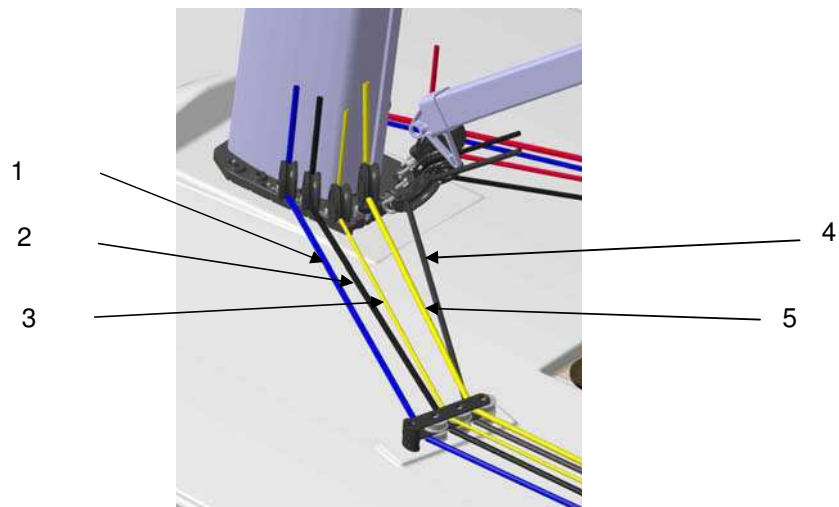

Starboard

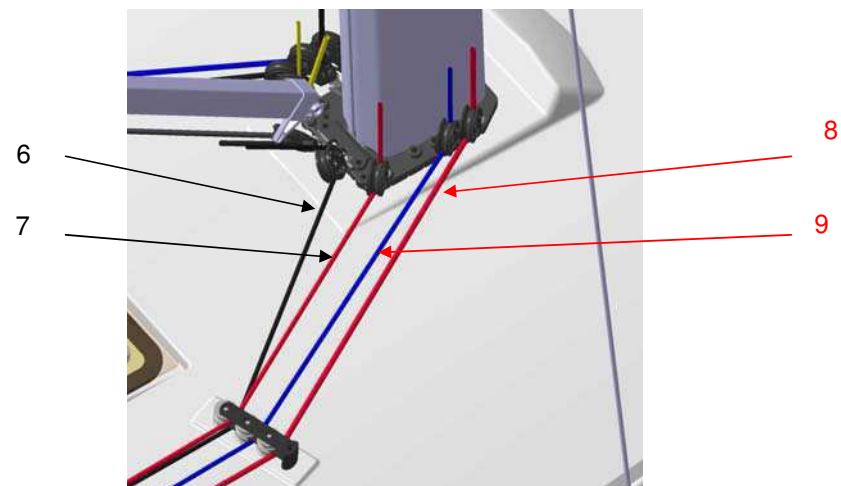

REF	Designation
1	Genoa halyard
2	Main halyard
3	Uphaul
4	Mainsail sheet
5	Mainsail safety block stopper

REF	Designation
6	Kicking strap
7	Mainsail foot
8	Spinnaker halyard
9	Fore stay sail halyard

FURLING GENOA: FITTING

- Secure the head and halyard to the swivel. Secure the tack to the drum and sheets.
- Insert the bolt rope into the hole and hoist it and take care that you do not tear it.
- Have the halyard taut enough but hoist less taut than a sail on a normal stay. Hoist it until the horizontal creases disappear (Adjust the tension of the luff after a few sea trips).
- Pull on the line from the cockpit to furl the genoa.
- Before getting under way take advantage of a windless period of time and hoist the genoa.
- Hand pre-roll the drum to set the furling line on it.

Pay attention to the drum winding direction: The sacrificial strip of the genoa shall be wrapped outside.

Never force it in case it seizes when you furl or unfurl the head sails. Make sure that no ropes are caught in the furler.

MAINTENANCE

- Regularly rinse the drum and swivel.
- Lubricate the bearings if recommended by the manufacturer.
- Remove the sails if your boat is not to be used for a long time.

LAZY-BAG: FITTING

- Spread out the lazy-bag on the deck.
- Slide the battens in and close the batten pockets.
- Hank on the lazy-bag until you have the front part about level with the gooseneck.
- Fasten the lazy-bag to the tack with the strap provided.
- Stretch the lazy-bag from the back before you fasten the lazy-jacks.
- Put the mainsail into the lazy-bag.



ADVICE - RECOMMENDATION

- When you are not sailing, slacken the genoa halyard.
- Install the lazy-bag before the mainsail.
- When the sail is unfurled, adjust the halyard tightness.
- Too much tightness may cause furling problems.
- After taking in a reef for the first time mark the halyard position at the clutch (marker pen or light stitched label) in order to be able to let out the sheet with precision in subsequent manoeuvres.



ADVICE - RECOMMENDATION

- Carry out the complete maintenance of the winches regularly (before and during the sailing season).
- Rinse the winches off regularly during the season.

Rigging and sails 6

SYSTEM - CLASSICAL MAINSAIL

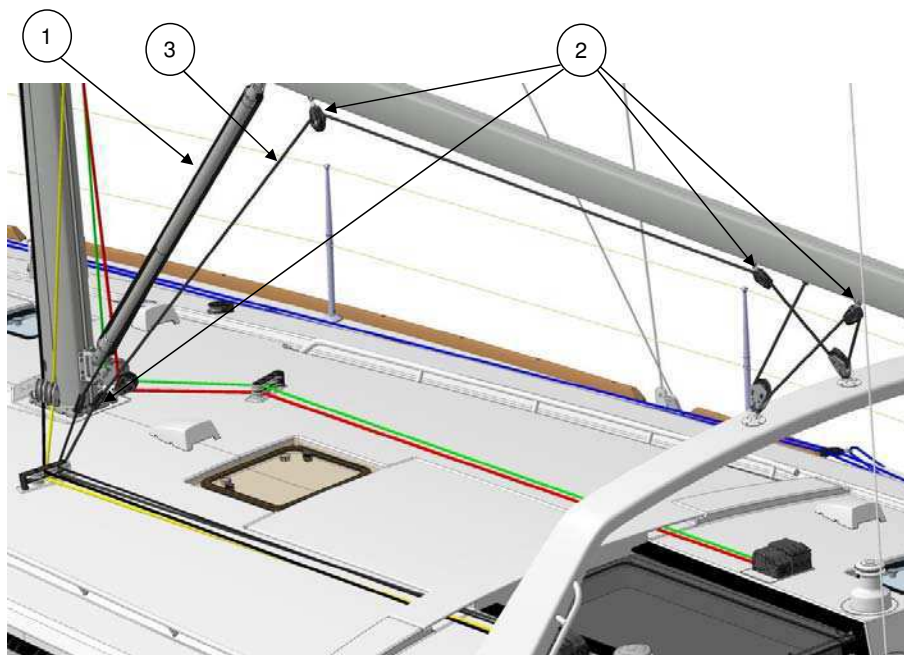

REF	Designation
1	Kicking strap
2	Single pulley
3	Mainsail sheet

SYSTEM - FURLING MAINSAIL

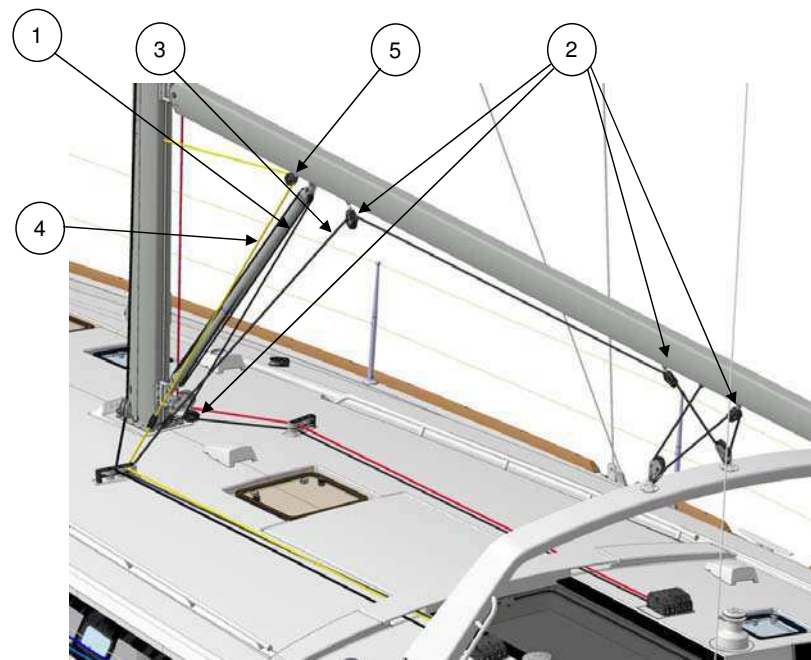

REF	Designation
1	Kicking strap
2	Single pulley
3	Mainsail sheet
4	Mainsail safety block stopper
5	Single pulley

SYSTEM - GENOA

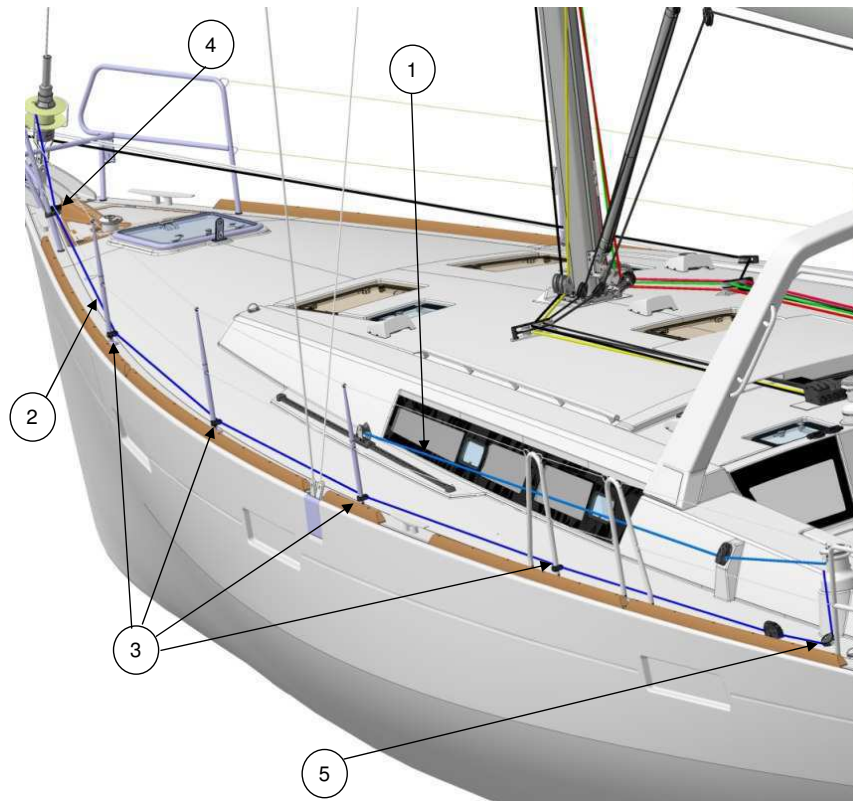

REF	Designation
1	Genoa sheet
2	Mainsail safety block stopper
3	Stanchion fairleads
4	Stanchion block
5	Single pulley

Rigging and sails 6

SYSTEM - ASYMMETRICAL SPINNAKER

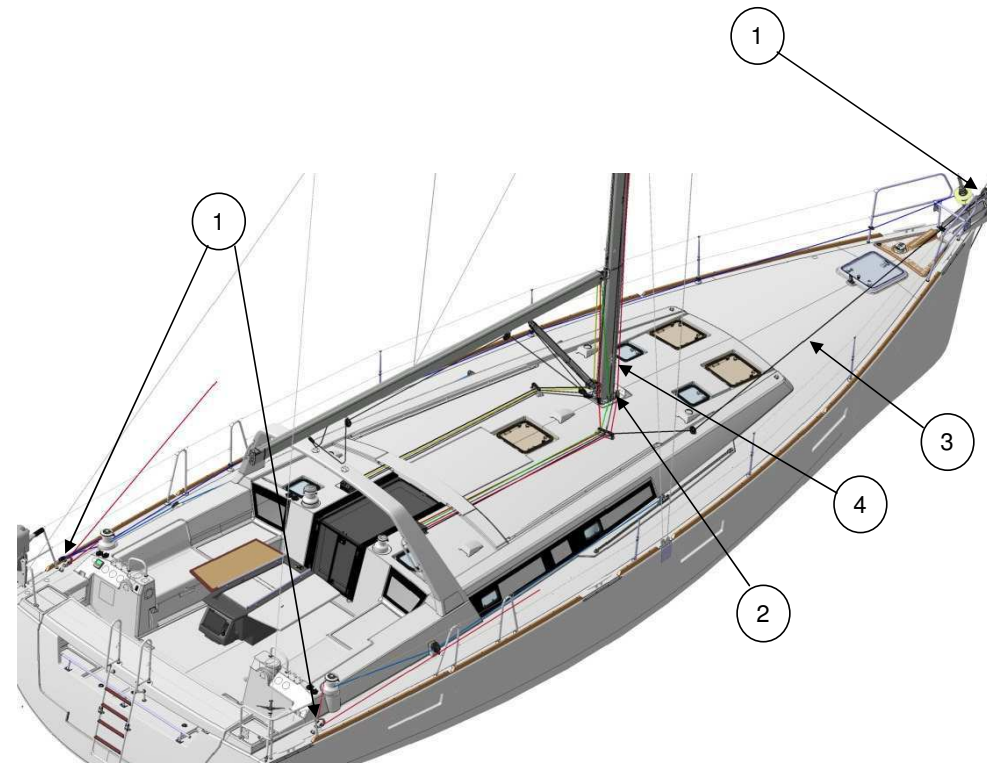

REF	Designation
1	Single pulley
2	Single pulley
3	Spinnaker tack
4	Spinnaker halyard
5	Spinnaker sheet

SYSTEM - EASY SAIL

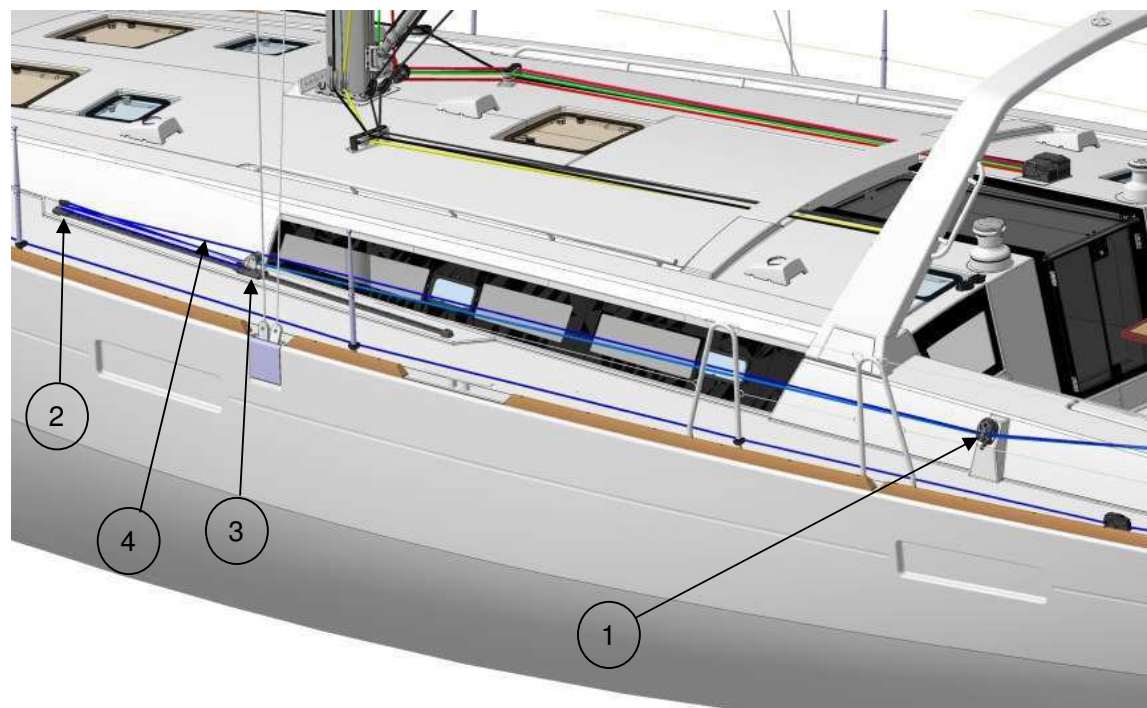

REF	Designation
1	Single pulley
2	Rail end piece
3	Genoa traveller
4	genoa car adjustment

■ SAILS.

The working life of a sail mainly depends on its being regularly maintained.

When sailing, trim the sails properly in accordance with the stresses in order to reduce the harmful strains on the fabric.

Avoid wear and tear: Use protective items against chafing on the the accessories with rough surfaces (protective items for spreaders, stanchions etc.).

Have a sail maker's kit and a user's manual so that you may carry out the emergency repairs waiting for the sailmaker's assistance.

SHORTENING THE STANDARD MAINSAIL

To shorten sail:

- Head into the wind.
- Slacken off the kick strap.
- Slightly slacken the mainsail sheet.
- Slightly slacken the mainsail halyard.
- Take in the reef line.
- Take up the slack in the mainsail halyard.
- Reset the mainsail sheet.
- Take up the kick strap slack if necessary.



ADVICE - RECOMMENDATION

-At the end of the sailing season, and if possible before winter, leave your sails to a specialist to have efficient maintenance and repairs.

CLEANING AND MAINTENANCE

Rinse the sails with fresh water from time to time and dry quickly in order to avoid mildew.

Avoid drying the sails to windward when on the mast (when the sails lift, the seams are worn, the sails may be torn by the rigging).

HAULING DOWN THE STANDARD MAINSAIL

To haul down the mainsail:

- Haul up.
- Slacken off the kick strap.
- Take up the slack in the Lazy bag and uphaul ropes.
- Slacken off the mainsail halyard while taking up the reef lines to control the mainsail descent.
- Fold the mainsail into its lazy-bag.
- Take up the mainsail sheet to immobilise the boom.
- Immobilise the mainsail halyard.

SAIL STORAGE/FOLDING

Avoid storing a wet sail to prevent the appearance of mould and mildew.

Flake the sail parallel to the foot, then roll it up to the bag dimensions.

PROTECTION

UV rays are harmful to polyester and nylon. If the sails remain on the mast, even for 24 h, protect them with a cover or a protection fabric placed on the leech and foot of the furled sails.

Our distributor network offers you accessories that have been selected by the yard and are consistent with your needs.

Rigging and sails 6

SYSTEM - CODE 0

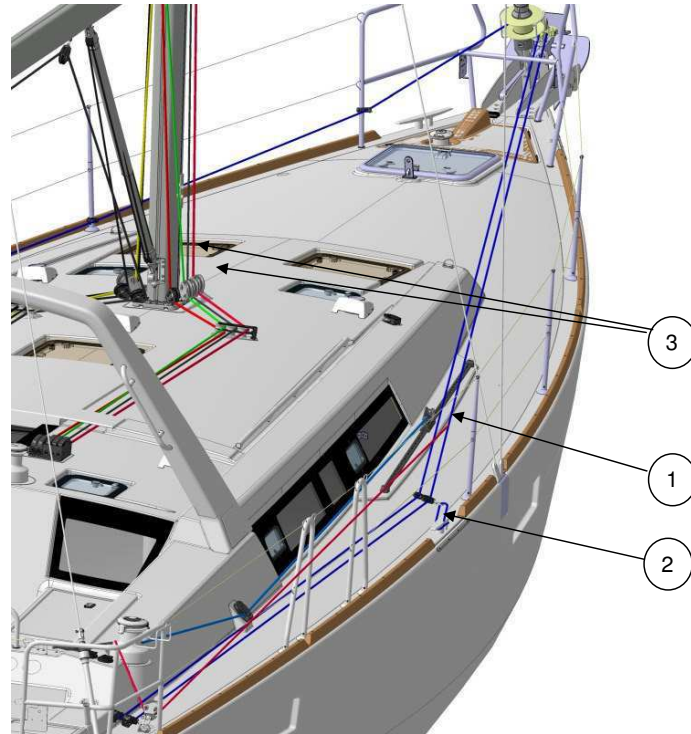

REF	Designation
1	Furling line - Code 0
2	Pig tail
3	Spinnaker halyard - With pulley block

Interior

- Introduction
- Interior maintenance
- Maintenance of fabrics

Version 2 cabins



Version 3 cabins



Version 4 cabins



Version 5 cabins



■ INTERIOR MAINTENANCE.

INTERIOR

- Take advantage of the fine weather to take the settee and berth cushions out.
- Put the cushions vertically if you leave the boat for long.
- Use blinds to protect the inside of the boat against UV rays.
- Carefully remove all crumbs.
- Make sure the bilges are clean and dry.
- Installed in the square of a dehumidifier air leaving the cabin doors and open storage (cupboards, coolers).
- Defrost the fridge regularly/Cool boxes.
- During long absence leave the fridge and icebox doors open to avoid mould developing.

INSIDE VARNISH

- Rinse the inside varnish with fresh water mixed with spot remover and shampoo.
- Polish the interior varnishing with a chamois leather.

■ MAINTENANCE OF FABRICS.

STAIN REMOVAL

- Dab with a clean rag.
- Remove the stain with a solvent poured onto a clean rag. Never pour the solvent directly over the stain.
- Rub with a clean and dry rag.
- Brush the fabric against the grain.
- Use the vacuum cleaner when the fabric is dry.

PVC OR COATED FABRICS

- Use a sponge and water and soap (household soap type).



PRECAUTION

- For the PVC fabrics, don't use any solvent or solvent based product (pure alcohol, acetone, trichloroethylene).



ADVICE - RECOMMENDATION

- Preferably wash your boat on shore.
- Use as few cleaning agents as possible.
- Don't discharge cleaning agents into the water.
- Take the removable upholstery inside when the vessel is not being used.
- Place protective covers/awnings.
- Mark up each cover and foam when dismantling.

100% POLYESTER/DRALON JACQUARD

If you cannot remove the fabric:

- Clean with the vacuum cleaner.
- Clean with a foam for synthetic fabrics (please refer to the product instructions).

If you can remove the fabric:

- Hand wash with an ordinary washing powder at 30° C.

In both cases, dry cleaning is possible. Remove the stains as soon as possible with a damp rag.

COTTON JACQUARD

- Dry clean.
- Do not iron.
- Do not use hypochlorite.
- Remove the stains with fractionated petrol.

ALCANTARA

- Wash in warm water with a neutral pH soap.
- Dry it naturally.
- Dry clean with perchloroethylene.

LEATHER

- Use a leather cream for ordinary care.
- Do not use detergent.
- Do not use silicone based products.
- Clean with a sponge and soapy water.
- Remove ball point pen marks with methylated spirit.
- Remove the grease stains with an absorbent powder (e.g. talcum powder).

Water and sewage water

- Water tanks
- Water system - Distribution
- Water system - Drainage
- Sewage

Forward water tank
Location: Forward cabin
Capacity: 330 litre



Deck fillers

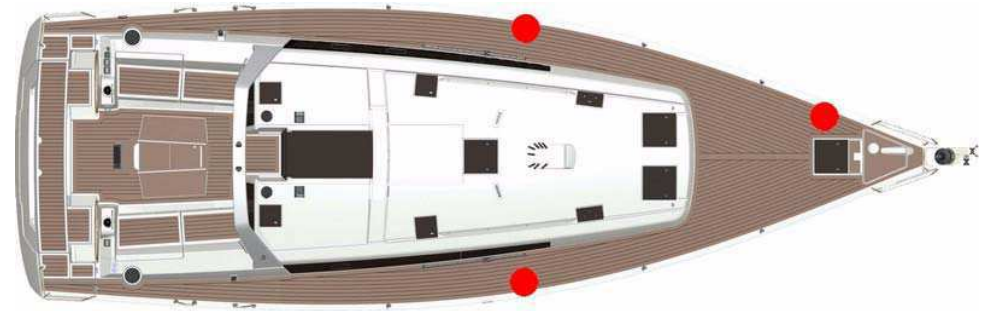

Water tanks - additional
Location: Port saloon & Starboard
Capacity: 2 x 165 litre



Gauge
Location: Electrical panel
Refer to the instructions for use



Correspondence:
Tank 1 = Port saloon
Tank 2 = Starboard saloon
Tank 3 = Forward cabin

■ WATER TANKS.

OPERATION

In order to prevent any handling mistakes, never fill the water and fuel tanks at the same time.

During filling, avoid handling contaminants near the fillers.

Open and close the filler caps with the suitable key.

Check the filler cap seals for condition during filling.

The tanks are fitted with overflow outlets and vents.

Never insert the water filling hose deep down into the system in order to prevent any over-pressure in the systems.



WARNING

-The tanks' nominal capacity cannot be fully used due to the load and the need to maintain the correct trim. A 20% reserve should be kept.



ADVICE - RECOMMENDATION

- Pay attention to the quality of the water for the filling up. Check if it is drinking water.
- It is possible to sterilize the tanks with a Clonazione tablet (sold at the Chemist's).
- If the boat is not used for long, purify the tanks and pipes with acetic acid (or white vinegar).
- For winter storage instructions and precautions, refer to Chapter 12.

PLUMBING BOARD

LOCATION: STARBOARD SALOON



1. Supply valves - Tanks
2. Expansion tank
3. Water pump 12V + Filter

Water heater - 220V
Location: Port aft cabin

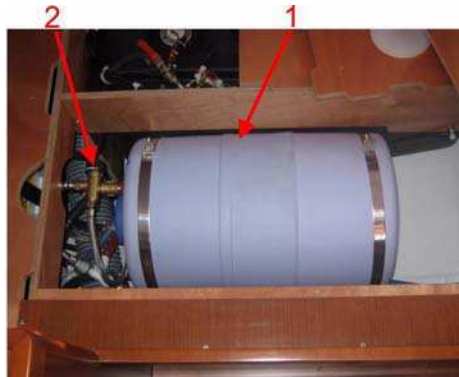

1. Thermostatic mixer valve
2. 40l water heater

Control on the electrical panel



Water and sewage water 8

■ WATER SYSTEM - DISTRIBUTION.

USE OF THE WASHBASINS AND SHOWERS

- Close the valves and turn off the taps after use.

SEA WATER FOOT PUMP

The footpump allows the discharge of seawater or freshwater without activating the water system.

Control



3 way valve
Location: Under the sink



Seawater inlet / House water



WARNING

- Turn off the shore freshwater supply valve before leaving the vessel.



WARNING

- Bleed the cockpit shower circuits and the deck washing pump to prevent freezing.



PRECAUTION

- Never operate the water system equipment when the valve is closed or the tank is empty (the electrical equipment may be damaged).
- Check the water filter for condition (refer to manufacturer's instructions).
- Close the taps of empty tanks.

COCKPIT SHOWER SPRAY

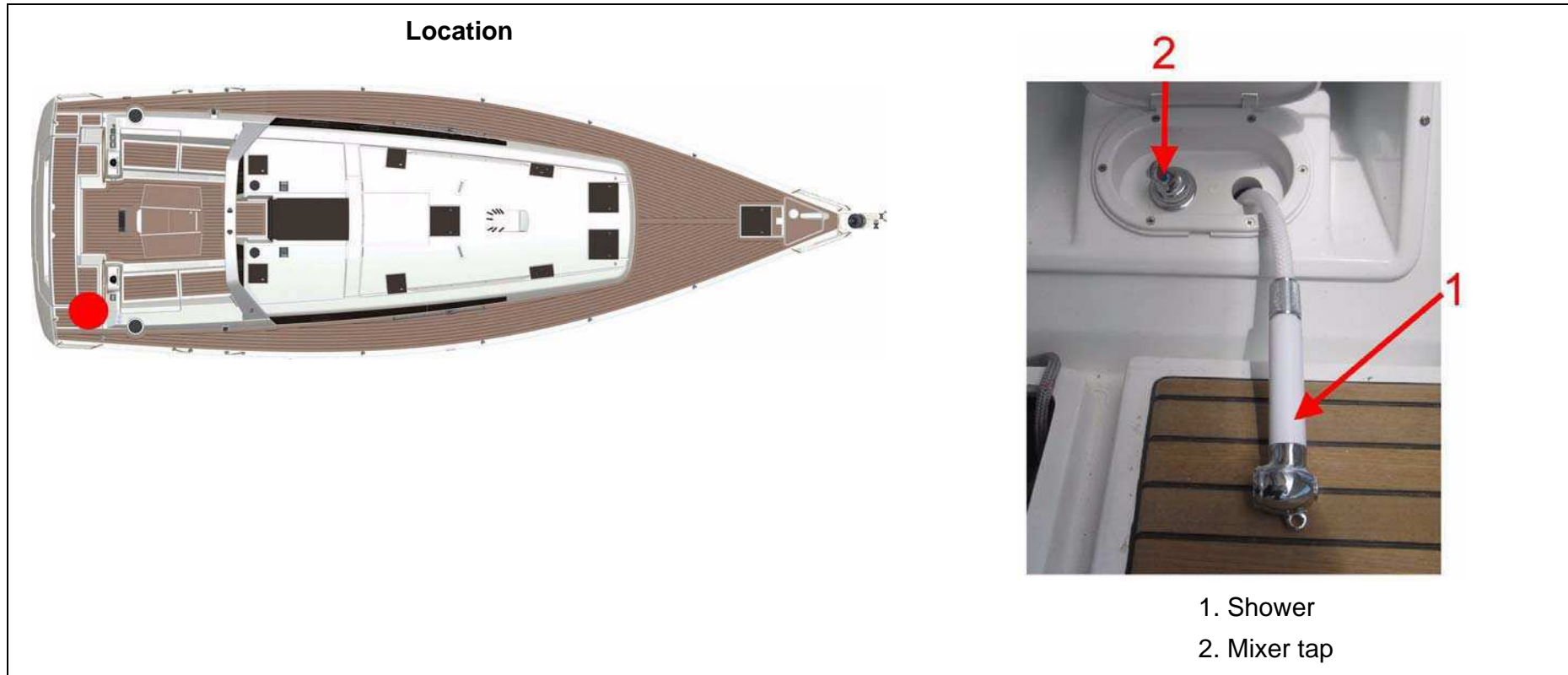

SOCKET - SHORE WATER



WARNING

Always shut off the water shore supply before leaving the boat.

■ WATER SYSTEM - DRAINAGE.

OPERATION

Waste water from the sink, washbasins and heads is drained off by thru-hull fittings with ball valves (the valve is closed when the valve handle is perpendicular to the hose, the valve is open when the valve handle is in line with the hose).

All the floors have holes (limber holes) for the water flow.

A watertight bilge tray under the engine receives the possible oil leaks.

A main sump located above the ballast receives water from the bilges.

The main sump is partially drained by an electric or a manual pump. Regularly dry the sump with a sponge.



ADVICE - RECOMMENDATION

- Regularly check the valves and thru-hull seacocks for proper operation and watertightness.
- Turn off the valves when the water system is not in use.
- Visually check the water pump flow.
- Check the clamps and flexible hose connections for tightness.
- Pay attention to the seals for condition.
- Regularly make sure that the strum box and bilge are perfectly clean.
- Immediately switch off the electric system in case a pump is running while all the water supplies are turned off.
- In case of a leak check the system.

SHOWER DRAINING - STARBOARD - FORWARD

- 1. Pump - Shower draining
- 2. Shower draining

Control - Shower draining



SHOWER DRAINING - STARBOARD - AFT

- 1. Draining pump for shower
- 2. Shower draining

Control

Draining pump for shower



. ■ SEWAGE.

USE OF THE MARINE HEADS

Before you use the heads, check that the water intake valve and draining valve are open.

To empty the bowl:

- Set the control lever of the pump slantwise (FLUSH).
- Operate the pump.

To dry the bowl:

- Set the lever back vertical (DRY).
- Operate the pump.

To avoid blocking the toilets only use absorbent paper in reasonable quantities.

Schedule a regular rinsing through of the heads with fresh water.

Close the valves after each use (in particular when the boat is unattended).



ADVICE - RECOMMENDATION

- When you are in a marina, use the clubhouse sanitary facilities (if there are).
- Since it is prohibited to discharge sewage water in certain marinas or countries it may be necessary to use the foul water holding tank ('WHT').

Kitchen sink drain - Cooler



Sink drainage valve + Cooler
Location: Under the sink



Pump - Cooler + Control



ELECTRIC TOILET

The electric toilets operate with seawater only. A switch enables the water intake and drain cycle of the bowl to be activated. A switch enables the bowl to be rinsed.

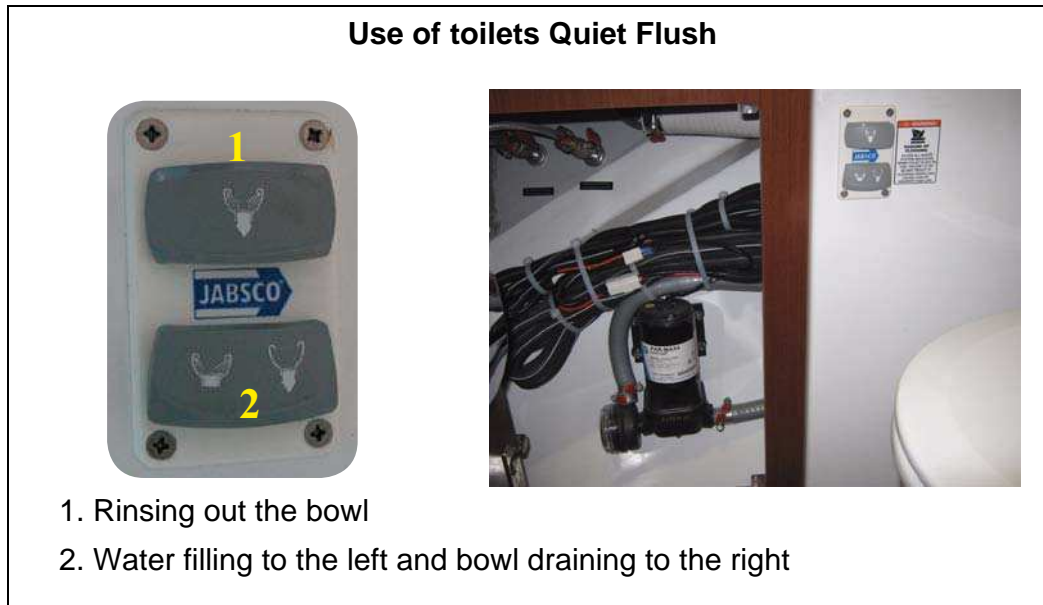

RESPECT OF THE ENVIRONMENT

- Remain informed of local regulations concerning the environment and follow the codes of best practice.
- Do not drain the contents of the sewage tank near the coast or in zones where it is forbidden.
- Make use of the port or marina pump facilities to drain the sewage tank before leaving port.
- Find out the international regulations against marine pollution (Marpol) and follow them as far as possible.



ADVICE - RECOMMENDATION

- Completely empty the black water system before leaving the vessel unattended in temperatures below freezing..



ADVICE - RECOMMENDATION

- To prevent odors caused by organic waste in pipes one should clarify the circuit after each use. For this procedure, drive about ten times the manual pump of the toilet or for a minute if it is an electrical pump
- When you leave the ship for several days, flush the toilets circuit assembly with fresh water. Purify with specific products (for example a health additive to clean, disinfect and neutralize odors).

Black water circuit - Schematic diagram

Deck or sea evacuation

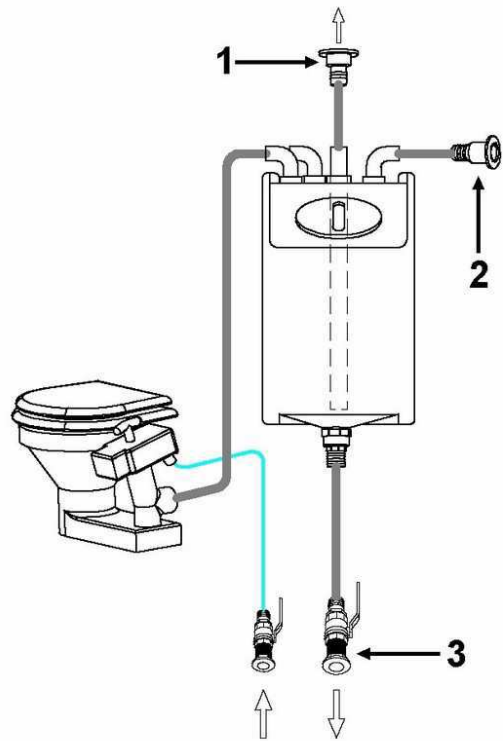

1. Deck filler - Suction and Rinsing
2. Tank vent hole
3. Thru-hull seacock

Deck only evacuation

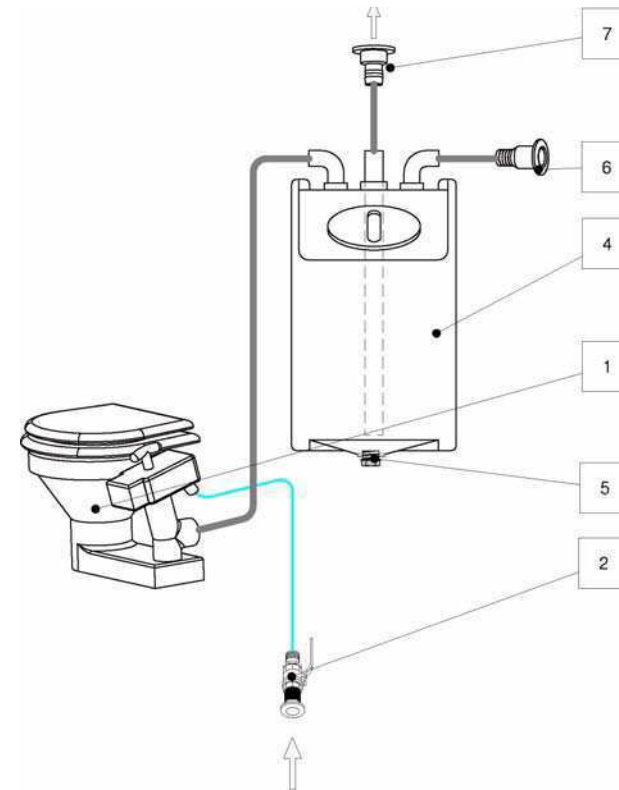

1. WC
2. Seawater inlet
4. Sewage tank
5. Closing cap
6. Vent hole
7. Deck filler: Intake / Rinsing off

Water and sewage water 8

Sewage tank



Capacity: see : Version
1. Tank, 73 l
2. Tank, 64 l

2 cabins



3 cabins



4 cabins

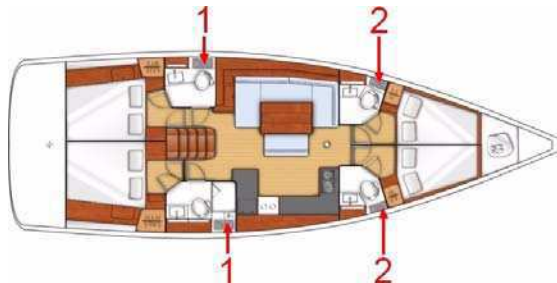

5 cabins

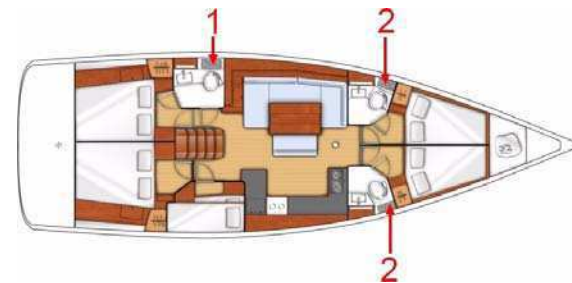

WC evacuation - Deck

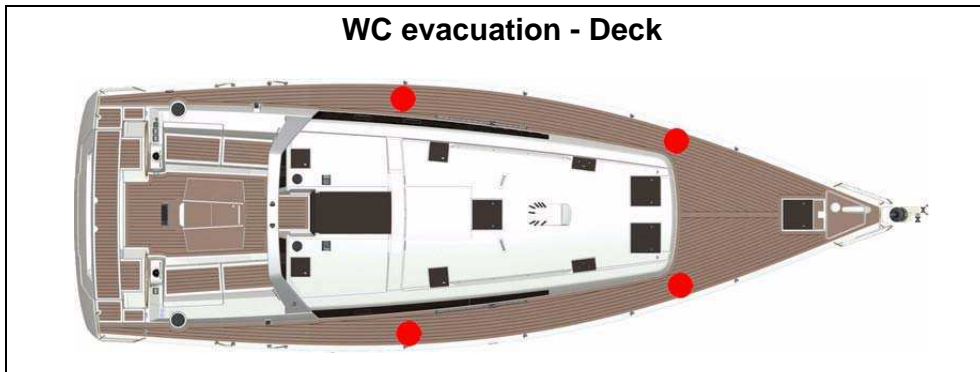

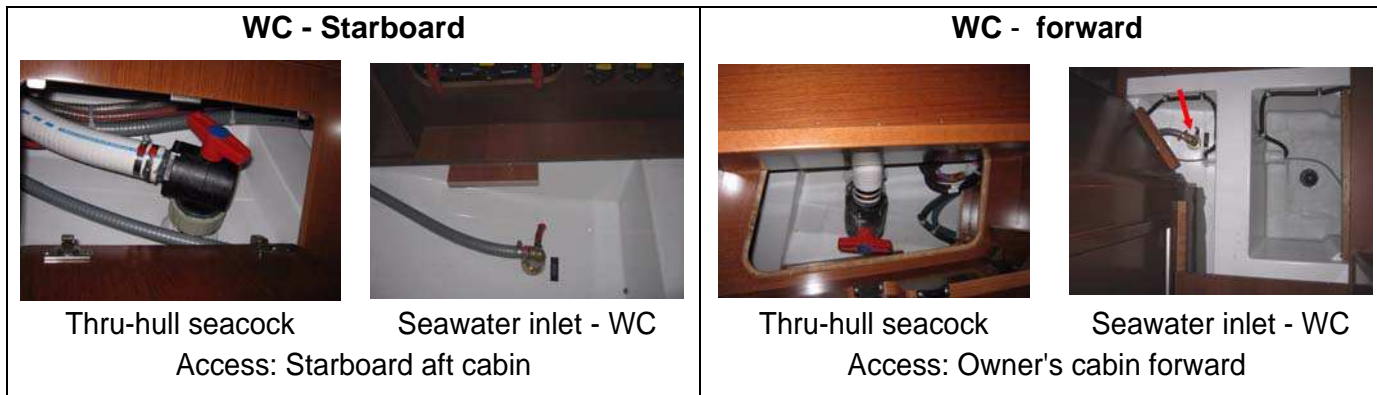

USE OF MARINE WCs FITTED WITH BLACK WATER TANK

Open the water intake valve (valve handle parallel to the pipe).

In the case of a direct discharge into the sea: Open the draining valve.

In case you store the waste waters in the tank: Make sure the draining valve is closed (valve handle perpendicular to the pipe).

To drain the bowl, set the control lever of the pump slantwise (FLUSH) then operate the pump.

To dry the bowl, set the lever vertical (DRY) then operate the pump.

In order to avoid clogging the heads:

- Only use absorbent paper in reasonable quantities.
- Schedule a regular rinsing through of the system with fresh water.
- Always retain a little water in the bottom of the bowl to avoid smells

To empty the tank:

- In an authorized area, open the draining valve.
- In a marina equipped with a system to suck the waste waters, put the sucking hose into the tank through the deck filler. Start the pump of the sucking system. The filler caps are opened and closed with an appropriate key. When the tank is empty, check the cap seal for condition then close the filler.



WARNING

-The tanks' nominal capacity cannot be fully used due to the load and the need to maintain the correct trim. A 20% reserve should be kept.



WARNING

-Ask for information about the laws in force in your country or your marina about discharging your waste waters into the sea.



PRECAUTION

-Close the valves after each use and above all when the boat is unattended.



PRECAUTION

-Regular check the tank level. High pressure due to too high a level may cause leaks or more unpleasant troubles.

Electrical equipment

- General information
- 12 V DC system
- 110-220 V AC system
- Equipment

12 V ELECTRICAL PANEL

Location: Chart table

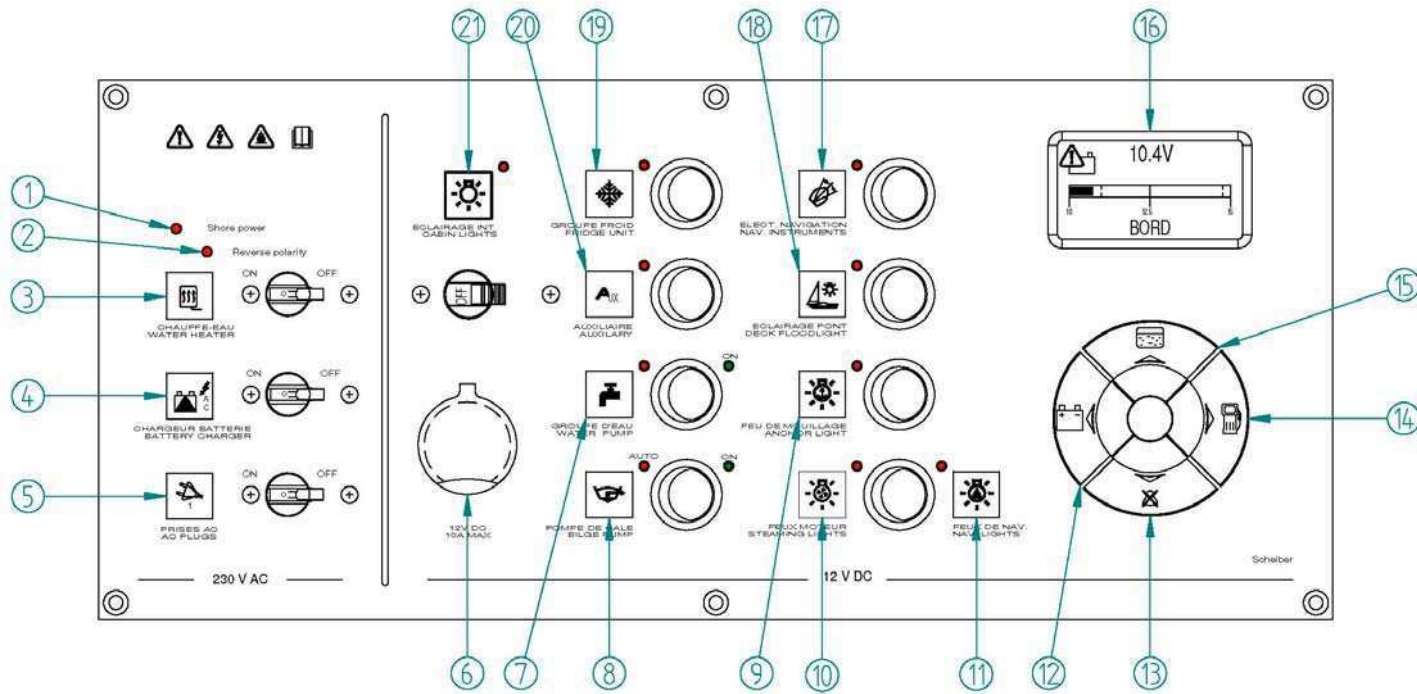

REF	Designation	REF	Designation
1	Indicator - common - Shore	12	Test batteries
2	Warning light - reversal of polarity	13	Alarm disabling
3	Control - Water heater - 220 V	14	Fuel gauge
4	Control - Battery charger - 220 V	15	Water gauge
5	Control - Sockets 220V	16	Multi-function display
6	Socket 12V	17	Electronic controls
7	Control - Water unit	18	Control - Deck light
8	Control - Bilge pump	19	Control - Refrigeration unit
9	Control - Mooring light	20	Control - Auxiliary
10	Control - Engine navigation light	21	Control - Interior lighting
11	Control - Navigation lights		

Electrical equipment 9

■ GENERAL INFORMATION.

ELECTRICAL PANEL

The electrical switchboard does not require any routine maintenance. In case an electric appliance is not energized, check:

- The main power supply (batteries, battery switches).
- The switches and circuit breakers on the line.
- the relevant electrical unit.

■ ELECTRICAL CIRCUIT, 12 V.

GENERAL RECOMMENDATIONS

- Never work on a live electric fitting.
- The batteries must be strongly fastened.
- Do not block the battery ventilation ducts, some of them may give off hydrogen which represents a danger of explosion.
- The batteries must be handled with care. In the case of contact with electrolyte thoroughly rinse off the affected part of the body and consult a doctor.
- To avoid short-circuiting between the battery poles do not store conducting objects near to the batteries (metal tools, etc...).
- Turn off the electrical circuit with the battery switches when installing batteries or during their connection/disconnection.
- Never modify the specifications of power overload protection devices.
- Never modify an installation. Use the services of a qualified marine electricity technician.
- Never install or replace the electric appliances (or any electric equipment) by components exceeding the capacity (amperage) of the circuit (Watt for bulbs).
- Do not leave the vessel unattended when the electrical system is switched on .
- Certain lights represent a significant heat source, be careful of surrounding objects.

Note that the 12 V circuit wires are red for positive and black for negative.



DANGER

-There may be danger of fire or explosion if direct current systems are incorrectly used.



WARNING

-Handle the batteries with care (Please refer to the manufacturer's instructions).
-In case of electrolyte splashing, thoroughly rinse the part of the body that has been in contact with it. Obtain medical advice.



ADVICE - RECOMMENDATION

-Keep the batteries clean and dry in order to avoid premature wear.
-Periodically check the electrolyte level. Add distilled water when needed.
-Tighten and maintain the terminal connectors by greasing them regularly.
-Disconnect the batteries during winter storage or long periods of inactivity.

Synoptic - 12 V

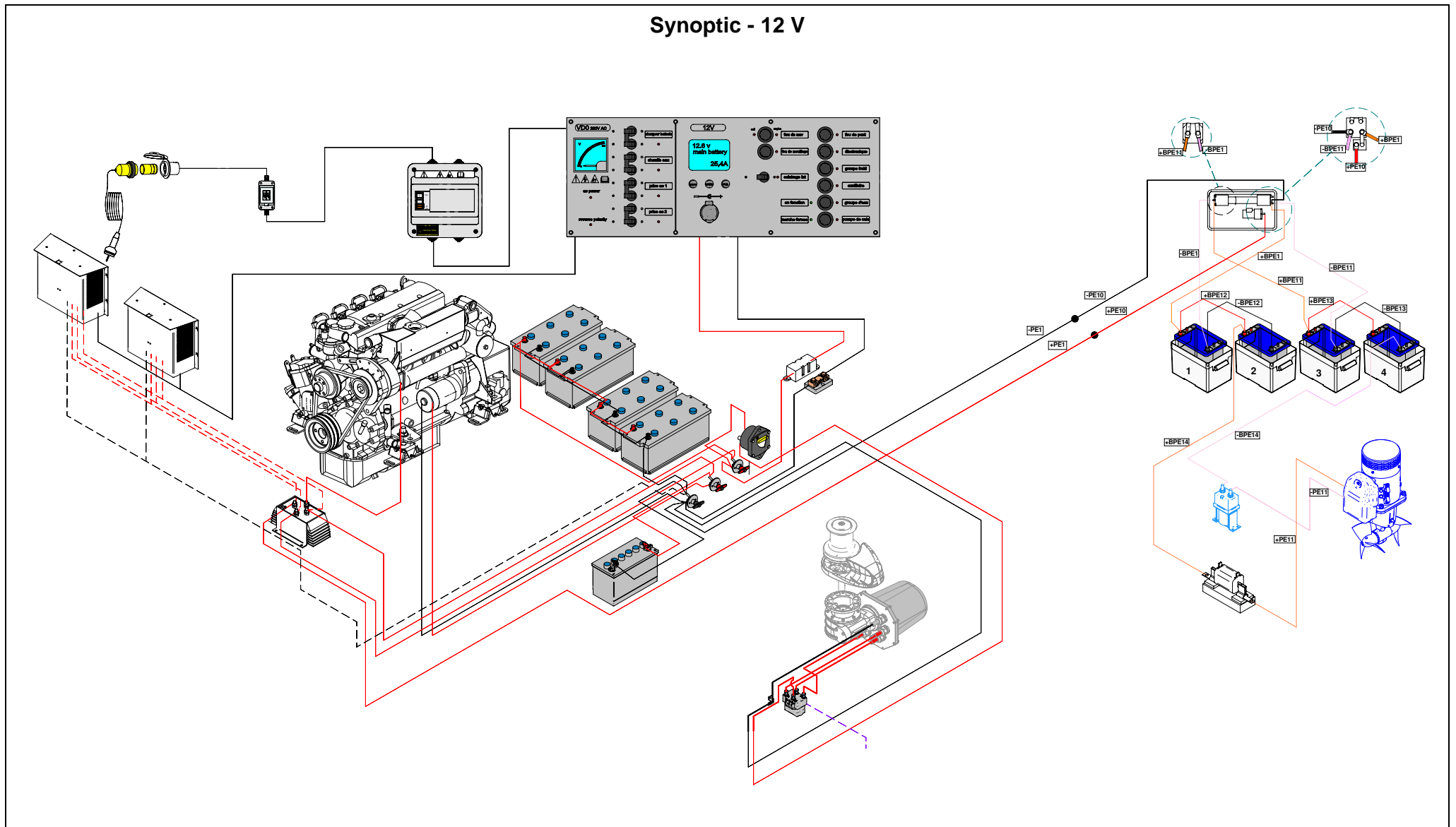

BOW THRUSTER 24V LOCATION

Elements - Forward cabin



1. Battery set (4 x 50A)
2. 200A fuse
3. Battery switch
4. Relay coupler
5. Motor 24V

Nozzle



OPERATION Control - Wheelhouse - Port side



Operation:

The thruster works with the vessel's engine running. The electric battery switch for the thruster automatically comes on or goes off when the thruster is started or stopped. The DC negative supply is connected to the main earthing point.

Electric winch

Location: Cockpit



Breaker

Location: Starboard aft cabin



Power:

80A: Winch circuit breaker - Labourer
135A: Winch circuit breaker - Genoa



WARNING

- Refer to the manufacturer's instructions for use and maintenance.
- Heavy use is made of the batteries when operating the electrical winches.
- Be sure to always recharge the 24 V battery set after a day's navigation under sail.

Electrical protection fuses

Circuit breakers



Circuit breakers are resettable.
Press the tab manually on black back on the road circuit.

Location - Chart table unit

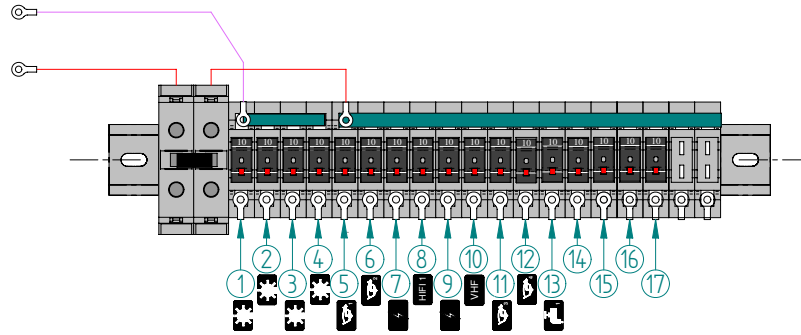

1. Lighting
2. Lighting
3. Lighting
4. Lighting
5. Shower pump
6. Shower pump
7. Solenoid - Gas
8. Hifi
9. VHF
10. Socket
11. Bilge pump
12. Waste water pump - Cool boxes
13. Deck light
- 14./15./16./17.. Options (See sticker)

Fuses

Location: Starboard aft cabin

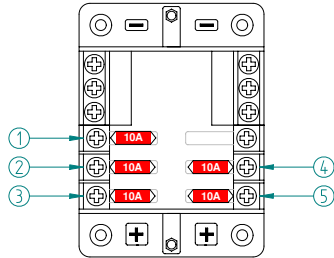

1. Fridge
2. Windlass
3. Thruster
4. Fridge
5. Engine compartment ventilator



FUSE - RELAY BOX - 12 V

Location: Starboard cabin

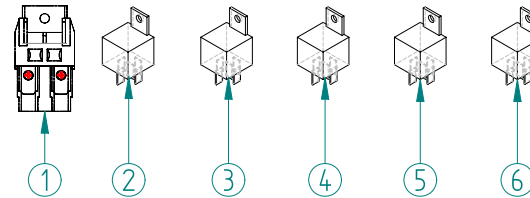

1. Fuse - Auto pilot
2. Bilge ventilator relay box
3. Windlass relay
4. Relay box - Thruster
5. Relay box - Fridge
6. Relay box - Fridge



WARNING

-Always replace a fuse with one of the same size.



Electrical equipment 9

BATTERY SWITCH

Location: Starboard aft cabin

1. Battery switch - Common negative
2. Battery switch - Positive engine
3. Battery switch - Service positive



BATTERIES

Engine battery
Capacity: 110A

Location: Starboard aft cabin



Service batteries
Capacity: 2 x 140A
Service batteries - additional
Capacity: 2 x 140A

Location: Under the companionway



Electrical equipment 9

BATTERIES

Battery charging is achieved through the alternator coupled to the engine or through use of the 220 V shore charger.

Keep the batteries charged enough (essential to ensure them a correct service life).

Make the most of time alongside to use the 220 V shore charger so as to start out sailing with fully charged batteries.

Always check the condition of the batteries and charge system before putting to sea.

BATTERY CHARGER

Operation

The battery charger operates based on a signal processor that converts alternating current (220V or 110V) into a direct current (12V). The operation of the charger is fully automatic, after selecting the type of battery and load type (Refer to the instructions for use).

Battery switch

The electricity onboard is 12 V DC.

The electrical system consists of service batteries.

The batteries supply power to all the functions on board.

The engine has its own battery.

Provide electricity to the system by turning on the positive and negative battery switches.

BATTERY CHARGER - 40A x 2

Location: Starboard aft cabin



Control

Location: Electrical panel



WARNING

- Never work on a live electric fitting.
- Do not touch the battery terminals, danger of electric shock.



PRECAUTION

- Switch off the electrical system with the battery switches when the boat is unattended.
- Never leave the vessel unattended with the mains electricity switched on.
- Turn off the electrical system with the battery switches and circuit breakers before gaining access to the rear of the electrical panels.
- Check the level of maintainable lead batteries.



ADVICE - RECOMMENDATION

- It is recommended that you switch off all electrical devices before turning off the battery switches.

ANODES

General points

- The sacrificial anodes protect the boat's metal components from electrolysis.
- A sacrificial anode is a consumable part that protects submerged metal parts by its dissolution (oxidation). The anodes used are made of a metal that is more readily reductive than the metal they are protecting.
- On a new boat, all the underwater metallic components try to be at the same electric potential, which leads to the rapid deterioration of the anodes in the first few weeks in the water.
- You can put several anodes on the hull.

Maintenance

- At least 2 times a year, check the corrosion on all of the anodes. Change the anode if necessary (Before it lost 50% of its weight).
- Use the appropriate anodes for the cruising area: fresh water/magnesium anodes; Sea water/zinc anodes.
- If the motor mountings are raised, the anodes are out of the water: in this case the anodes can no longer protect the sterndrive: take note of the skipper's recommendations.

When the boat is kept in a dry dock, a light deposit of dust will settle on the anodes: Before returning the boat into the water, clean the anodes.

Cleaning anodes

- Use sandpaper. Do not use metal brushes or steel tools to clean the boat, it may damage the galvanic protection.

Replacing the anodes

- The anodes are fastened with screws and nuts. First, remove the screws and nuts that hold the anode, then clean the contact surface. Press the new anode to obtain a good electrical contact.



WARNING

- Never cover the anodes in antifoul.
- During the first few weeks that the boat is in the water, check the anodes and if necessary replace them: they erode very rapidly during this period.

Electrical equipment 9

Cleaning anodes

- Use sandpaper. Do not use metal brushes or steel tools to clean the boat, it may damage the galvanic protection.

Replacing the anodes

- The anodes are fastened with screws and nuts. First, remove the screws and nuts that hold the anode, then clean the contact surface. Press the new anode to obtain a good electrical contact.

SHORE POWER SOCKET



**Differential switch 40A -
Chart table unit**



**Shore power socket 220V - 32A
(Ref 1)**



**Bipolar circuit breaker 32A
(Ref 2)**

■ ELECTRICAL CIRCUIT, 110-220 V.

GENERAL RECOMMENDATIONS

Certain vessels are equipped (as either standard or optional features depending on the model) with a 110 V or 230 V circuit.

The following measures are recommended in order to avoid the danger of electrical shock and fire:

- Never work on a live electric fitting.
- Plug in the boat/shore supply cable in the boat before you plug it into the shore supply socket.
- Never let the end of the boat/shore supply cable hang in the water.
- Turn off the shore supply with the onboard cut-off switch before connecting or disconnecting the vessel/shore supply line.
- Disconnect the ship/shore power cable at the shore socket first.
- Check the polarity indicator for the shore connections (110V AC version).
- If the reverse polarity indicator is activated immediately disconnect the cable. Rectify the polarity fault before using the vessel's electrical installation.
- Close the shore supply input cover firmly after use.
- Do not modify the vessel/shore supply line connections; only use compatible connections.
- Do not alter the vessel's electrical system. The installation, modifications and maintenance must be carried out by a qualified marine electricity technician. Check the system at least twice a year.
- Disconnect the vessel supply when the system is not being used. This is to prevent the danger of fire.
- Use double insulated or earthed appliances.

Note that the live wires are brown, the neutral ones are blue and the earth wires are green and yellow.



⚠ DANGER

- Never let the end of the boat/shore supply cable hang in the water: The result may be an electric field liable to hurt or kill the swimmers nearby.
- There may be danger of electrocution if alternating current systems are incorrectly used.
- Unplug the dock before leaving the dock.



⚠ PRECAUTION

- Never modify an electric fitting and relevant diagrams yourself.
- Call in a technician skilled in marine electricity to carry out any electric modification.
- Never change the breaking capacity (amperage) of the overcurrent safety devices.
- Never install or replace the electric appliances (or any electric equipment) by components exceeding the capacity (amperage) of the circuit (Watt for bulbs).



📌 ADVICE - RECOMMENDATION

- In order to reduce the risks of electric shock and fire:
- Before you plug in or unplug the boat/shore supply cable, switch off the shut off device connected to the shore supply.
- Plug in the boat/shore supply cable in the boat before you plug it into the shore supply socket.
- Unplug the boat/shore supply cable on shore first. Close the shore socket cover.
- Do not modify the connections of the boat/shore supply cable.

DIAGRAM - SCHEMA - 220V

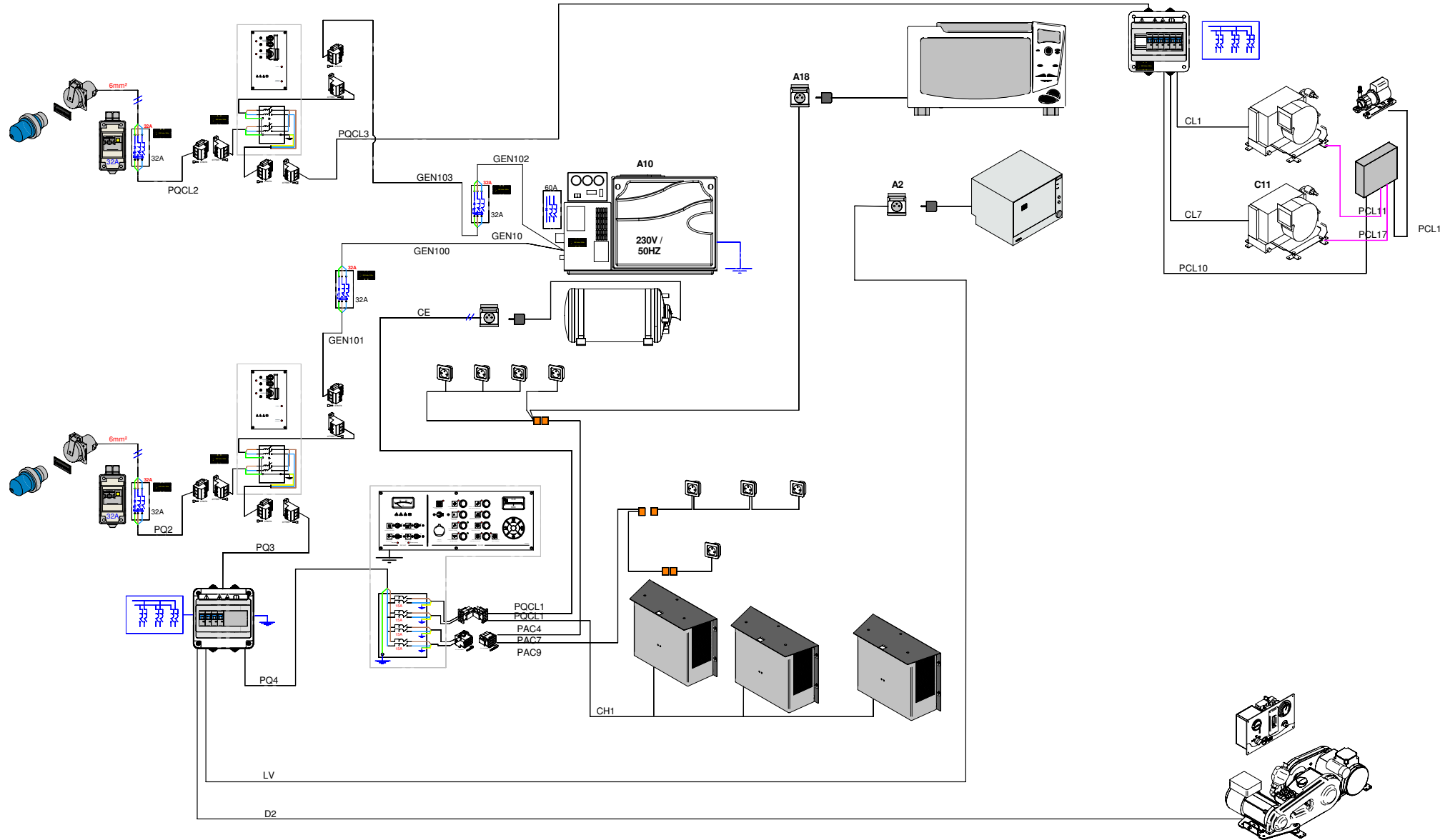

Electrical equipment 9

ELEMENTS 220V



TELEVISION

1. 30A breaker
2. Aerial
3. Inverter

Location: Chart table unit

OPERATION

The televisions power, supplied by a transformer which is powered with batteries of service, operates at 220V.

Starting up: First turn on the circuit breaker, then switch on the TV. The transformer is switched on and off automatically when you turn on or off the breaker.



WARNING

The inverter has an ON / OFF button.

AIR CONDITIONING

GENERAL POINTS:

The air-conditioning cools the air temperature inside the boat (only when the boat is floating in water).

The cooling circuit consists of one or more compressors that operate independently. A compressor is called "reversible" because it can heat the boat if the sea water temperature exceeds 10°C.

In winter, you can programme the dehumidifier function on the airconditioning controls.

The refrigeration compressors are made by one or two seawater pumps. These pumps are powered by 220V or 110V and are guided by one or two relay boxes.

Sea water is evacuated through a through-hull fitting equipped with a valve, located above the waterline.

Each compressor has its own through-hull evacuation fitting. It is advisable to check the flow of water visually once the air conditioning starts running.

OPERATION:

Before starting the engine:

- Open the raw water intake valves and evacuation valves.
- Use the switch on the chart table to select the power source (shore power or generator).

If using shore power: plug into the shore power socket ;

If using the generator: before turning on the air conditioning, leave the generator running for about 3 minutes.

The air conditioning is running:

- Switch the circuit breakers 220V ,from the air conditioning, ON.
- Select the temperature of each compressor using the control units.



WARNING

- Refer to the apparatus instructions for use and maintenance.
- Never start the generator when the climate function is already on.
- Always turn off the air conditioning before turning off the generator.
- Regularly check and clean the sea water filter placed on the sea water intake through-hull fitting.
- Clean the air filter (located in the compressor) regularly for maximum performance of the installation.
- Maintenance of filters (to engage in regular):
 - Close valves taken seawater.
 - Unscrew the top of the filter.
 - Clean the strainer.
 - Put everything back in place.

Electrical equipment 9

GENERATOR - SCHEMA

GENERAL POINTS:

A generator is a device that can produce electricity (220V or 110V) from a mechanical energy (fuel). The generator will feed the onboard equipment operating at 220V or 110V, moored or sailing.

OPERATION:

- Open the raw water intake valves and evacuation valves.
- Turn the generator's battery switch to the ON position.
- Switch the generator breaker (reference 5) ON.
- Turn the generator on by remote control (located on the nautical chart table) or your at your own generator.
- Check that any device is not running 220V or 110V. Then set the shore power/ generator switch (located on the chart table).

OPERATION:

- Supply - Diesel:

The generator is fed by fuel through the fuel tank port. The fuel filter (reference 1) is located at the generator circuit.

- Refrigeration:

The generator is cooled:

by seawater (inlet valve reference 8 sea water and sea water filter reference 2) ;

and by air (air exhaust duct, that runs through a ventilator and through the fresh air inlet).

- Electricity:

The generator includes its own battery to start the engine. The generator is earthed by an earthing plate which is located under the hull.

- Rejection:

The cooling water and exhaust gases are separated in the separator (reference 7) to avoid noise pollution.

The seawater is discharged below the waterline (Ref 9). The exhaust- pipe is located above the waterline (Ref 10).

Generator - Schematic diagram

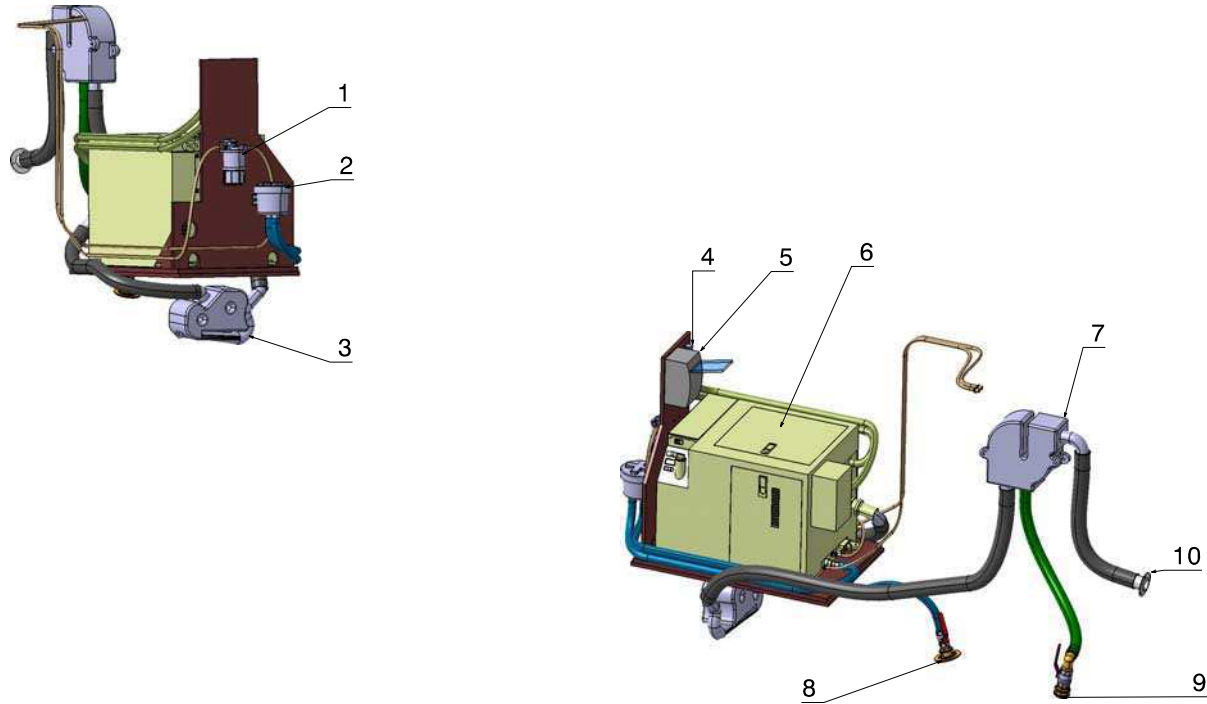

REF	Designation
1	Fuel filter
2	Sea water filter
3	Water trap
4	Anti-siphon valve
5	Differential circuit breaker
6	Generator
7	Water - Gas separator
8	Seawater inlet
9	Drainage - Sea water
10	Outlet

Electrical equipment 9

■ EQUIPMENT.

GENERAL INTRODUCTION

(As far as possible) use electric appliances with double insulation or with three conductors (Neutral-Live wire-Ground).

ELECTRONIC

Wire runs are available to complete the boat equipment.

Do not install electronic instruments or repeaters less than 1,50 m away from the radio loudspeakers.

Advice: For further information refer to the appliance instructions.

MAINTENANCE

Clean the repeater dials with freshwater. Refer to the instructions before using any other produce. The use of alcohol must be avoided.



ADVICE - RECOMMENDATION

- Place the protective covers on the repeaters when unused for long periods.
- When sailing store the protective covers inside the boat to avoid losing them.
- The various repeater displays are back-lit.
- The onboard radio is fitted with two outside speakers.
- When mooring be careful to adjust the sound so as not to disturb your neighbours !

ELECTRONIC - TRANSDUCER LOCATION



View - interior



View - Outside

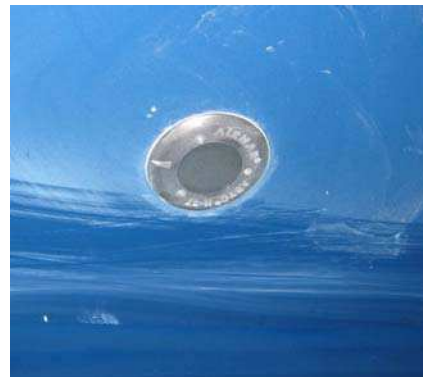

ELECTRONIC

LEAD LINES

The log and depth sounder sensors are located under the forward cabin floor. Keep the log sensor cowl close to the instrument so as to be able to intervene in complete safety.

Do not store material on top of the sensors.

AUTO PILOT

The pilot consists of several elements listed as follows:

- Repeater in the cockpit starboard side above the engine panel.
- Calculator, piston, hydraulic pump and rudder either side of the steering stock in the aft locker (access through one of the two cockpit lockers under the tiller seating).
- To supply power to all elements switch on the "Navigation" circuit breaker on the electrical panel.
- For use and maintenance of the material consult the manufacturer instructions.

PILOT ELEMENTS

Piston

Access: Port aft cabin



MAINTENANCE

Clean the transducer probe during each dry dock and the log sensor regularly. Read the instructions for maintenance recommendations.

Refer to chapter 11 "Launching" for the precautions to be taken concerning the sensors during hoisting.



ADVICE - RECOMMENDATION

- For best results, remove any metal compass.
- Do not store material close to the calculator and electrical connections.

ELECTRONIC - SCHEMATIC DIAGRAM

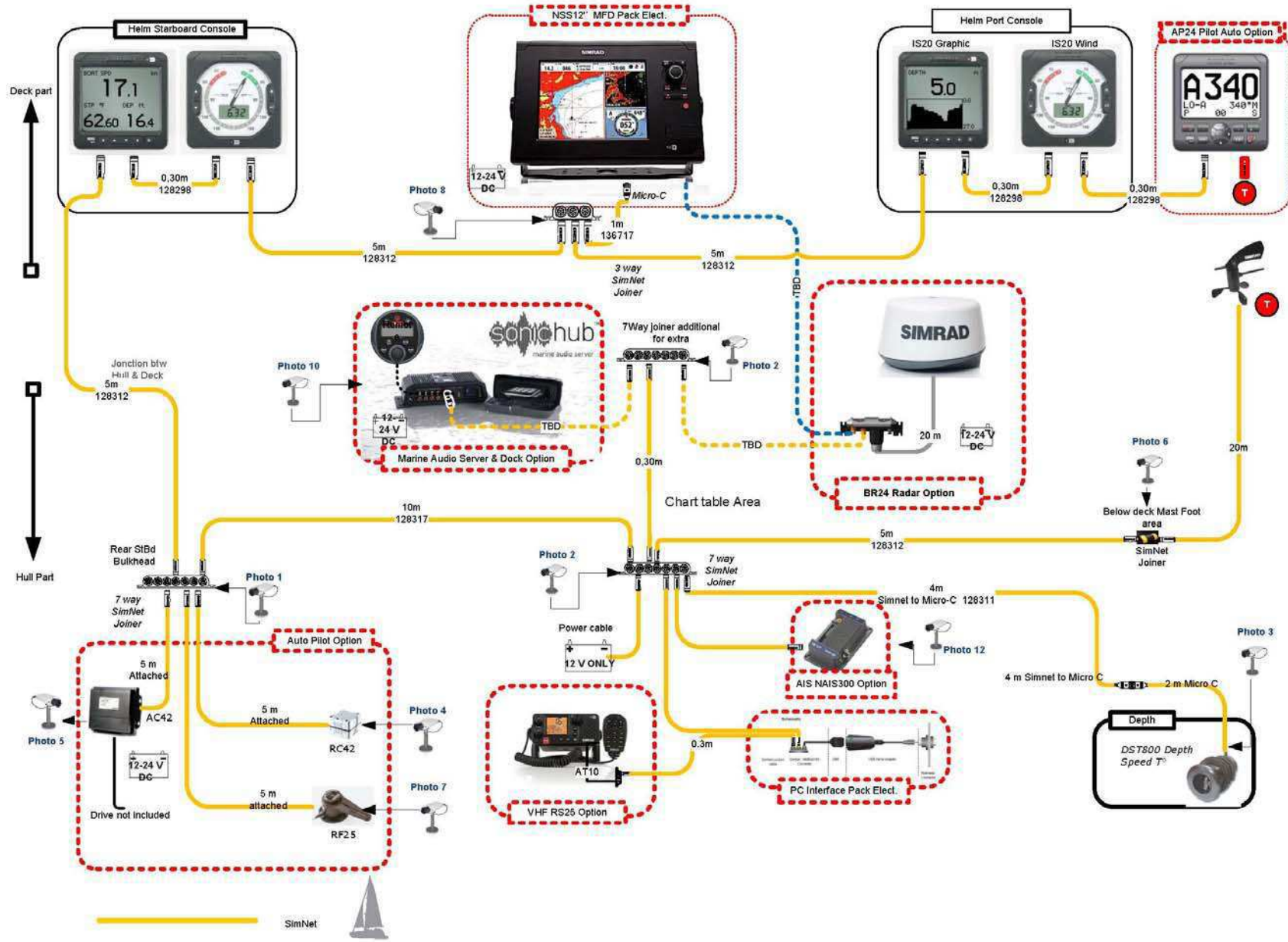

Electrical equipment 9

LAYOUT OF COMPONENTS

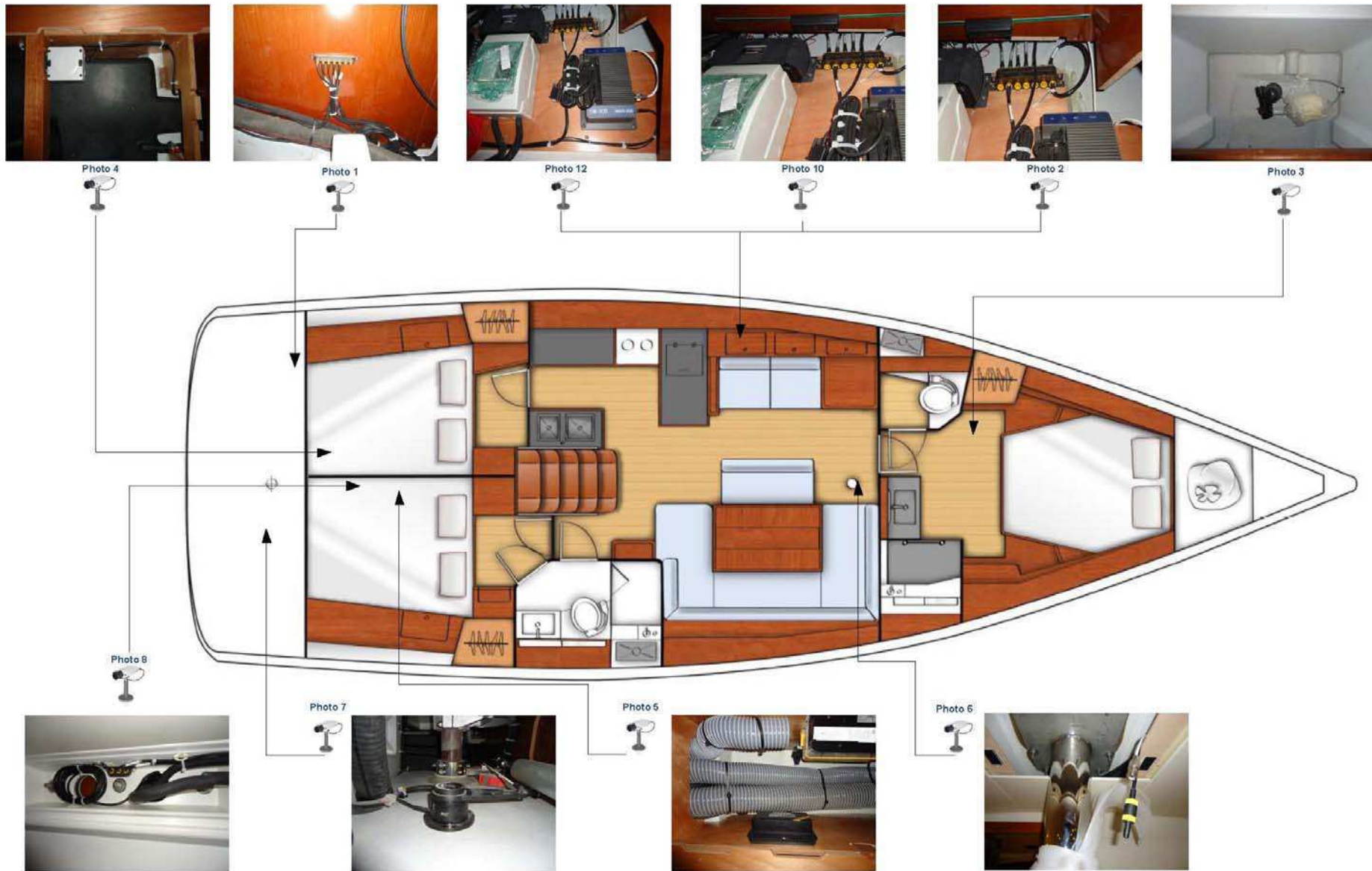

Engine

- General information
- Engine fitting
- Dock and go version

Fuel tank
Location: Port aft cabin
Capacity: 200 litre



Deck filler



**Gauge -
Electrical panel**



Extra tank
Capacity: 200 litre
Starboard aft cabin



Selection pull tank
Lever pushed: Supply - Starboard tank
Lever pulled: Supply - Port tank
Location: Starboard aft cabin



Correspondence:
Tank 1: Port side
Tank 2: Starboard
Refer to the instructions for use.

■ GENERAL INFORMATION.

TYPE OF MOTORISATION

Your vessel is fitted with an in-board diesel engine.

Transmission type is Sail Drive (Sail Drive version).

The transmission is POD type (Dock & Go version).

PRECAUTIONS OF USE, OPERATING ADVICE

General point

- In this vessel, do not install an engine with a greater power and weight than that recommended, this will create a danger for its stability.
- Fuel which is stored elsewhere than in the fuel-tanks (portable tanks, jerrycans, etc...) must be kept in a ventilated space.
- Make sure that the engine compartment is clean and dry.
- Avoid contact between inflammable substances and the hot parts of the engine.
- Locate the extinguisher hole which allows access to the engine compartment if a fire should break out. (Refer to chapter 2).

Filling

Fill the fuel tank using the filler. In order to protect the deck from possible fuel splash, wet the area around the filler with sea water before you remove the filler cap. In case of splashing rinse the deck thoroughly (deck filler closed).

The fuel level is transmitted from the dipstick to the guage located on the house electrical panel.



DANGER

- Stop the engine and refrain from smoking during fuel tank filling.
- Make sure that the ventilation openings in the engine (and generator, if installed) compartment are well cleared.



PRECAUTION

- Never run the engine when the boat is hauled out.



PRECAUTION

- Stop the engine before you open the companionway hatch and side hatches.
- In case of an intervention when the engine is running:
- Stay away from belts and hot or mobile parts.
- Be careful with full clothes, long hair, rings etc. (you may be caught).
- Wear appropriate clothes (gloves, caps etc.).



ADVICE - RECOMMENDATION

- Carefully read the engine instructions given with your boat.

MOTOR - DIAGRAM - LOCATION

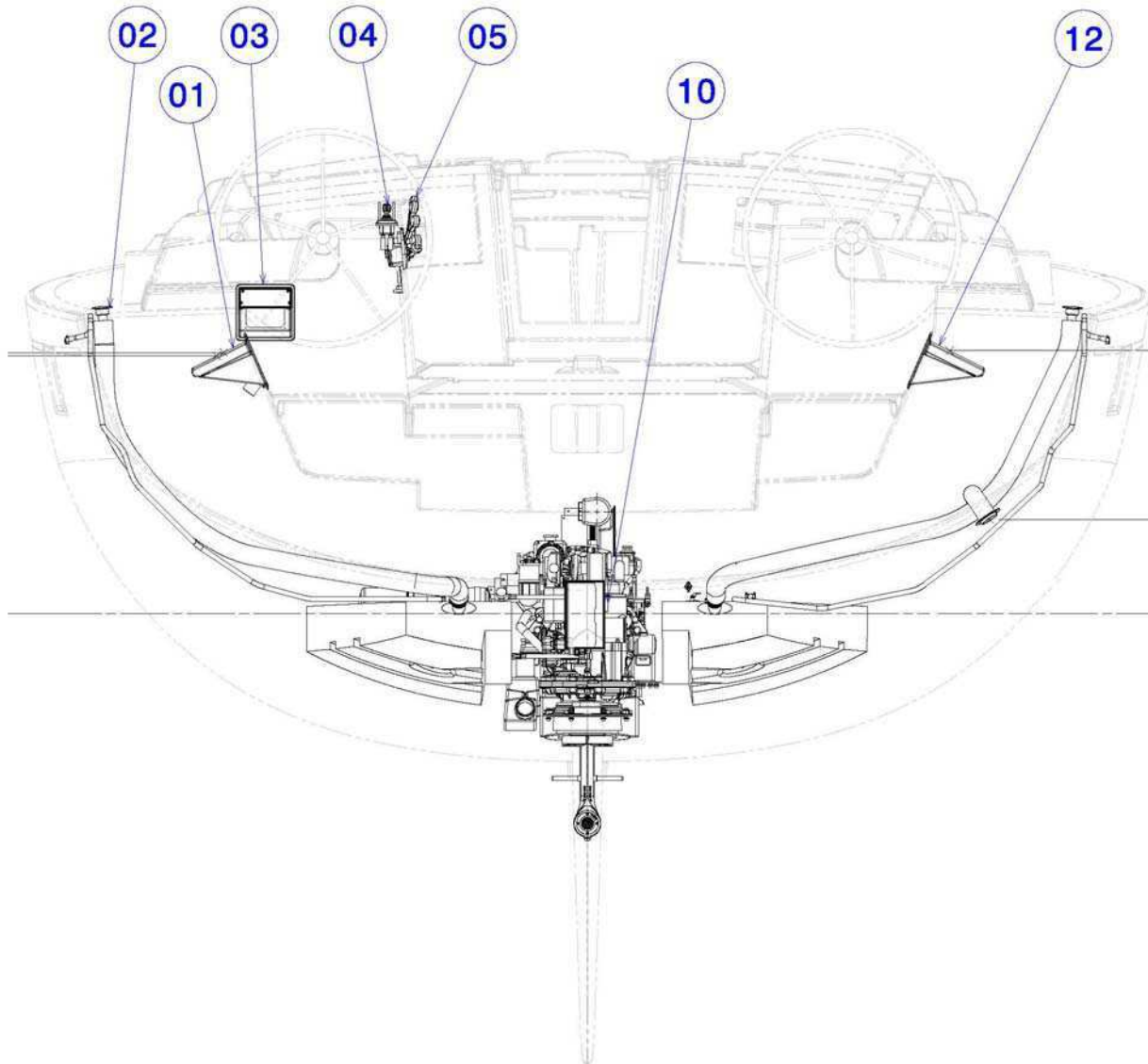

Engine 10

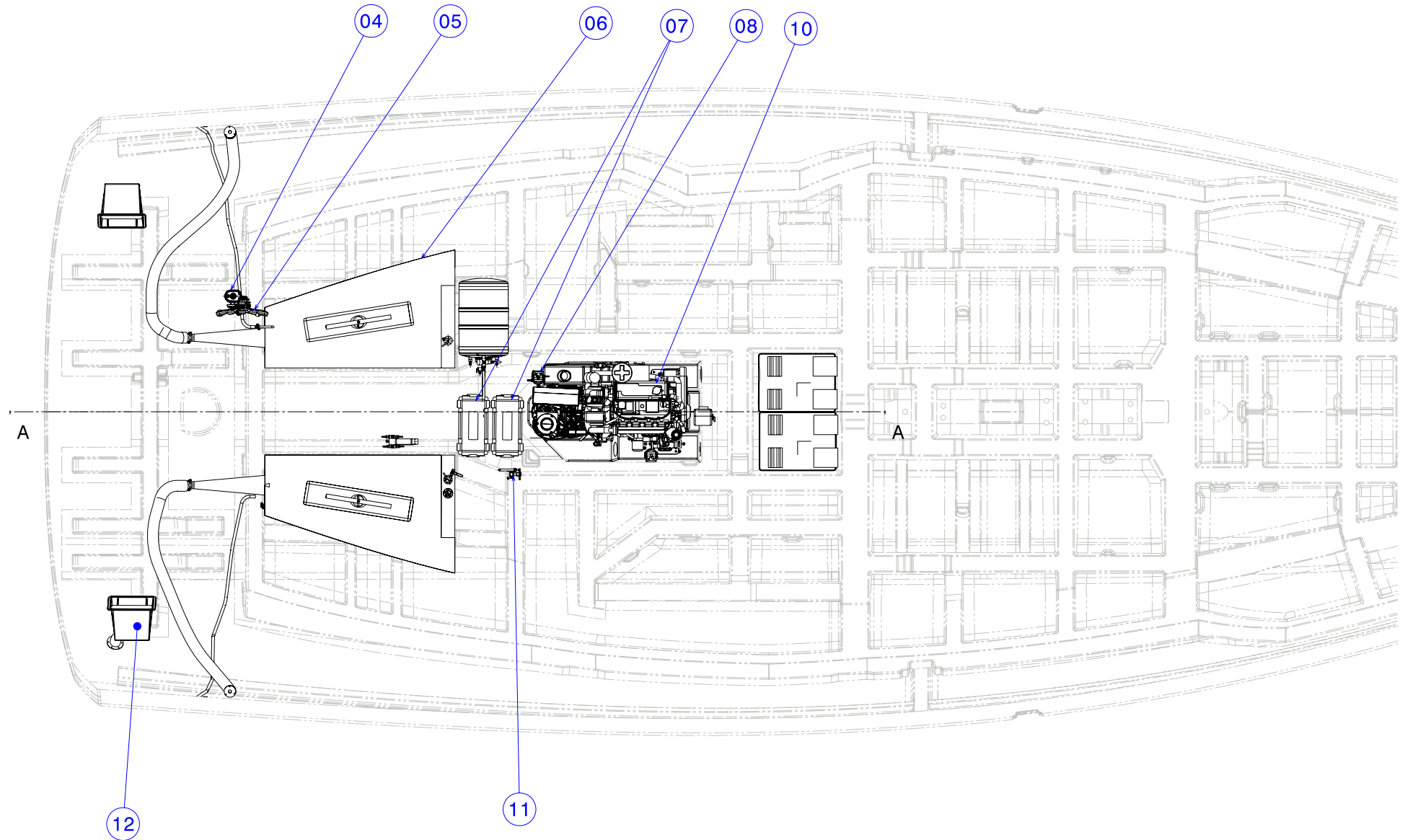

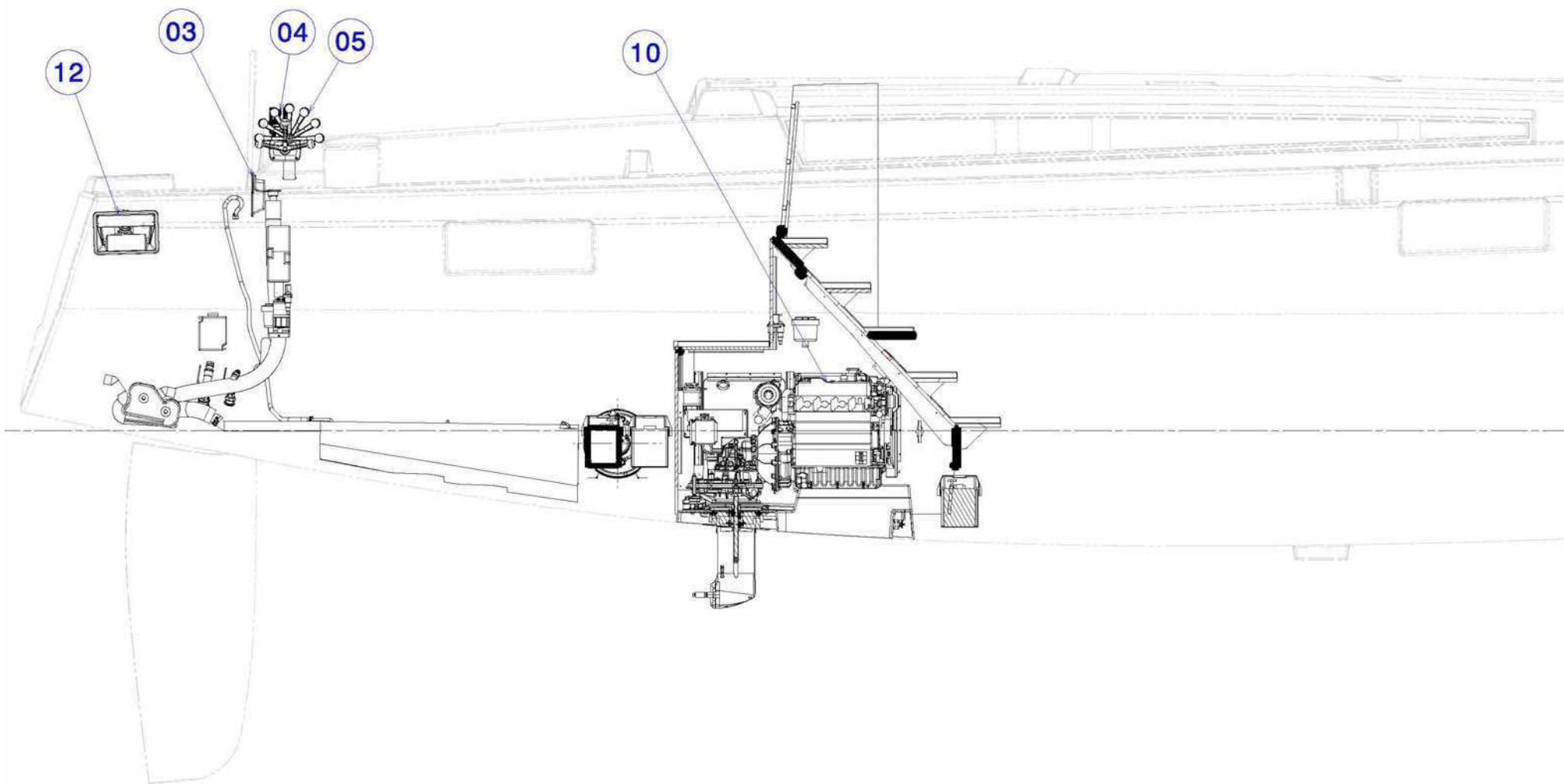

Engine 10

REF	Designation
1	Inlet - fresh air
2	Deck filler
3	Instrument panel - Motor
4	Joystick
5	Engine control
6	Tank
7	Service batteries
8	Filter
9	Engine battery
10	Motor
11	Battery switch
12	Hot air extraction

MAIN COMPONENTS OF THE ENGINE

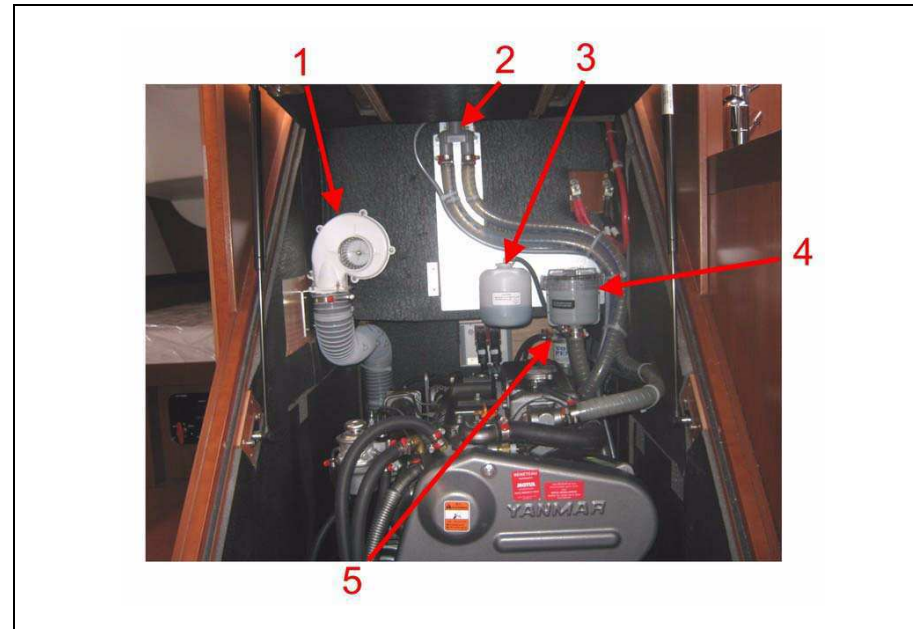

REF	Designation
1	Ventilator
2	Anti-siphon valve
3	Expansion tank
4	Sea water filter
5	Diesel filter

Engine 10

Motor

These instructions give detailed explanations on proper operation of the engine.

- Refill before the fuel tanks have almost run dry (the fuel system may be stopped for lack of fuel).
- Make sure you have enough fuel before sailing.

Access to the engine

You have access to the engine via the companionway hatch.

You can check the main parts thanks to side hatches.

Engine water intake valve

The water inlet valve of the engine is essential in the engine operation.

- Keep the strainer under the hull as clean as possible.
- Brush the strainer whenever the boat is lifted out.
- Do not cover the strainer with antifouling paint.

It is essential that this valve is open before the engine is started (danger of rapid wear and substantial damage to engine installation).

If water does not flow out:

- Stop the engine immediately.
- Check that the valve is open.

Close the water inlet valve if the boat is unattended for long.

Inspect and clean the water filter regularly.

Engine operation

Before starting the engine:

- Turn on the fuel valve.
- Open the engine cooling system valve.
- Operate the battery switches and energise the electric system.
- Disengage the reverse gear (it will make the acceleration possible when in neutral).



DANGER

- Always start the engine with the control lever in neutral.



WARNING

- Never switch off or de-energise the electric system when the engine is running.
- Imperatively operate the stop pull handle (or button) before using the ignition key to switch off a diesel engine.



WARNING

- The tanks' nominal capacity cannot be fully used due to the load and the need to maintain the correct trim. A 20% reserve should be kept.



ADVICE - RECOMMENDATION

- Get used to checking immediately after starting the engine if water is expelled with the exhaust gases.

SUPPLY VALVE FUEL + SEA WATER INLET VALVE FOR ENGINE



**Supply valve
Tank
(Ref 1)**



**Engine water intake valve
(Ref 2)**

View interior



Stuffing box



**Supply valve
Extra tank
(Ref 1)**



Engine 10

Fuel filter

Engine running problems may have different origins, including dirty fuel. The injection pump may wear out if there is water in the system.

The water results either from the condensation resulting from an insufficiently filled tank, or from a filler cap either not closed properly or with a damaged seal.

In order to prevent any water infiltration, the fuel runs through two filters:

- One filter is an integral part of the engine, its role is to filter fuel very finely. To know when you have to intervene and how frequently you have to change it, please refer to the engine's manual.
- The second filter is on the pipe that links the tank to the engine, it plays the role of a water decanter and prefilter.

Drain by undoing the knurled screw at the base of the decantation bowl (but not removing it).

Allow to flow into a box till the fuel looks clean.

Do this several times a year.

Change the pre-filter at least once a year (access to it when you remove the bowl).

As for the procedures in case of fire, refer to Chapter 2.



DANGER

-Never obstruct access to the fuel valve.

Engine control



REF	Designation
1	Control - Reverser
2	Joystick Dock and Go

Engine panel detail



REF	Designation
1	Tachometer Revolution counter
2	Control indicator lights
3	Pre-heating
4	Stop/start switch

Propeller detail

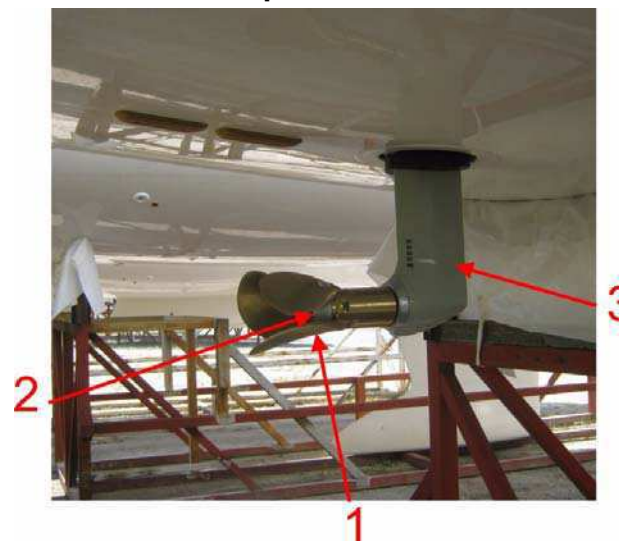

REF	Designation
1	Propeller
2	Anode
3	Base

Engine 10

The instrument panel has all the testing functions of the engine and it does not require any special precaution (refer to engine leaflet).

Check the clutch and accelerator cables (lubricate the end fittings and forks).

VISIBILITY FROM THE STEERING STATION

The international regulations to prevent collision at sea (COLREG) and the course regulations make mandatory a permanent and proper surveillance and the respect of priority.

Make sure there is no other boat on your way.

The visibility from the steering station may be obstructed in the following conditions:

- Speed.
- Position of the upper and side awnings.
- Boat heeling over, the sails reduce visibility under wind.
- Load and load distribution.
- Sea conditions, rain, spray, fog or darkness.
- Lights on inside the boat.
- Persons and removable equipment in the helmsman's field of visibility.



PRECAUTION

- Do not change the propeller without specialist's advice.
- Regularly check the anode for corrosion, at least 2 times a year.



ADVICE - RECOMMENDATION

- When the engine is running, avoid making noise and chops near the other users.
- Respect speed limits.
- If this boat is equipped with a fixed blade propeller, when sailing at speeds over 8 knots it is essential to leave the reverse gear control in neutral.
- To start the engine again, reduce the speed of the boat when sailing (in order to be able to disengage the clutch before starting it again).

■ DOCK & GO VERSION

General point



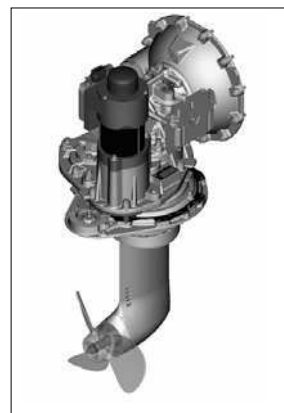

- The Dock & Go transmission is an electronically controlled mechanical transmission.
- This type of transmission operates without a reverse gear, reversing is achieved by rotating the POD 180 degrees.
- The Dock and Go system is powered by the service batteries circuit onboard: the battery bank must be sufficiently charged to enable the system to run well. An insufficiently charged battery bank (at the start of a new season, for example) risks damaging the onboard electrical system.
- The forward and reverse travel of the boat are controlled by the engine control lever. In passing from forward into reverse POD rotates 180°.
- The POD's orientation in all directions is carried out by the joystick.
- The joystick controls the propeller and the bow-thruster. By moving the joystick on the X and Y axes, the boat moves on these axes.
- Rotating the joystick makes the boat rotate around its centre.











ADVICE - RECOMMENDATION

- It is imperative to change the transmission oil after the 250 first hours of use (please consult your dealer).

Start Quick Guide

Start the engine using the control lever (forward and reverse)		
1	Turn on all battery switches.	
2	Start the engine.	
3	(if necessary) Activate the bow thruster manually: Steady green light on the control panel.	
4	The lever is operational.	

Start the engine, using the joystick to move sideways (Dock & Go)		
1	Turn on all battery switches.	
2	Turn on power to the navigation electronics at the electrical panel.	
3	If necessary according to auto pilot model, put into STAND-BY mode at the exterior helm station.	
4	Start the engine.	
5	Activate the bow thruster manually: Steady green light on the control panel.	
6	Activate the joystick of the Dock & Go by pressing the joystick button (Hold the button down for a long time and the 2 indicator lights will changed to steady green).	
7	The joystick is operational.	

Deactivate the joystick to take control of the engine with the lever		
1	Hold the joystick button down for a long time (1 red indicator light).	
2	The engine control lever is operational.	

Diagrammatic view

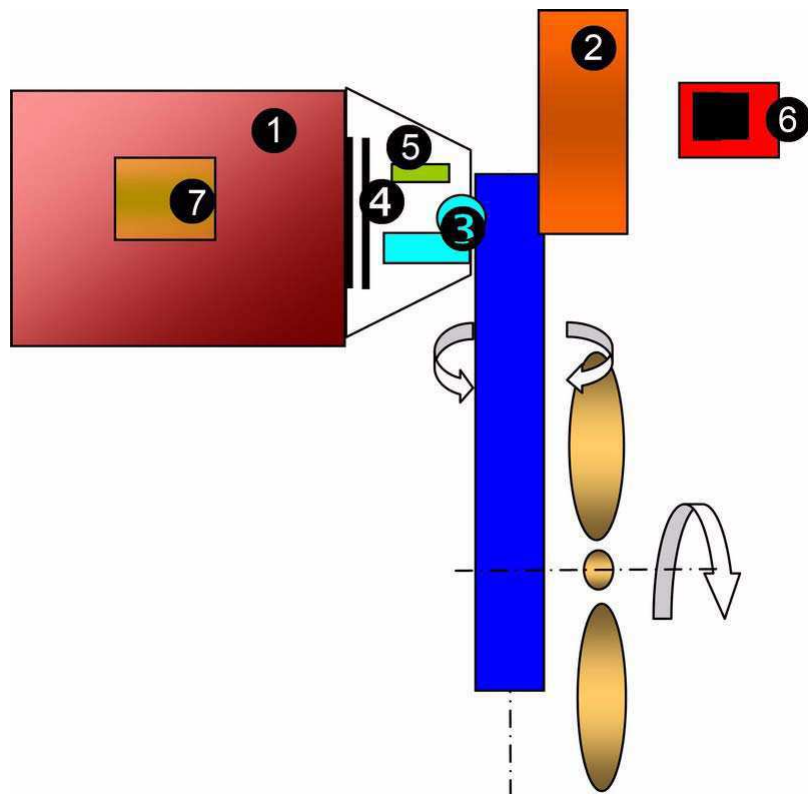

Reference	Designation
1	Heat engine
2	POD rotary motor: Make the POD under the waterline turn 270 to starboard
3	Clutch actuator: enables gear engagement and disengagement
4	Clutch: Mechanical linkage between the engine and the propeller shaft
5	TCU: (Transmission and Clutch Management) interface between the clutch activator and the VMU
6	VMU (Vessel Management Unit): the brains of the system, it gathers all the info from the system(joystick, control lever, TCU, POD..) and tells it what to do
7	Throttle actuator: electric accelerator interface between the electric control and the fuel pump

Engine 10

LAYOUT OF COMPONENTS

Rotating motor
(Ref 2)



Clutch actuator
(Ref 3)

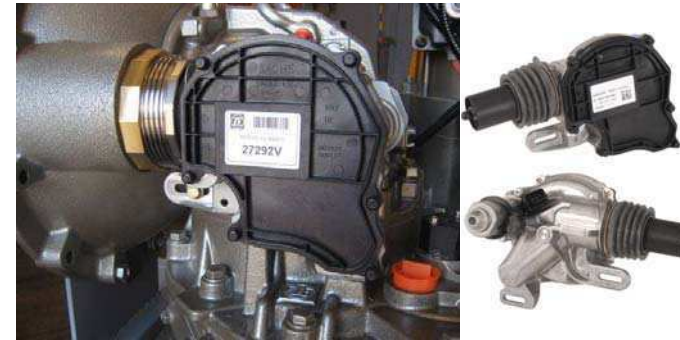

TCU housing (Transmission and Clutch Management)
(Ref 5)

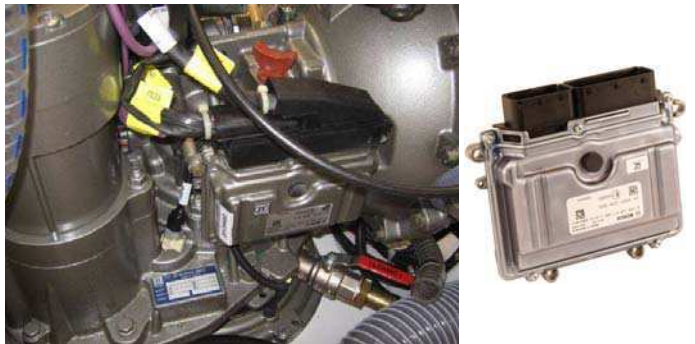

VMU housing (Vessel Management Unit)
(Ref 6)



Throttle actuator
(Ref 7)



LAYOUT

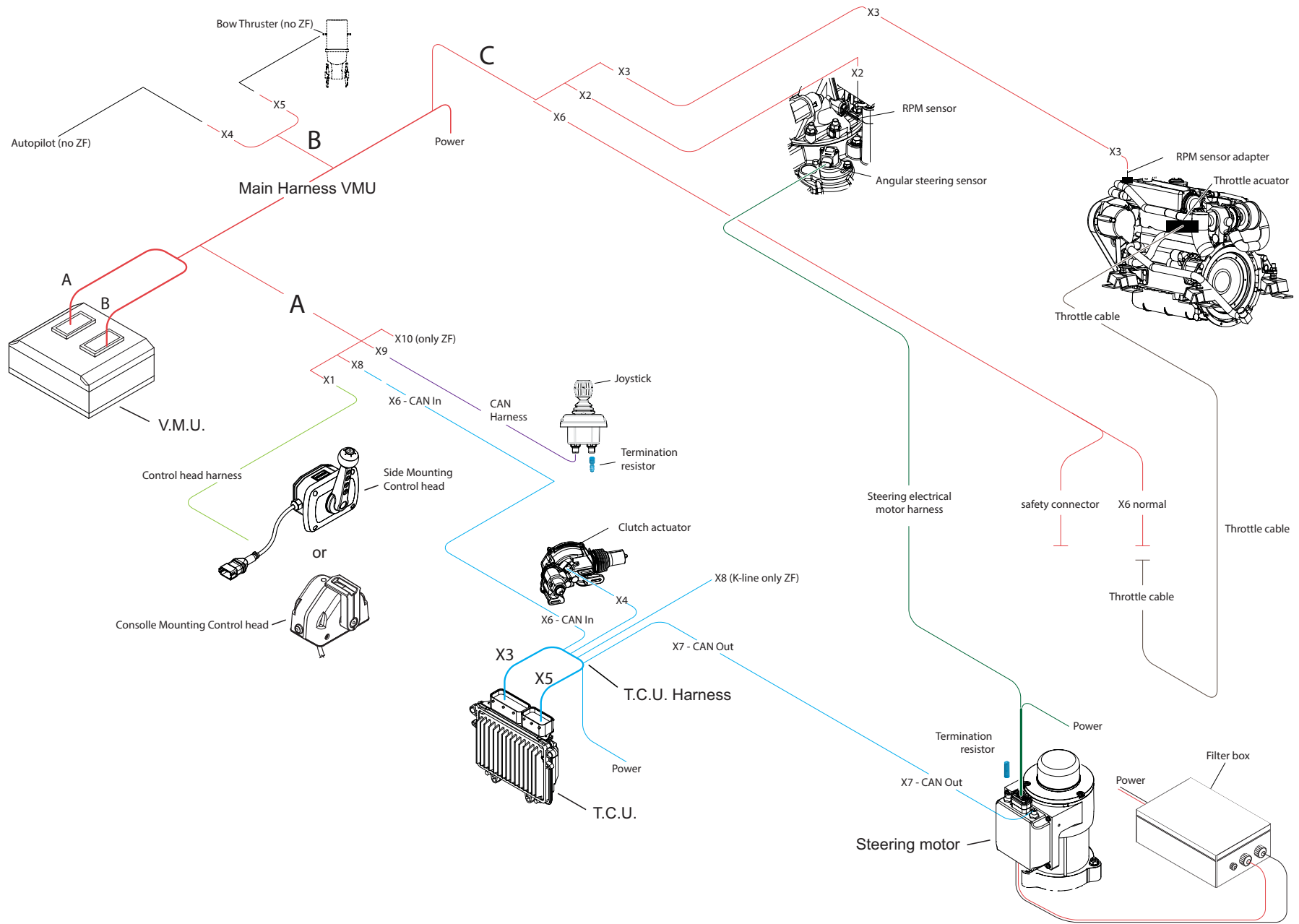

Operation

1. General points

- The Dock and Go system is a manoeuvring aid to facilitate coming alongside and leaving the dock. This system must not in any circumstances be used as a means of navigation, even during approach manoeuvres in port.
- In some use modes of the system, especially sideways movement, the bow thruster has to work very hard. This leads to a significant power draw on the bow thruster battery bank and raises the temperature of the bow thruster motor.
- For its protection, the bow thruster is equipped with a temperature alarm which gives 5 short beeps 10 seconds before cutting off the power to the bow thruster. When the bow thruster cuts out, keep your hand on the joystick with the bow thruster out of operation. You need to wait until it has cooled sufficiently before restarting it manually by pressing both buttons on the bow thruster control simultaneously.
- To avoid this inconvenience and to protect the bow thruster we advise you not to use the bow thruster for more than 30 seconds at a time and to allow it to cool between each use.
- NOTE: Once the bow thruster has cut out due to overheating you should allow around 4 hours for it to return to ambient temperature. If it does overheat you can start using it again without waiting 4 hours but the possible usage time will be reduced.
- After each manoeuvre using the bow thruster, be sure to maintain the charge of the bow thruster battery bank: either by connecting your boat to the mains socket on the dock, or by keeping the engine at a cruising speed of at least 1700 rpm (engaged or disengaged) for at least 30 minutes after the last manoeuvre.

2. Propeller



WARNING

- The propeller supplied with the boat is the only propeller validated by the engine manufacturer that allows optimal operation of the Dock and Go assembly. No other propeller should be fitted otherwise there will be serious malfunction of the base or of the engine itself.

3. Operation

- Turn on all battery switches. The bow thruster battery master switches will turn on automatically when the bow thruster control is picked up.
- Open the fuel supply valve(s) from the fuel tank(s).
- Open the engine water inlet valve.
- Switch on the navigation electronics (Electrical panel).
- According to the auto pilot model and screen model, it may be necessary to touch the POWER button on the screen at the helm station to activate the auto pilot in "MOTORISED HELM" mode or POWER
- Check that the engine control lever is in neutral.
- Switch on the engine.
- Start the engine.
- Activate the bow thruster manually using the control push button. A steady light illuminates on the bow thruster control panel: The system is operating.
- Press the joystick button and hold down for 2 seconds before activating the joystick. When the button is released, the 2 LEDs on the joystick will change to steady green.

Engine 10

4. Joystick operation

REMINDER: Before using the system, ensure that the bow thruster light is illuminated (see above) once the boat's engine is started. Check that the bow thruster indicator light is showing steady green when the joystick is in operation.



The joystick is on STAND-BY: This means that it is ready for use.

The «Ready» LED is a steady red. The engine is controlled by the engine control lever.

Place a hand on the joystick and press the button for 1 second. The green LEDs illuminate when the button is released.



The 2 LEDs are illuminated as steady green lights (not flashing).

The joystick is operational, the control lever is out of action.

The wheel turns to lock the helm and rudder along the longitudinal axis of the boat.

Be careful to keep arms clear of wheel as it turns.

The pilot display shows =

"MOTORISED HELM" version RAYMARINE.

POWER version SIMRAD.

The indicator light on the bow thruster control panel is showing steady green.



Whenever an instruction is given to the joystick (here in forward) the LED «control» illuminates red.



DANGER

- If you activate the joystick while the rudder blade is not in the same position as the boat's axis, it will automatically move itself to the correct position.



WARNING

- The wheel will spin quickly and may catch your arm, clothes, hands as it does so: keep away from the wheel when the system is running.



ADVICE - RECOMMENDATION

- The joystick button must be released to operate the joystick.

USING THE JOYSTICK

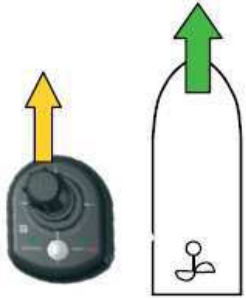

Push the joystick forwards.

The boat moves forwards. The acceleration is proportional to the position of the joystick.

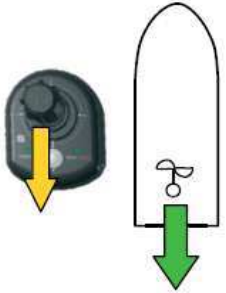

Push the joystick back.

The boat moves backwards. The acceleration is proportional to the position of the joystick.

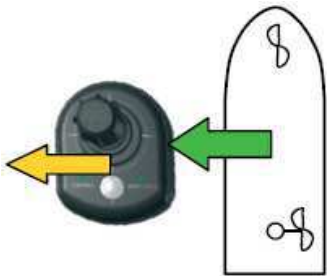

Push the joystick to port.

The boat moves to port. Acceleration can be altered by turning the joystick (clockwise: boat accelerates, anti-clockwise: boat decelerates) and the bow thruster operates.

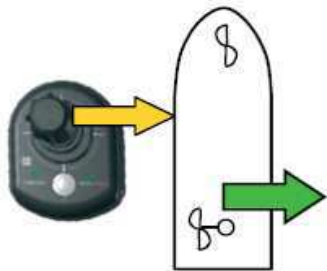

Push the joystick to starboard.

The boat moves to starboard. Acceleration can be altered by turning the joystick (clockwise: boat accelerates, anti-clockwise: boat decelerates) and the bow thruster operates.

Engine 10



Several movements can be combined:

Push the joystick to starboard + Turn the joystick clockwise.
The boat moves to starboard but the bow swings more quickly than the stern.

Push the joystick to starboard + Turn the joystick anti-clockwise.
The boat moves to starboard but the stern swings more quickly than the bow.

You can do the same to port:

Push the joystick to port + Turn the joystick anti-clockwise.
The boat moves to port but the bow swings more quickly than the stern.

Push the joystick to port + Turn the joystick clockwise.
The boat moves to port but the stern swings more quickly than the bow.



WARNING

- The effects of the Dock & Go system's rotation will be noticeable to a greater or lesser extent depending on the boat's way.

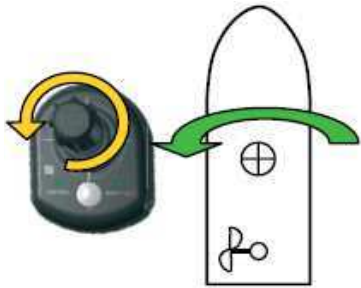

Turn the joystick anti-clockwise.

The boat turns to port (virtually pivoting around its keel). Forward or reverse acceleration is proportional to the position of the joystick.

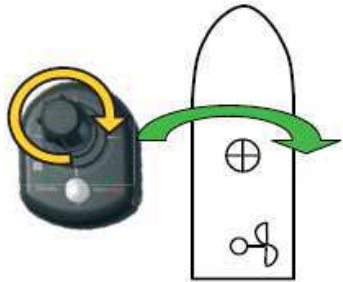

Turn the joystick clockwise.

The boat turns to starboard (virtually pivoting around its keel). Forward or reverse acceleration is proportional to the position of the joystick.



Push the joystick forwards + turn clockwise.

The boat moves forward and turns to starboard.

The acceleration is proportional to the position of the joystick.

Do the same manoeuvre turning anti-clockwise.

The boat moves forwards and turns to port.

The acceleration is proportional to the position of the joystick.



Push the joystick back + turn clockwise

The boat moves backwards and turns to port.

The acceleration is proportional to the position of the joystick.

Do the same manoeuvre turning anti-clockwise.

The boat moves backwards and turns to starboard.

The acceleration is proportional to the position of the joystick.

Engine 10

QUIT JOYSTICK MODE



Press the button for 1 second.

RAYMARINE version: The auto pilot comes out of "MOTORISED HELM" mode and goes into STAND-BY mode.

SIMRAD version: The auto pilot comes out of POWER mode and goes into STAND-BY mode.



The joystick goes into STAND-BY.

The «Ready» LED is a steady red.

The system switches automatically to control lever function.

If the lever is not in the neutral position it must be put into neutral before using.

Explanatory note regarding the joystick in flashing red «Ready» LED mode:

When the red «Ready» LED is flashing, this indicates that a malfunction has been detected in the system. This malfunction may occur when the engine is started or the joystick is used.

In some cases, this fault may be resolved by completely restarting the system (Recommence starting procedure set out above).

If after restarting the joystick is still not working, use the engine control lever and bow thruster manually.

If control lever is not working, apply emergency procedure SAFETY set out in owner's manual ZF.



WARNING

-To retake control with the engine control lever, it is essential to disengage the joystick by pressing the button behind the joystick.

5. MODE WARM UP (warming up the engine)

- WARM UP mode is a mode in which the engine is disengaged and accelerated.
- To engage the "WARM UP" position, press the button and keep it pressed whilst moving the throttle to the first forward notch, then release the button. "WARM UP" is only possible in forward gear.
- To come out of WARM UP mode, return the lever to neutral.

6. Procedure for shutting down the engine:

Put the control lever in neutral AFTER ENGAGING FORWARD GEAR FOR A FEW SECONDS, so the POD is properly located in the ahead position.

Wait 10 seconds before switching off the engine.

7. Maintenance

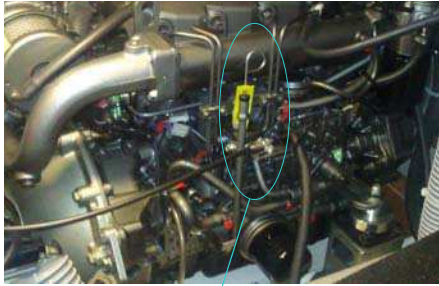

Check engine oil level.

The level must be between the 2 marks on the gauge (see engine manual).

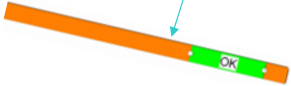

Check POD base oil level.

The level must be taken by inserting the dipstick in the hole (without screwing it down).

The level must be between the 2 marks on the gauge (see ZF manual).



- After every 250-hours of use, or once a year depending on the level of use, the boat must be lifted out to change the POD oil.
- During crantage: it is imperative to engage forward gear for several seconds to position the engine base of the boat correctly under the crane before stopping the boat's engine (see the chapter Handling).
- Every 7 years, replace the POD's packing.

8. Dock & Go circuit protection

Lighted safety fuses

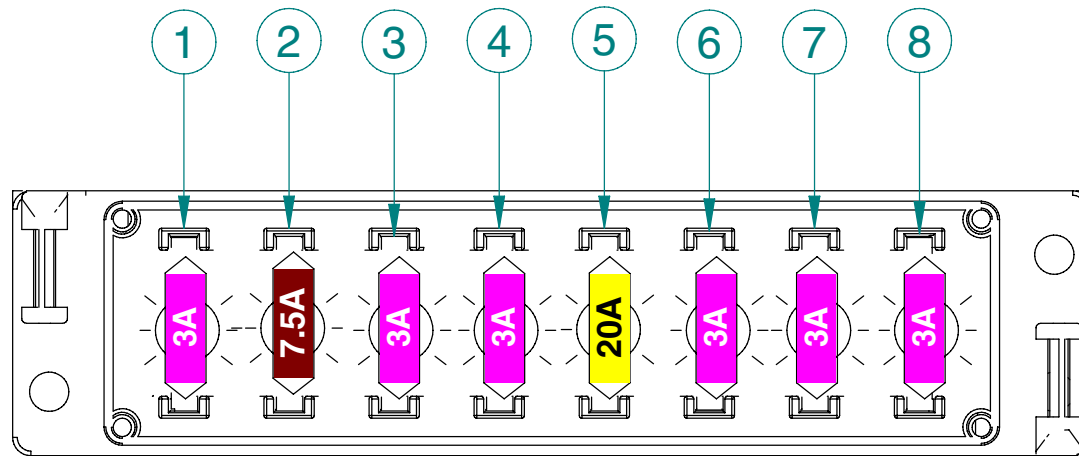

Reference	Designation
1	Supply VHS 1 after engine contact
2	Supply VHS 2 after engine contact
3	VMU power supply VMU
4	VMU power supply TCU 1
5	VMU power supply TCU 2
6	Supply VMU after engine contact
7	Supply TCU after engine contact
8	Supply pod after engine contact

NOTE: If a safety fuse illuminates, this means that it is faulty. In this case the safety fuse must be replaced with a safety fuse of the same rating (see colour codes below).

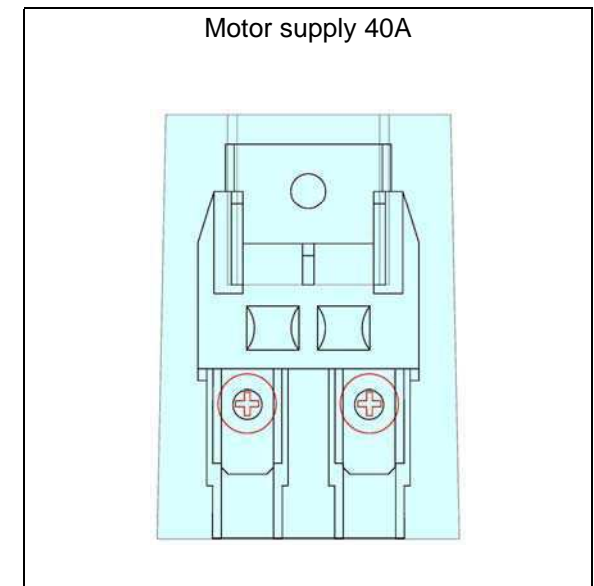

NAVIGATION: REMINDER OF SOME ADVICE

Stability

During sailing keep all the portholes, windows and doors closed.

- The stability is reduced when you add weight in the upper parts.
- Stability may be reduced when towing a boat or when heavy weights are lifted with the davits.
- Breaking waves represent a serious danger for stability and for taking in water. Close the companionway doors and hatches in heavy seas.

Prevention of man overboard

Regularly check the guard-rails:

- With metal guard-rails, watch for corrosion particularly at connecting points.
- With synthetic guard-rails, change them as soon as they show signs of wear due to chafing or UV.

Propeller

The propeller supplied as a standard with your boat is the result of tests carried out jointly with the engine manufacturer.



ADVICE - RECOMMENDATION

- Have the whole driving and steering systems checked and maintained by a professional.
- Refer to the manufacturers' instructions supplied with your boat.
- Regularly check the O ring of the filler for good condition (in order to prevent water entries).
- Do not turn off the fuel tap after each use (except in case the boat is unattended for long).
- Keep the fuel tank as full as possible (to avoid condensation).
- Every year check the fuel system for condition (hose, valves, etc.).
- Have a professional to carry out the works on the damaged parts of the fuel system.
- Refer to the manufacturer's manual given with your boat.
- Be careful with any possible risk of oil and fuel spillage.

Launching

- Launching recommendations
- Stepping the mast

POSITION OF HOISTING CRADLE AND STRAPS

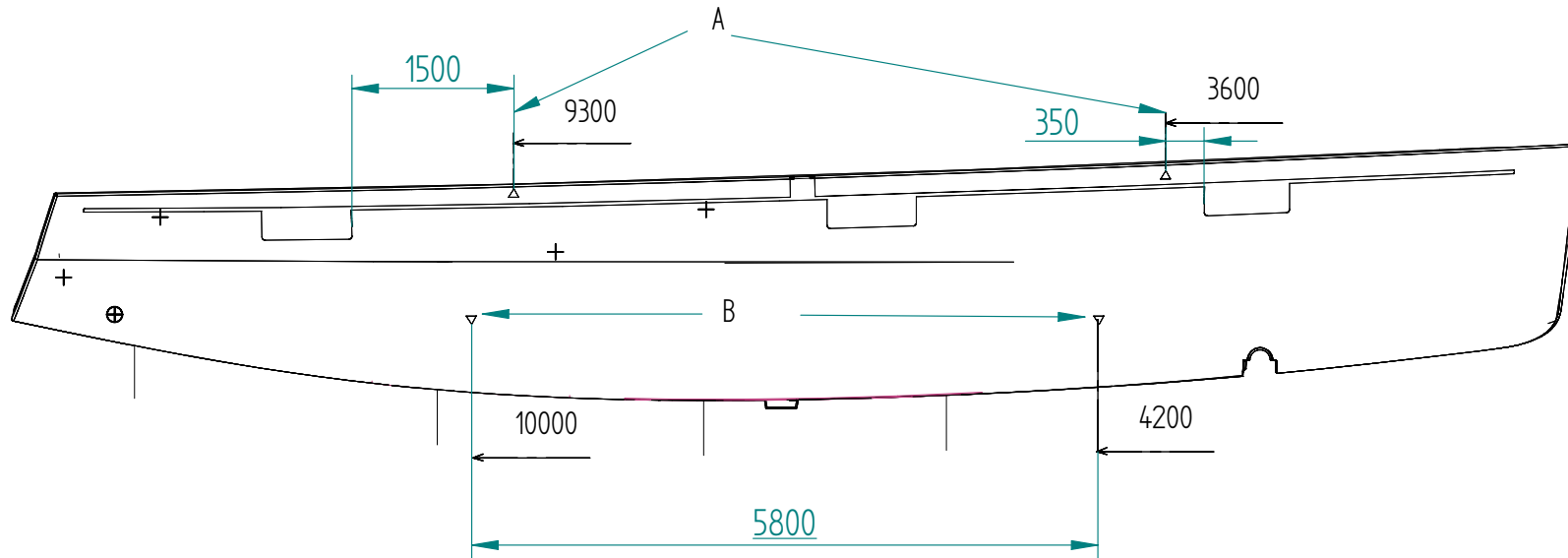

- A. Positioning of hoisting straps
- B. Positioning of launching cradles

Note: Measurements are expressed in mm.

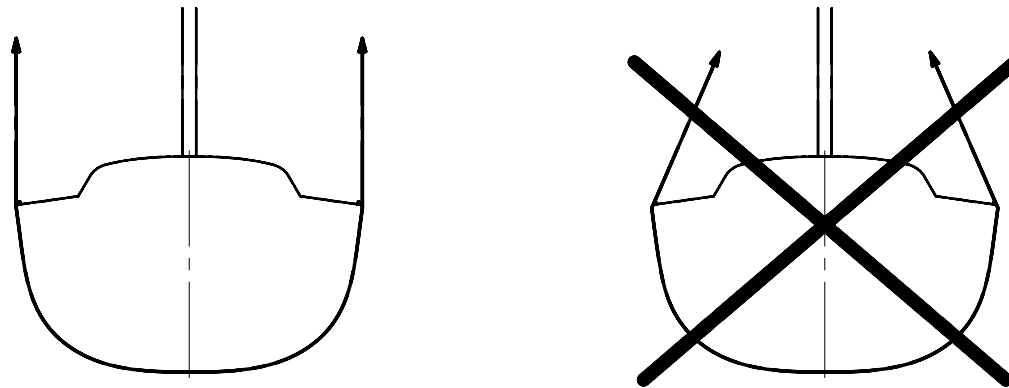

■ LAUNCHING RECOMMENDATIONS.

A lot of skill and care is required to commission your BENETEAU boat. The proper working of all your boat's equipment is the result of the quality of the commissioning operations.

In order to remain completely under guarantee in the case of any failure of parts or materials the first launching and the first trials of different equipment must be carried out by your BENETEAU dealer.

If later you have to launch your boat yourself, you should take the following precautions:

BEFORE LAUNCHING

- If your boat is to be fitted with sounder and speedometer, allow for the relevant fittings and their installation.
- Check the water intake strain box for cleanliness.
- Check the engine and reduction gear oil levels (refer to engine manual).
- Turn off the engine cooling water drain valves.
- Retract the speedometer into its housing (it may be damaged by the handling belts).
- For the on-line engines, check the anode at the end of the shaft is in place. Check the nut tightening (the lock washer shall be turned over onto the nut). The anode shall not be painted.
- Turn off all the water inlet and drain valves (sink, washbasin, heads, engine).

HANDLING

- Install a fore rope, a rear rope and fenders.
- When craning, check that no device is crushed by the belts (sounder, speedometer, shaft, etc.).
- Locate the strap positions using the stick-on markers. The belt position will be useful during the craning for a future launching.



WARNING

-Do not stay on board or under the boat during hoisting.



ADVICE - RECOMMENDATION

-The proper working of all your boat's equipment is the result of the quality of the commissioning operations.



WARNING

Dock & Go version:

Put the control lever in neutral AFTER ENGAGING FORWARD GEAR FOR A FEW SECONDS, so the POD is properly located in the ahead position.

AFTER LAUNCHING

- Check the sounder and speedometer fittings for tightness if need be.
- Open the valves and make sure that they are tight with the hull and relevant hose.

Before starting the engine, refer to chapter 10 "Motor".

■ STEPPING THE MAST

Please contact your dealer.

Winter Storage

- Laying up
- Protection and maintenance

Winter Storage 12

■ LAYING UP.

- Take ashore all the ship's log, the ropes that are not used for mooring, the galley equipment, supplies, clothes, the safety equipment, batteries, the gas cylinder.
- Mark again the safety equipment, check the expiration dates, have the liferaft overhauled.
- Take advantage of this laying up to draw up a complete inventory of the equipment.

■ PROTECTION AND MAINTENANCE.

INTERIOR

- Drain all the fresh water pipes and rinse them with water and vinegar (do not use a chlorine based product).
- Lubricate and close all the water inlet valves and thru-hull fittings. Rinse and completely drain the heads bowls and pumps.
- Remove the depth sounder and log sensors.
- Installed in the square of a dehumidifier air leaving the cabin doors and open storage (cupboards, coolers).
- Leave the cushions outside for long before putting them back into the boat in the upright and side position in order to have minimum contact surfaces.
- During long absence leave the fridge and icebox doors open to avoid mould developing.

EXTERIOR

- Thoroughly rinse the hull and deck.
- Grease all moving and mechanical parts (latches, hinges, locks, etc).
- Protect all ropes and mooring lines against chafing.
- Protect the boat as well as possible with fenders.
- Make sure the boat is properly moored.
- Bring the removable cushions inside (washed with soapy water then dried) when the vessel is unoccupied.

This is not an exhaustive list of recommendations. Your dealer will give you the advice you need and will carry out the technical maintenance of your boat.



ADVICE - RECOMMENDATION

- You alone know all the particularities of your boat and its equipment:
- To lay up your vessel carefully and methodically is the best guarantee to avoid problems when re-fitting out.
- This is not an exhaustive list of recommendations. Your dealer will give you the advice you need and will carry out the technical maintenance of your boat.
- Take advantage of this laying up to draw up a complete inventory of the equipment.

Winter Storage 12

Motor

The engine winterization shall be carried out by a professional. Depending on the boat location, afloat or ashore, winterization is different. Here are a few major tasks to carry out:

Afloat

- Drain the cooling system and fill it with antifreeze.
- Shut off the battery switches, grease the terminals and check the battery voltage.
- Fill the fuel tanks to a maximum in order to avoid condensation.
- Please refer to the engine manual for anything relating to the engine.

Ashore

- Take the batteries ashore and keep them on maintenance charge.
- Change the anode.
- Carry out the winterization operations specified by the manufacturer, keeping in mind that the freeze hazard is more significant when the boat is ashore.
- Slacken the a.c. generator and pump belts.

Personal notes

Dealer stamp

The present document is not contractual and since we constantly desire to improve our models, we reserve the right to modify them without notice.



Code: 134827
Index H