

MARINE SELF-CONTAINED DIRECT EXPANSION AIR CONDITIONING SYSTEMS

Installation Manual



- Models :
- | | |
|-------------|----------------|
| · SC4.2 (Z) | · SC4.2 (Z) DC |
| · SC06 (Z) | · SC06 (Z) DC |
| · SC10 (Z) | · SC10 (Z) DC |
| · SC12 (Z) | · SC12 (Z) DC |
| · SC16 (Z) | · SC16 (Z) DC |

CONTENTS

2

Introduction	3
Safety Precautions	4
Technical Parameters	6
Outline Drawings	10
Installation Overview	11
Blower Rotation	12
Placement of A/C Unit	13
Ducting	14
Seawater System	15
Installation Checklist and Final Inspection	16
Operation Controls and Display Remote	17
Wiring Diagram	19
Troubling Shooting	22

INTRODUCTION

Thank you very much for purchasing our SC series marine self-contained air conditioning unit!

Our company was determined to create an ISO9001 standard unit that surpassed our customer's expectations by using only the best components known to outlast and out perform our vigorous quality standards.

Higher flow, and greater efficiency, reliability and robustness:

- *Super high efficiency, quiet compressor and high velocity ball bearing fan.*
- *Elegant Vimar compatible multi color digital control display, including both heat and cool settings.*
- *Auto speed fan complete with "quiet" low speed mode to ensure a restful sleep.*
- *Extra resilient CuNi condensing coils.*
- *Stainless steel chassis and drain pan combination.*

We are so confident regarding the quality of our units that we are currently the only manufacturer who provides a compressor lifetime warranty!

SAFETY PRECAUTIONS

VERY IMPORTANT SAFETY CONSIDERATIONS

- 1- Never install your air conditioner in the bilge or engine room areas.
- 2- Ensure that the selected location is sealed from direct access to bilge and/or engine room vapors.
- 3- Do NOT terminate condensate drain line within three feet of any outlet of engine or generator's exhaust systems, nor in an engine or generator's compartment housing, nor in a bilge, unless the drain is connected properly to a sealed condensate or shower sump pump.

SAFETY WARNING

- The a/c unit should never be placed such that it can circulate carbon monoxide, fuel vapors or other noxious fumes into the boat's living spaces.
- Do not install or operate a self-contained unit in the engine room or near an internal combustion engine. Failure to follow this precaution could result in serious injury or death.

IGNITION PROTECTION WARNING

- Self-Contained units do NOT meet federal requirements for ignition protection, DO NOT install in spaces containing gasoline engines, tanks, LPG/CPG cylinders, regulators, valves or fuel line fittings. Failure to comply may result in injury or death.
- Installation and servicing of this system can be hazardous due to system pressure and electrical components.
- When working on this equipment, always observe precautions described in the literature, tags and labels attached to the unit.
- Follow all safety codes. Wear safety glasses and work gloves and place a fire extinguisher close to the work area.

PRIOR TO INSTALLATION, Please read these instructions completely and then plan all connections which must be made to the a/c unit including ducting, condensate drain line, seawater inlet and outlet hoses, electrical power connection, location of control and seawater pump placement, to assure easy access for routing and future servicing.

INSTALLATION OVERVIEW:

See Figure 1 for an overview of a typical SC a/c system installation.

BLOWER ROTATION

- Rotate the blower to the direction which allows the most direct airflow discharge through the ducting.
- Loosen the adjustment screw on blower mount ring, rotate blower to desired position, and then tighten adjustment screw (See Figure 2).

PLACEMENT OF A/C UNIT

IMPORTANT INSTALLATION NOTE: The condensate base pan is equipped with vibration isolators installed in the bottom of the pan. These isolators are designed to dampen the vibration caused by the operating A/C unit from transferring into the mounted surface.

- Care must be taken when moving the a/c unit across mounting surfaces as isolators can be damaged.
- Isolators will not normally pull out of pan, but can turn sideways if dragged and may break if excessive dragging occurs.
- Unit must be picked up after moving to allow isolator to reset into well, or vibration isolation will be ineffective.
- The a/c unit must be mounted to a low flat level surface, in bottom of locker, under a bunk or dinette seat or in a similar location.

Please read the safety considerations above and see Figure 1 before mounting unit.

Technical Parameters⁽¹⁻⁴⁾

TECHNICAL PARAMETER LIST 1 (110V / 60Hz / 1 UNIT, AC BLOWER)

Model No.		SC4.2 (Z)	SC06 (Z)	SC10 (Z)	SC12 (Z)	SC16 (Z)
Cooling capacity	Btu/h	4200	6000	10000	12000	16000
Heating capacity	Btu/h	4500	6500	11000	13500	17600
Power source		110V/60HZ/1				
Input power (kW)	Cooling	0.34	0.53	0.81	1.05	1.20
	Heating	0.47	0.69	1.09	1.30	1.59
Amp Draw (A)	Cooling	2.9	4.7	7.1	9.2	10.8
	Heating	4.2	6.0	9.3	11.5	13.9
Air flow(CFM)	H/M/L	250/200/100	300/250/210	350/300/250	400/350/300	500/450/350
Refrigerant		R134a	R410a	R410a	R410a	R410a
Minimum Air Duct size in/(mm)		4/(101)	4/(101)	5/(127)	5/(127)	6/(152)
Minimum Return Air Grille size sq in/(sq cm)		64/(413)	64/(413)	100/(645)	121/(780.5)	144/(929)
Minimum Supply Air Grille size sq in/(sq cm)		16/(103)	20/(129)	20/(129)	25/(161)	36/(232)
Seawater pipe in (mm)		5/8 (16)	5/8 (16)	5/8 (16)	5/8 (16)	5/8 (16)
Net Weight lbs (kg)		29.4 (13.3)	42.5 (19.2)	51.8 (23.4)	55.7 (25.2)	67.4 (30.5)

Technical Parameters (2-4)

TECHNICAL PARAMETER LIST 2 (220V / 60Hz / 1 UNIT, AC BLOWER)

Model No.		SC4.2 (Z)	SC06 (Z)	SC10 (Z)	SC12 (Z)	SC16 (Z)
Cooling capacity	Btu/h	4200	6000	10000	12000	16000
Heating capacity	Btu/h	4500	6500	11000	13500	17600
Power source		220V/60HZ/1				
Input power (kW)	Cooling	0.35	0.54	0.81	1.08	1.21
	Heating	0.48	0.70	1.10	1.32	1.61
Amp Draw (A)	Cooling	1.5	2.4	3.5	4.6	5.6
	Heating	2.2	3.0	4.8	5.8	7.0
Air flow(CFM)	H/M/L	250/200/100	300/250/210	350/300/250	400/350/300	500/450/350
Refrigerant		R134a	R410a	R410a	R410a	R410a
Minimum Air Duct size in/(mm)		4/(101)	4/(101)	5/(127)	5/(127)	6/(152)
Minimum Return Air Grille size sq in/(sq cm)		64/(413)	64/(413)	100/(645)	121/(780.5)	144/(929)
Minimum Supply Air Grille size sq in/(sq cm)		16/(103)	20/(129)	20/(129)	25/(161)	36/(232)
Seawater pipe in (mm)		5/8 (16)	5/8 (16)	5/8 (16)	5/8 (16)	5/8 (16)
Net Weight lbs (kg)		29.4 (13.3)	42.5 (19.2)	51.8 (23.4)	55.7 (25.2)	67.4 (30.5)

Technical Parameters (3-4)

TECHNICAL PARAMETER LIST 3 (110V / 60Hz / 1 UNIT, DC BLOWER)

Model No.		SC4.2 (Z)	SC06 (Z)	SC10 (Z)	SC12 (Z)	SC16 (Z)
Cooling capacity	Btu/h	4200	6000	10000	12000	16000
Heating capacity	Btu/h	4500	6500	11000	13500	17600
Power source		110V/60HZ/1				
Input power (kW)	Cooling	0.32	0.51	0.78	1.01	1.17
	Heating	0.45	0.66	1.05	1.28	1.56
Amp Draw (A)	Cooling	2.8	4.5	6.8	8.8	10.5
	Heating	4.1	5.8	9.1	11.2	13.5
Air flow(CFM)	H/M/L	250/200/100	300/250/210	350/300/250	400/350/300	500/450/350
Refrigerant		R134a	R410a	R410a	R410a	R410a
Minimum Air Duct size in/(mm)		4/(101)	4/(101)	5/(127)	5/(127)	6/(152)
Minimum Return Air Grille size sq in/(sq cm)		64/(413)	64/(413)	100/(645)	121/(780.5)	144/(929)
Minimum Supply Air Grille size sq in/(sq cm)		16/(103)	20/(129)	20/(129)	25/(161)	36/(232)
Seawater pipe in (mm)		5/8 (16)	5/8 (16)	5/8 (16)	5/8 (16)	5/8 (16)
Net Weight lbs (kg)		29.4 (13.3)	42.5 (19.2)	51.8 (23.4)	55.7 (25.2)	67.4 (30.5)

Technical Parameters (4-4)

TECHNICAL PARAMETER LIST 4 (220V / 60Hz / 1 UNIT, DC BLOWER)

Model No.		SC4.2 (Z)	SC06 (Z)	SC10 (Z)	SC12 (Z)	SC16 (Z)
Cooling capacity	Btu/h	4200	6000	10000	12000	16000
Heating capacity	Btu/h	4500	6500	11000	13500	17600
Power source		220V/60HZ/1				
Input power (kW)	Cooling	0.32	0.51	0.78	1.01	1.17
	Heating	0.45	0.66	1.05	1.28	1.56
Amp Draw (A)	Cooling	1.4	2.3	3.4	4.4	5.3
	Heating	2.1	2.9	4.6	5.6	6.8
Air flow(CFM)	H/M/L	250/200/100	300/250/210	350/300/250	400/350/300	500/450/350
Refrigerant		R134a	R410a	R410a	R410a	R410a
Minimum Air Duct size in/(mm)		4/(101)	4/(101)	5/(127)	5/(127)	6/(152)
Minimum Return Air Grille size sq in/(sq cm)		64/(413)	64/(413)	100/(645)	121/(780.5)	144/(929)
Minimum Supply Air Grille size sq in/(sq cm)		16/(103)	20/(129)	20/(129)	25/(161)	36/(232)
Seawater pipe in (mm)		5/8 (16)	5/8 (16)	5/8 (16)	5/8 (16)	5/8 (16)
Net Weight lbs (kg)		29.4 (13.3)	42.5 (19.2)	51.8 (23.4)	55.7 (25.2)	67.4 (30.5)

Outline Drawings

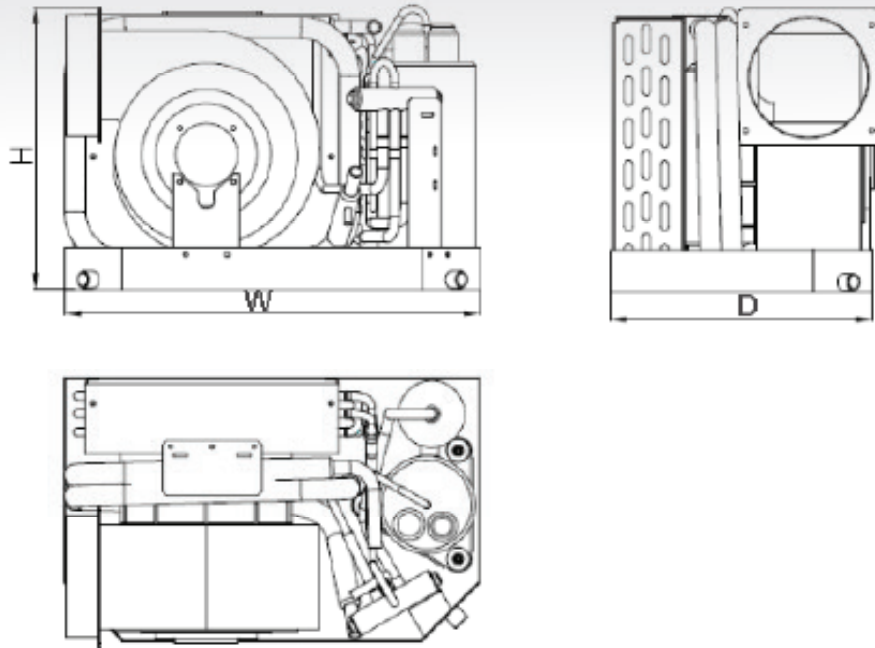

Model No.	W (in/mm)	D (in/mm)	H (in/mm)
4200BTU Model			
SC4.2/SC4.2Z/SC4.2DC/SC4.2ZDC	13.8/330.5	7.5/190.5	9.4/238
6000BTU Model			
SC06/SC06Z/SC06DC/SC06ZDC	15.6/396	9.4/239	11/279.4
10000BTU Model			
SC10/SC10Z/SC10DC/SC10ZDC	18.9/480	11.2/284	11.6/294.6
12000BTU Model			
SC12/SC12Z/SC12DC/SC12ZDC	18.9/480	11.2/284	11.6/294.6
16000BTU Model			
SC16/SC16Z/SC16DC/SC16ZDC	19.5/495	12.4/315	12.9/327.6

Installation Overview

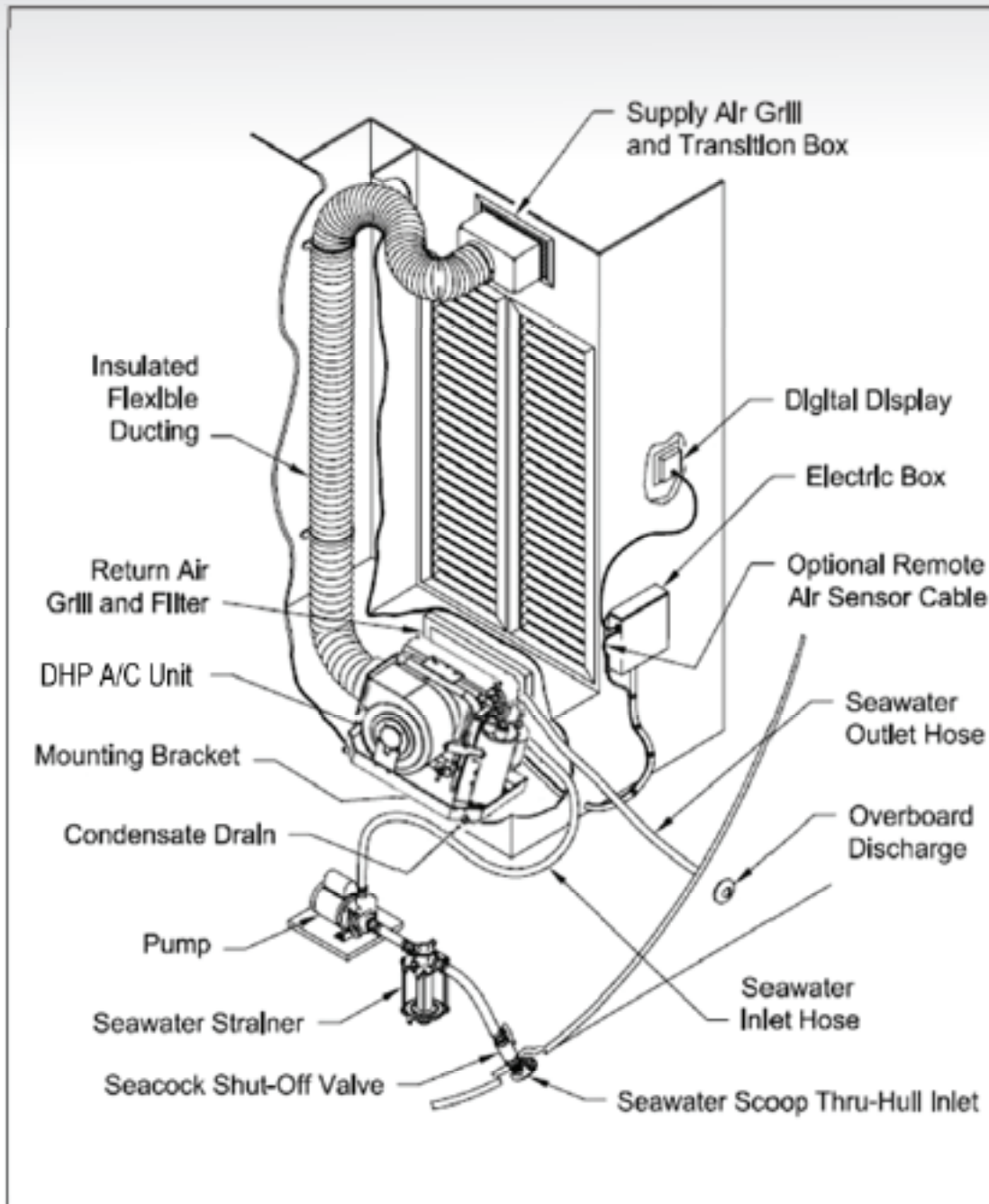
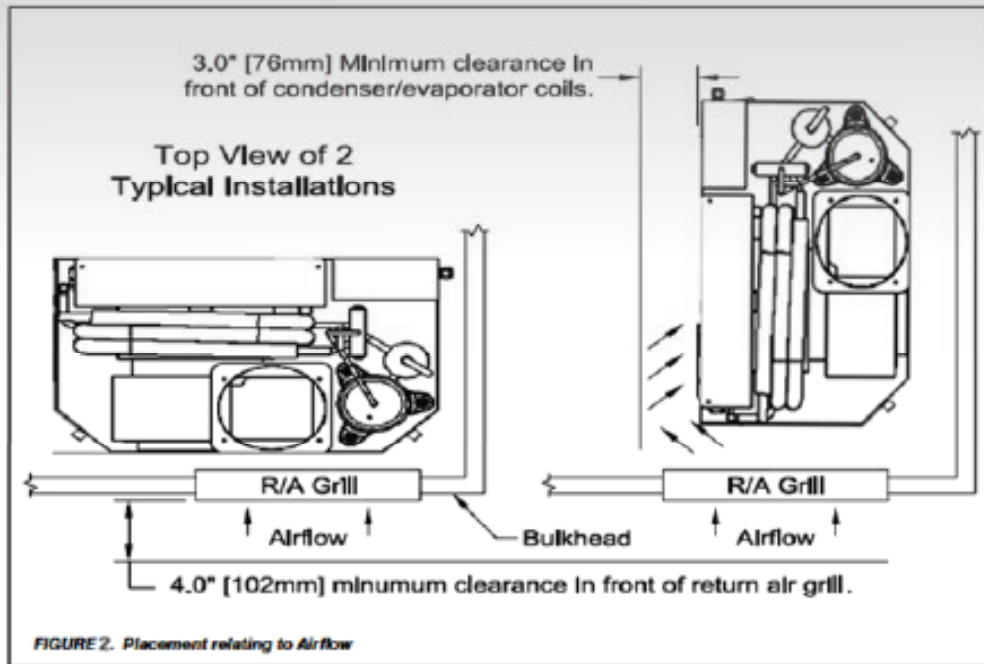

FIGURE (1). Installation overview

Blower Rotation



- Mount unit with condenser/evaporator coil directly behind return air grill or with at least 3" (76mm) of air circulation clearance if adjacent to a bulkhead or other obstructions. See Figure 2.
- Compressor should be mounted away from return air grill if possible to minimize sound level in cabin.

FAN MOTOR ROTATION

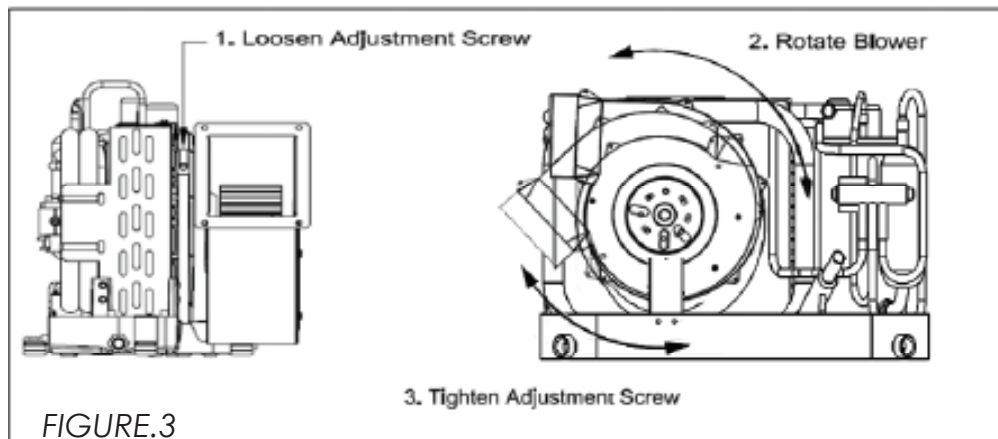

Adjust the air outlet by loosening lock screw and secure the screw tightly once the air outlet is adjusted at the optimal location. See figure 3.

Placement of the A/C unit

NON-SLIP TAPE

Put the attached non-slip tape on the base of the A/C system securely. See figure 4.

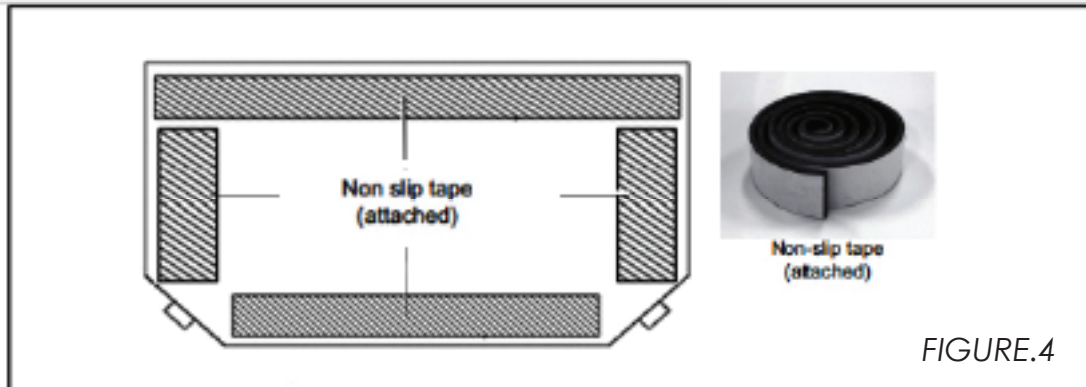

FIGURE.4

NON-SLIP TAPE

The four mounting brackets provided should be placed around edge of drain pan as equally spaced as possible. Secure a/c unit to a flat level mounting surface. Brackets with vibration isolators and sleeves are provided. Customer is to supply screw or bolts. See Figure 5

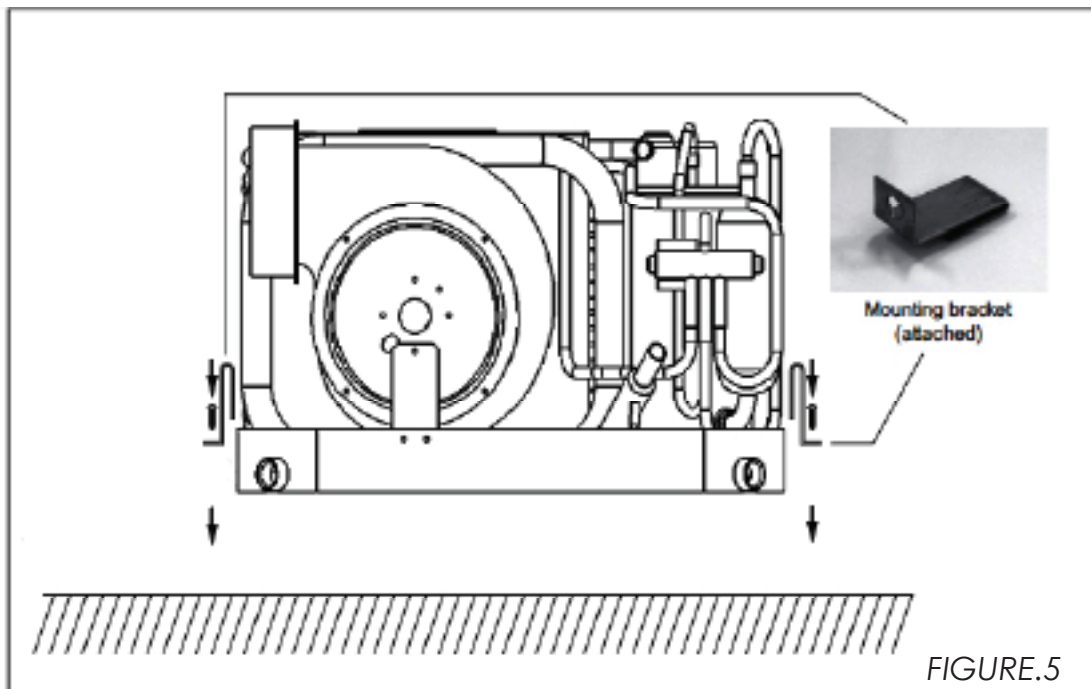

FIGURE.5

DUCTING

Good airflow is critical for the performance of the entire system. It is highly dependent on the quality of the ducting installation.

The ducting should be running as straight, smooth and taut as possible minimizing the number of 90° bends (two 90° bends can reduce the airflow by 25°).

If transition box is used, the total area of supply air ducts going out of the box should at least equals the area of the supply duct going into the box.

ALL DUCTING SHOULD:

- Be appropriately sized for each application.
- Run as smoothly and taut as possible.
- Have as few bends or loops as possible.
- Be securely fastened to prevent sagging during boat operation.
- Have all excess ducting lengths trimmed off.
- Not be flattened or kinked.
- Be Insulated when located in high heat load areas (hull side, mechanical compartments, etc.).
- Be properly protected against potential damage when routed through open areas.
- Do NOT route ducting through engine room or any area where it may be exposed to dangerous vapors or exhaust fumes.

SEAWATER SYSTEM

Several guidelines should be followed during the installation of the seawater system..

If the circulation pump is centrifugal and not self-priming, it must be mounted so that it is always at least one foot below the water line regardless of which tank the vessel is on. Pump may be mounted horizontally or vertically.

The following is a summary of the Seawater System installation:

- Install the seawater scoop thru-hull inlet as close to the keel and as far below the water line as possible, facing forward. Bed the scoop with a marine sealant designed for underwater uses.
- Install a bronze, full flow seacock on the seawater scoop thru-hull inlet.
- Install a seawater strainer below the level of the pump with access to filter.
- Mount the pump above the strainer and at least one foot below the waterline.
- Connect the seacock and the strainer with an uphill to run of reinforced marine grade hose.
- Connect the discharge from the pump uphill to the bottom inlet of the A/C unit's condenser coil with 5/8" (15.9mm) reinforced marine grade hose.
- Connect the discharge from the condenser coil with overboard discharge thru-hull fitting with 5/8" (15.9mm) reinforced marine grade hose.
- Avoid loops, high spots or the use of 90° elbows with seawater hose (each 90° elbow is equivalent to 2.5' (0.762m) of hose and a 90° elbow on the pump outlet is equivalent to 20' (6.1m) of hose).
- Double clamp all hose connections with two stainless steel clamps, reversing the clamps.
- Use threaded seal tape on all threaded connections.
- Connect all metallic parts in contact with seawater to the vessel's bonding system including the speed scoop inlet, strainer, pump and the air conditioner.

SEAWATER SYSTEM

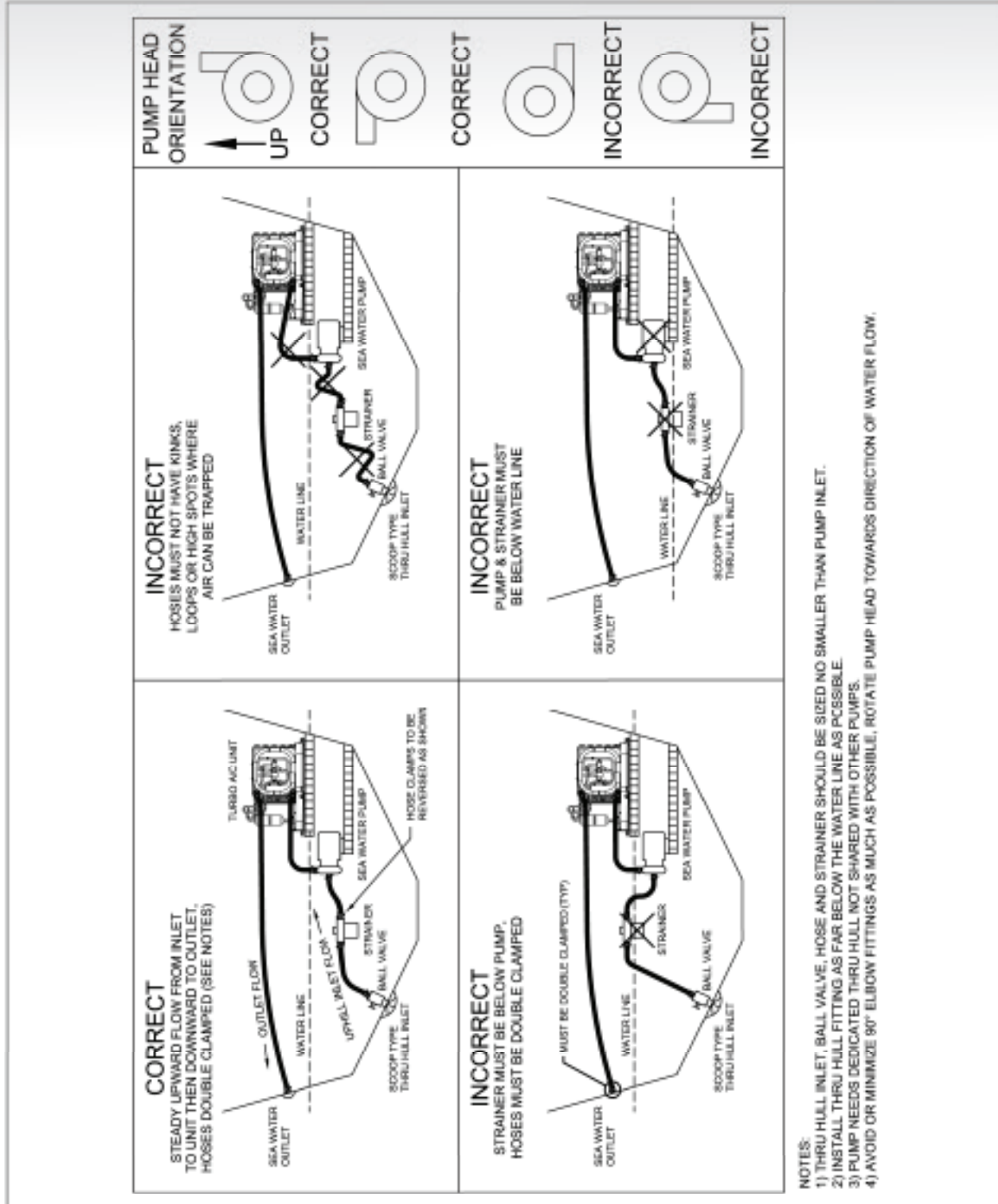

FIGURE 7. Seawater system

INSTALLATION CHECKLIST & FINAL INSPECTION

CHECK THE MARINE AIR CONDITIONER:

- Check for any damage (appearance, inside pipes..etc) when transporting and handling.
- Check if the fan's motor is rotating normally.

CHECK THE PIPING SYSTEM:

- Check if the system's piping and valves are installed correctly.
- Check if the ducts are loosened or not and if its insulations and drains are well done.
- Check if the piping system is clean to avoid any damage to the unit.
- Check if all the opening valves of the system are to be opened and all the OFF valves of the system are to be shut off.

CHECK THE ELECTRICITY:

- Check if the power source matches exactly the rating lable instructions and the operation manual.
- Check if the electricity and control circuit are correctly connected, well grounded and all the terminals are fastened.

REMARK: THE TESTING MUST BE COMPLETED BY A PROFESSIONAL.

OPERATION CONTROLS & DISPLAY REMOTE

The buttons on the wire control are designed to switch the unit ON and OFF, increase/decrease the temperature, set the mode, set the timer, and control the fan's speed.

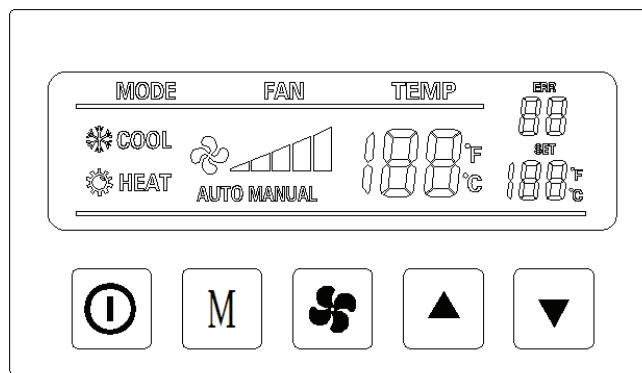

ON/OFF

Press and release to turn the unit ON or OFF.

MODE

Press to choose through the modes of operation, MODE selections are COOL, HEAT and FAN.

FAN

Press to select Automatic or Manual Fan mode, indicated by the AUTO Fan LED indicator being on or off. In Manual Fan Mode, additional presses of the Fan button will adjust fan speed higher, then lower, then back to AUTO. In AUTO Fan, fan speed is controlled by the microprocessor as a function of the difference between set point and inside temperature.

UP

Press and release to display the set point. Press and hold the UP button to increase the set point. Set point increases one degree each time the button is pressed.

DOWN

Press and release to display the set point. Press and hold the DOWN button to decrease the set point. Set point decreases one degree each time the button is pressed.

WIRING DIAGRAM (1)

Models No: SC4.2(Z) - SC06(Z) - SC10(Z) - SC12(Z) - SC16(Z)

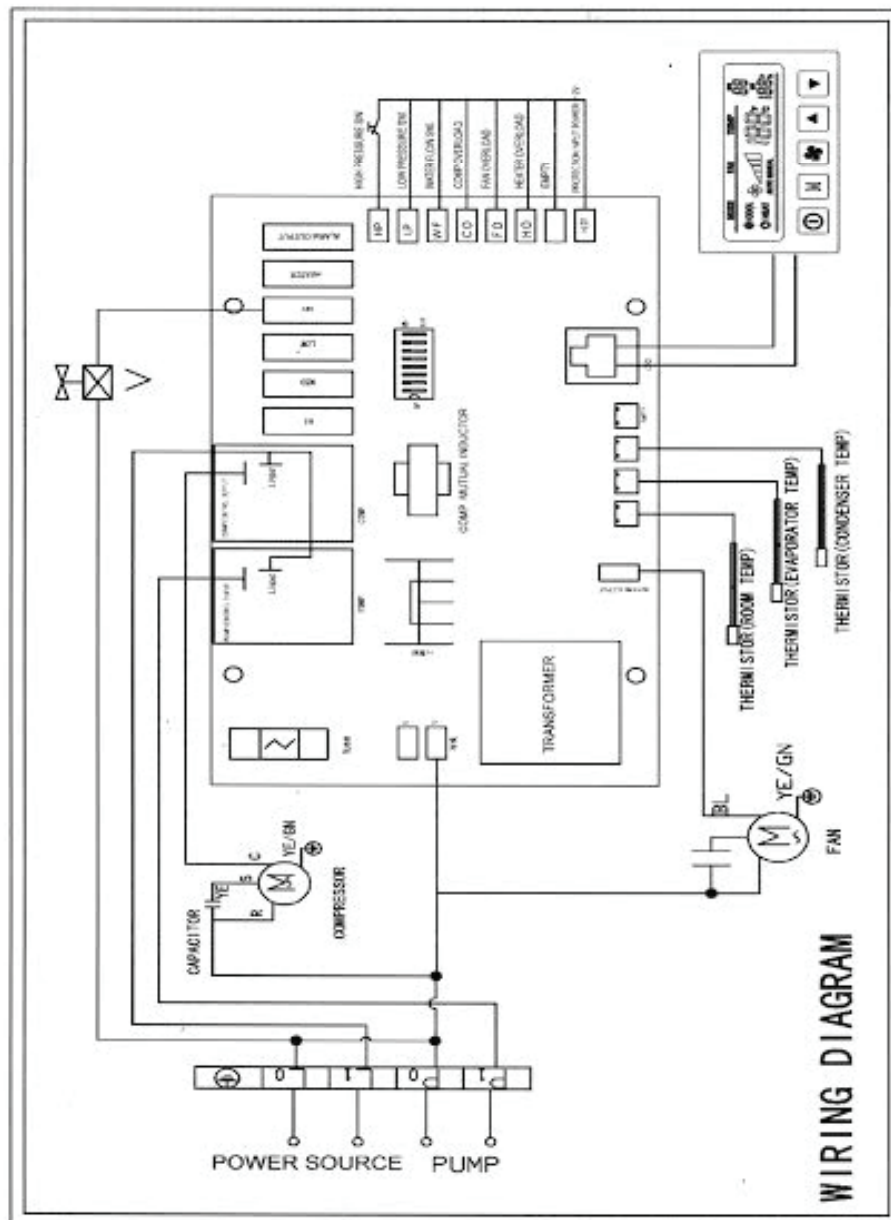

WIRING DIAGRAM (2)

Models No: SC4.2(Z)DC - SC06(Z)DC - SC10(Z)DC - SC12(Z)DC - SC16(Z)DC

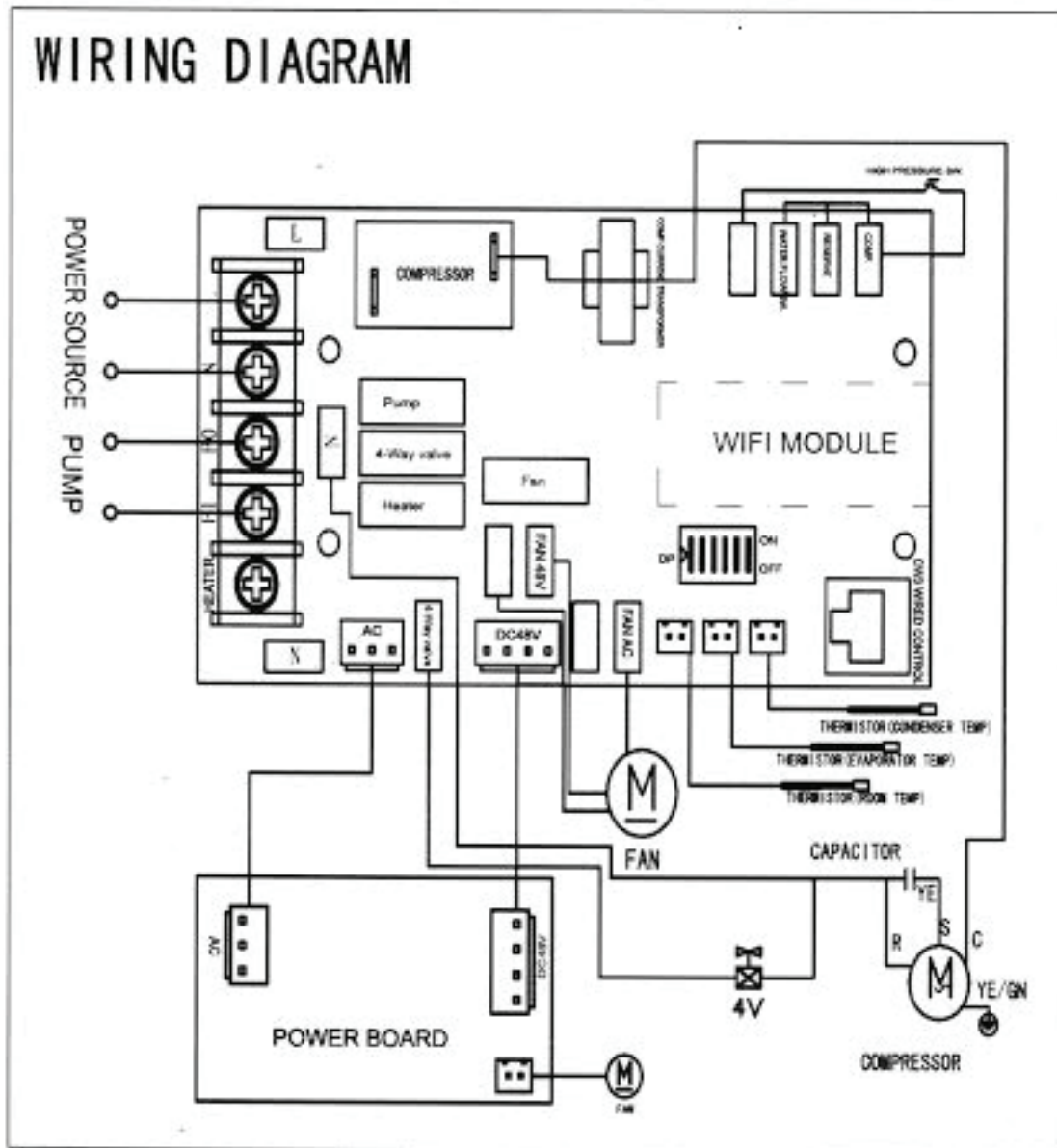

SMART START WIRING DIAGRAM

(OPTIONAL)

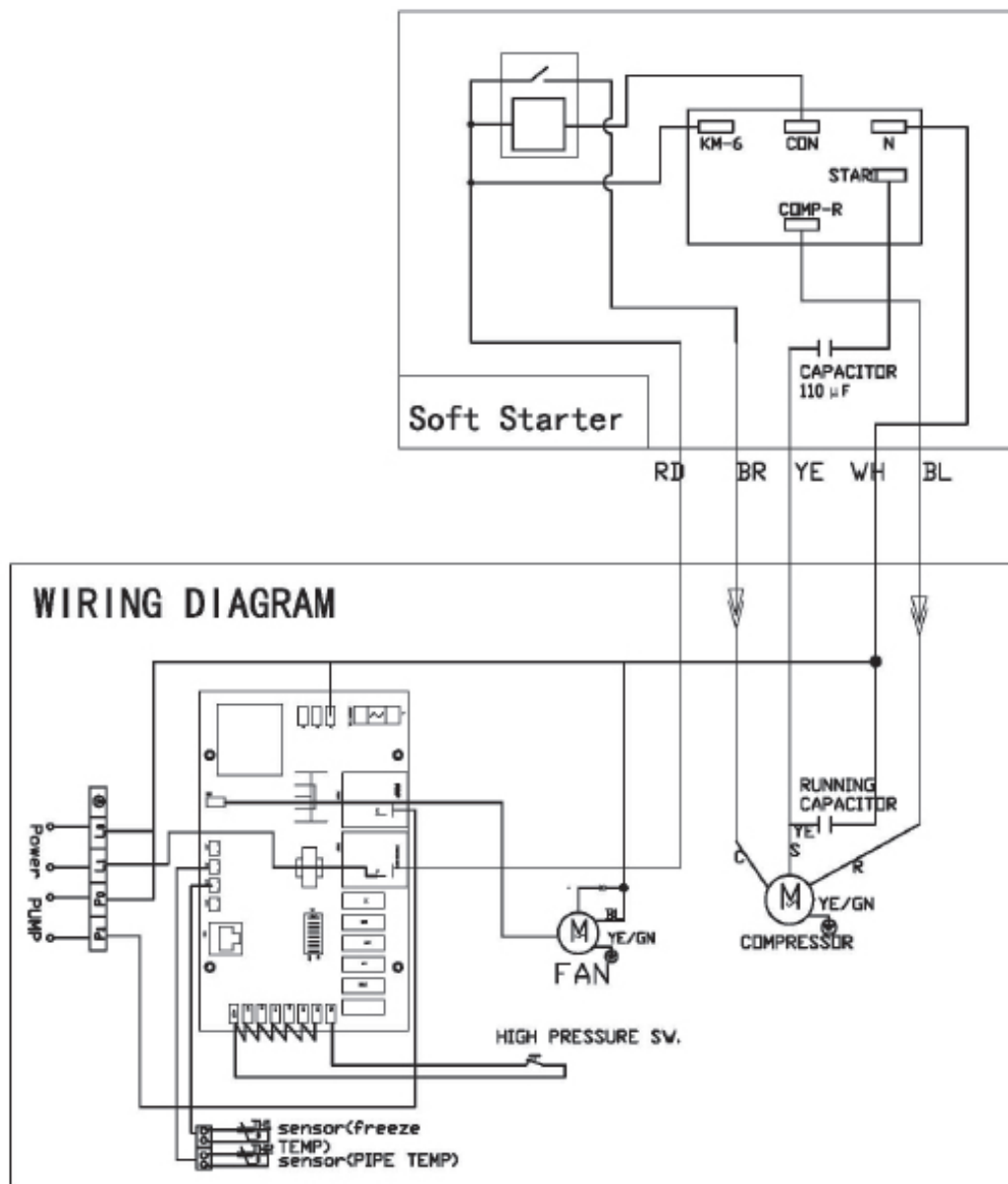

TROUBLE SHOOTING

The PCB controller will estimate the each error which happened in the system operation, and do the treatments according to these error types.

The trouble shootings and errors go into four types, which are the unit resumed protection, system resumed protection, unit serious fault protection, and system serious fault protection.

ERROR CODES TABLE

Error Code	Error Descriptions	Treatments	Resumes
1	Return air temp. sensor error	Shut off the compressor	Automatically resumed
2	Evaporator temp. sensor error	Shut off the compressor	Automatically resumed
3	Circuit water temp. is failing	Shut off the compressor	Automatically resumed
4	Indoor coil sensor is overheating	Shut off the compressor	Automatically resumed
5	Refrigerant gas leakage	Shut off the compressor	Manually resumed
6	Compressor is overloaded	Shut off the compressor	Automatically resumed when unlocked/ Manually resumed when locked
7	Low Pressure protection is shut-off	Shut off the compressor	Automatically resumed when unlocked/ Manually resumed when locked
8	High Pressure protection is shut-off	Shut off the compressor	Automatically resumed when unlocked/ Manually resumed when locked
9	Filter is blocked	Shut off the compressor	Automatically resumed
10	Chilled water temp. protection	Shut off the compressor	Automatically resumed
12	Water flow switch is failing	Stop the machine when it is locked	Manually resumed
13	Communication failure between PCB and central controller	Operate the machine in previous settings, Don't stop the machine	Automatically resumed
15	EEPROM failure	Stop the machine	V
16	Fan motor is over-loaded	Shut off the compressor	Automatically resumed when unlocked/ Manually resumed when locked

ERROR CODES TABLE

Error Code	Error Descriptions	Treatments	Resumes
18	Input the primary password by user	Stop the machine, input the correct passwords (if it is beyond three times, password will be locked, the errorcode 20 displays, you should input the super password for unlocking).	Automatically resumed when unlocked/ Manually resumed when locked
19	Input the secondary password by user	Stop the machine, input the correct passwords (if it is beyond three times, password will be locked, the errorcode 20 displays, you should input the super password for unlocking).	Manually resumed
20	Password is locked	Stop the air conditioner (input super password).	Manually resumed
31	Communication failure between PCB and wireless controller	Operate the machine in previous settings. Don't stop the machine	Automatically resumed
N/M	Password on boot	Stop the machine, input the correct passwords (if it is beyond three times, password will be locked, the errorcode 20 displays, you should input the super password for unlocking).	Manually resumed

Mabru Power Systems cannot accept responsibility for possible errors in catalogs, brochures and other printed material.

Mabru Power Systems
1105 Old Griffin Rd. | Dania Beach, FL 33004
Tel: 954-467-1770
Email: sales@mabrumarine.com

www.mabrumarine.com

