

Hunter 31

SPECIFICATIONS

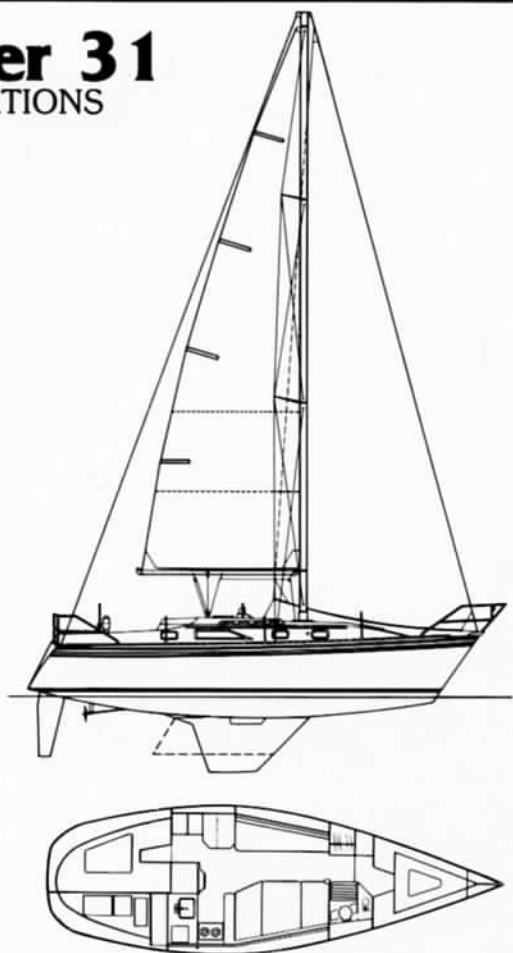

L.O.A.	31'4"	9.55m.
L.W.L.	26'3"	8.00m.
Beam	10'11"	3.33m.
Draft: Shoal	4'0"	1.22m.
Deep	5'6"	1.68m.
Displacement: Shoal	9,900 lbs.	4,494.6 kg.
Deep	9,700 lbs.	4,403.8kg.
Ballast: Shoal	4,200 lbs.	1,906.8 kg.
Deep	4,000 lbs.	1,816 kg.
Mast height	41'5"	12.62m.
from waterline	47'4"	14.43m.
Headroom	6'3"	1.90m.
Sail area	458 sq. ft.	42.55 sq. m.
E (Mainsail foot)	11'0"	3.35 sq. m.
J (Foretriangle base)	12'0"	3.66m.
P (Mainsail luff)	37'5"	11.40m.
I (Foretriangle ht.)	42'0"	12.80m.

Hunter 31

AC/DC ELECTRICAL DIAGRAM

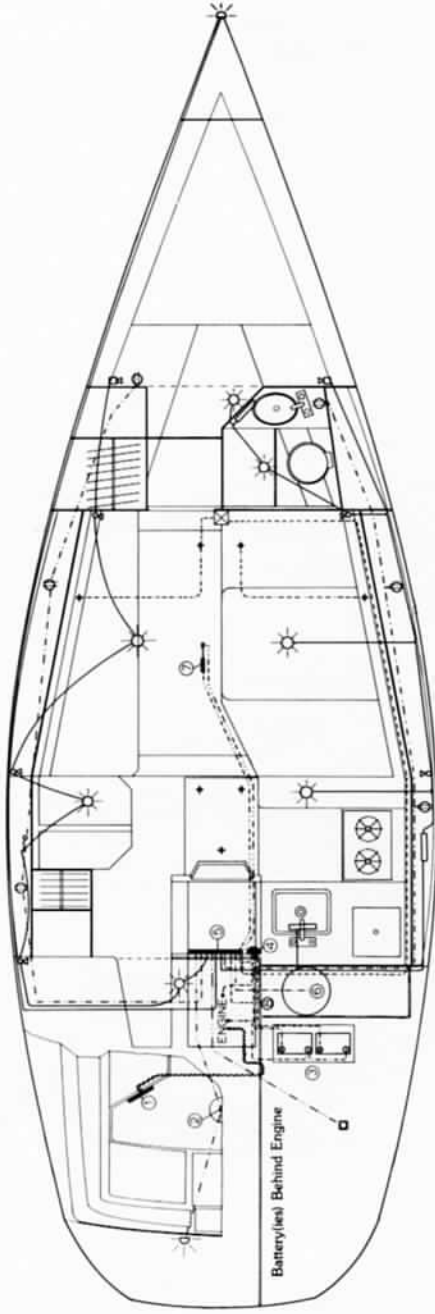

LEGEND:

- ① ENGINE IGNITION PANEL
- ② COMPASS LIGHT
- ③ BATTERIES
- ④ SAFETY MAIN SWITCH
- ⑤ SWITCH PANEL
- ⑥ WATER HEATER
- ⑦ BILGE PUMP W/AUTOMATIC FLOAT SWITCH
- ⑧ PRESSURIZED WATER PUMP

SYMBOLS:

- ☒ MAST
- ☑ SHORE POWER INLET
- ⊕ 110V OUTLET
- ☀ ROUND CABIN LIGHTS (LG)
- ☀ ROUND CABIN LIGHTS (SM)
- ☀ WHITE CABIN LIGHTS
- ⊗ SINGLE LIGHT (SILVER)

Continued on next page

Hunter 31

ELECTRICAL DIAGRAM CONTINUED



WIRING NOTES:

COLOR:	GAUGE:	APPLICATION:
RED	16	ANCHOR LIGHT
GREEN	16	STEAMING LIGHT
BLUE	16	CABIN LIGHTS
WHITE	16	BOW LIGHT
BROWN	12	PRESSURIZED WATER PUMP
BEIGE	12	BILGE PUMP
RED	10	SAFETY MAIN SWITCH TO INLINE FUSE AT PANEL,
BLACK	8	PANEL TO AUTOMATIC FLOAT SWITCH AT BILGE PUMP
RED	4	DC SUPPLY TO PANEL
		MAST AND CHAINPLATE GROUNDS
		BATTERY CABLES

ALL LEADS EXCEPT FLOAT SWITCH, MAST GROUND, AND CHAINPLATE GROUNDS ARE RUN WITH A BLACK WIRE OF EQUAL GAUGE. THESE ARE CONNECTED TO A COMMON GROUND AT THE SWITCH PANEL WHICH IS GROUNDED TO THE ENGINE WITH A 10 GAUGE BLACK WIRE.

WIRE HARNESS TO MAST CONSISTS OF ONE (1) RED (ANCHOR LIGHT) AND ONE (1) GREEN (STEAMING LIGHT) 16 GAUGE WIRE.

Hunter 31

PLUMBING DIAGRAM

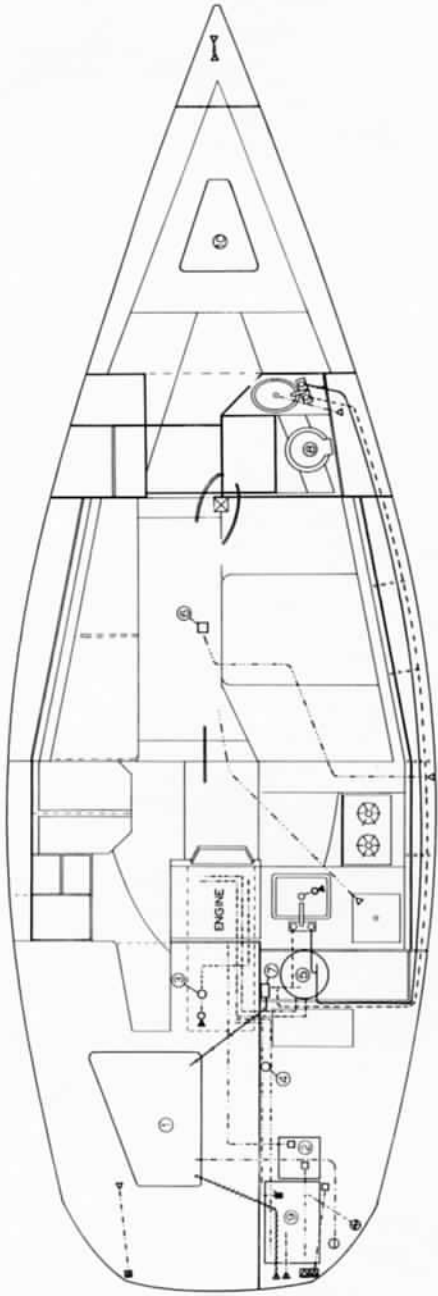

LEGEND:

- ① WATER TANK 33 gi
- ② WATERLOCK (MUFFLER)
- ③ SEA STRAINER
- ④ FUEL FILTER
- ⑤ WATER HEATER
- ⑥ ELECTRIC BILGE PUMP

- ⑦ PRESSURIZED WATER PUMP
- ⑧ HEAD
- ⑨ FUEL TANK 18 gi
- ⑩ HOLDING TANK 20 gi
- ⑪ VENTED LOOP
- ⑫ MANUAL WASTE PUMP

SYMBOLS:

- ▲ THRU HULL (PLASTIC)
- ▲ THRU HULL (BRONZE)
- ▲ VENT
- GATE VALVE
- SCUPPER TUBE

Continued on next page

Hunter 31

PLUMBING DIAGRAM CONTINUED

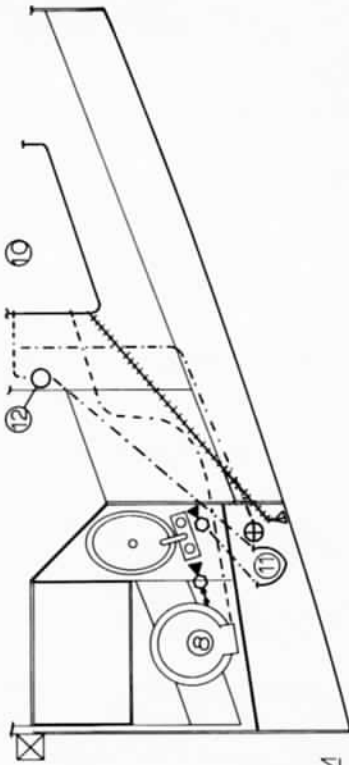

HEAD PLUMBING DIAGRAM

- ☒ THRU HULL SCUPPER TUBE
- ⊕ WATER FILL DECK PLATE
- ⊕ WASTE DECK PLATE
- ⊕ FUEL FILL DECK PLATE
- ☒ FUEL SHUTOFF VALVE
- ☒ MAST POST
- COLD WATER (POLYBUTYLENE TUBING 3/8" ID x 1/2" OD)
- HOT WATER (POLYBUTYLENE TUBING 3/8" ID x 1/2" OD)
- 1-1/2" FUEL FILL HOSE
- 2" SHIELDSAUST HOSE

- 1-1/2" SHIELDVAC HOSE W/CUFFS
- 1-1/4" SHIELDVAC HOSE W/CUFFS
- 1" SHIELDVAC HOSE W/CUFFS
- ++++ 3/4" SHIELDVAC HOSE W/CUFFS
- 1-1/2" SHIELDFLEX HOSE
- 5/8" SHIELDFLEX HOSE
- 3/4" BLACK WATER HOSE
- 5/8" WHITE HOSE W/BLUE TRACER
- FUEL FEED & OVERFLOW HOSE
- POLYBUTYLENE TUBING DRAINS