

CHAPTER 15

DISASSEMBLY AND REASSEMBLY (Fresh Water Cooling Engine)

- 1. Disassembly of Fresh Water-Cooled Engine15-1
- 2. Reassembly of Fresh Water-Cooled Engine15-11
- 3. Tightening Torque15-21
- 4. Packing Supplement and Adhesive Application Point15-24

1. Disassembly of Fresh Water-Cooled Engine

In general, the disassembly sequence for a fresh water-cooled engine is the same as that for a sea water-cooled engine, except that the sequence for parts related to the

cooling water system are slightly different. Refer to the disassembly section of the sea water-cooled engine manual for the latter steps.

1-1. Draining the cooling water

- (1) Drain the sea water from the heat exchanger. The sea water drain cock is installed on the side cover of the heat exchanger at the rear.

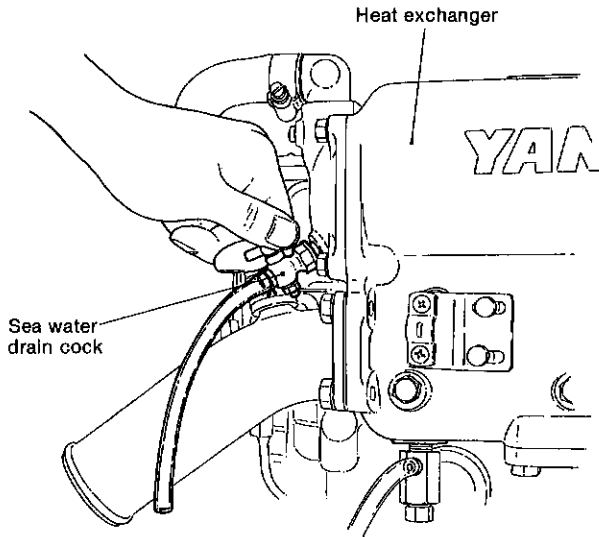

- (2) Drain the fresh water from the heat exchanger. Loosen the fresh water drain plug installed at the bottom of the heat exchanger.

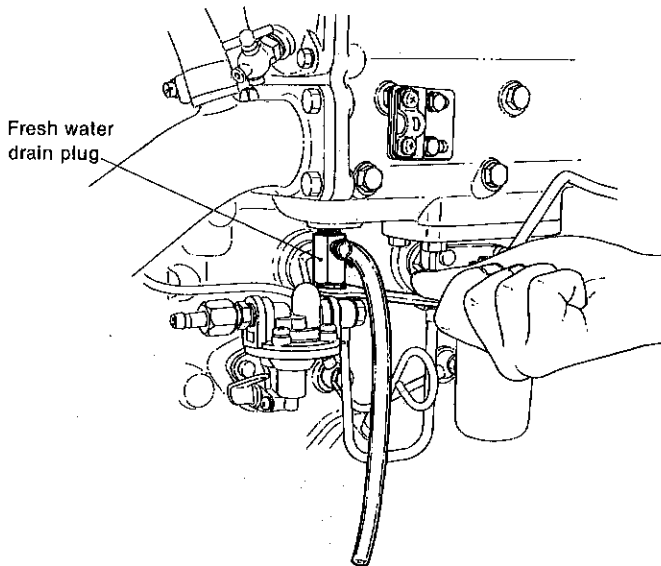

- (3) Drain the fresh water from the cylinder block. Loosen the cylinder block water drain plug and drain the fresh water. The water drain plug is installed on the block wall surface at the exhaust side in a model 2GM20F engine, and on the block wall surface at the intake side in models 3GM30F and 3HM35F engines.

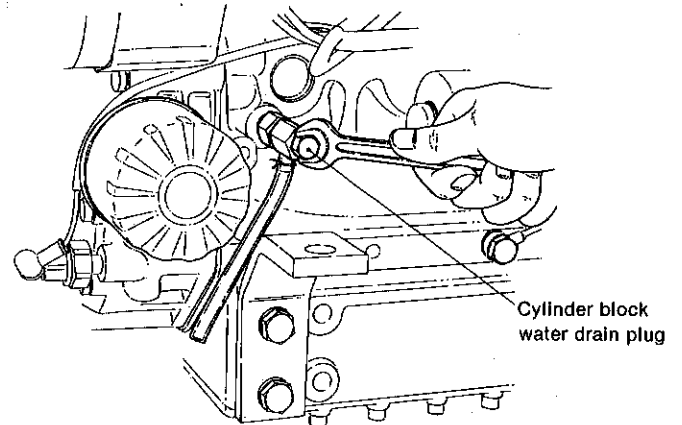
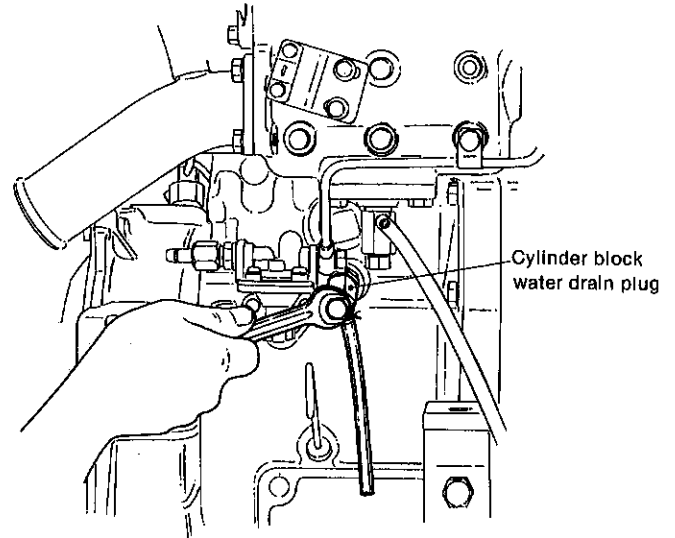

- (4) Draining sea water from the CSW pump
Loosen the CSW pump cover fixing screws, and drain the sea water from the CSW pump and CSW hose.

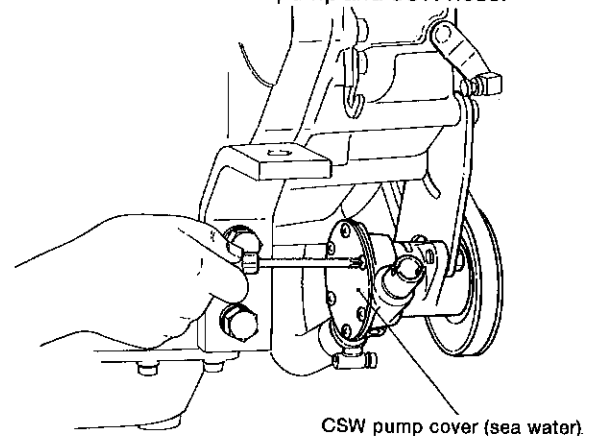

NOTE: CSW = Cooling Sea Water

1-2. Drain the lubricating oil

(1) Engine side

Insert a suction tube into the dipstick hole and pump out the oil with a waste oil pump (option).

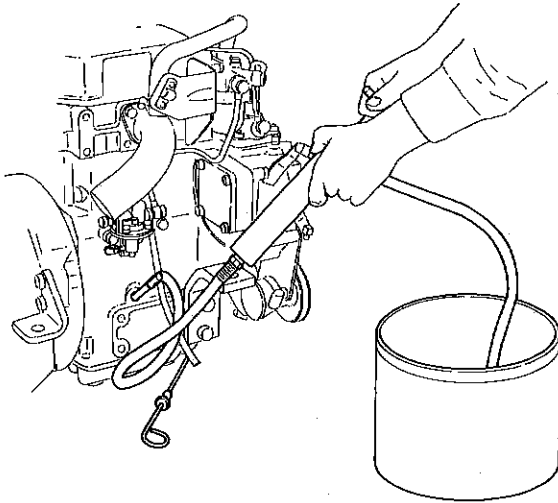

(2) Clutch side

Pump out the oil from the filler/dipstick hole using a waste oil pump or remove the drain plug at the bottom stem side of the clutch case and drain the oil.

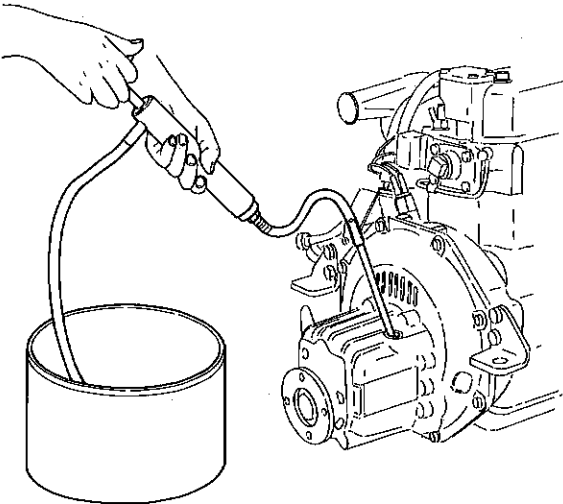

1-3. Disconnect the remote control cables

- (1) Clutch remote control cable
- (2) Speed remote control cable
- (3) Engine stop remote control cable
- (4) Decompression remote control cable

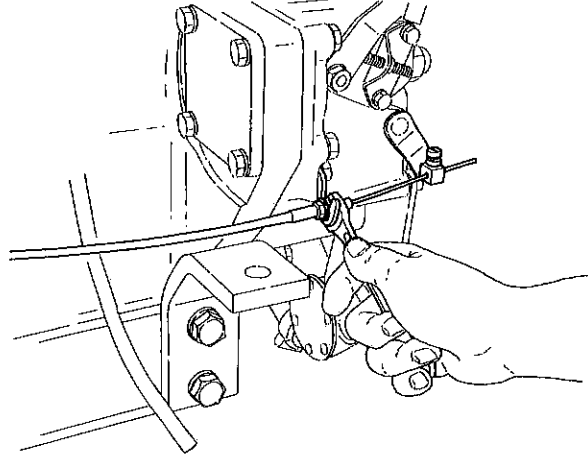

1-4. Disconnect the electrical wiring

- (1) Alternator wiring
- (2) Starter motor wiring
- (3) Water temperature switch wiring
- (4) Oil pressure switch wiring
- (5) Tachometer sender wiring

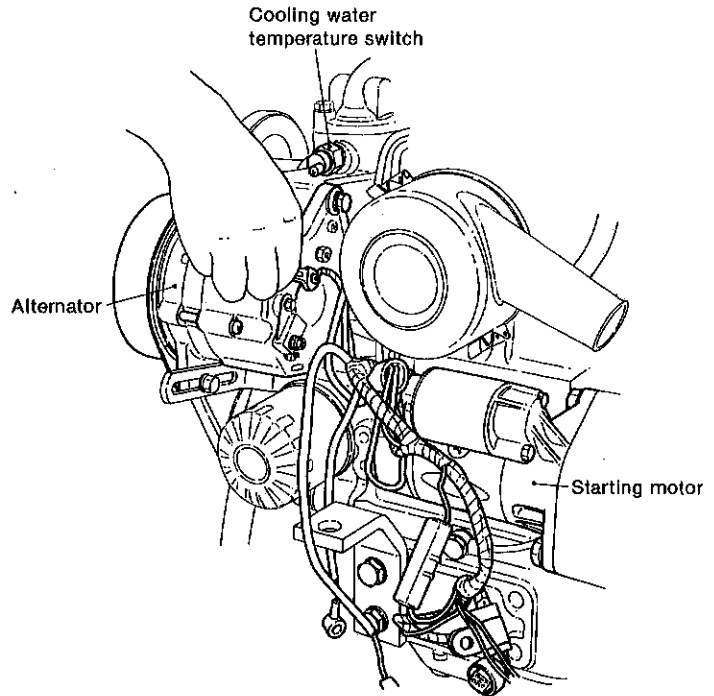

1-5. Remove the CSW hose

- (1) Remove the CSW hose between the CSW pump and heat exchanger.

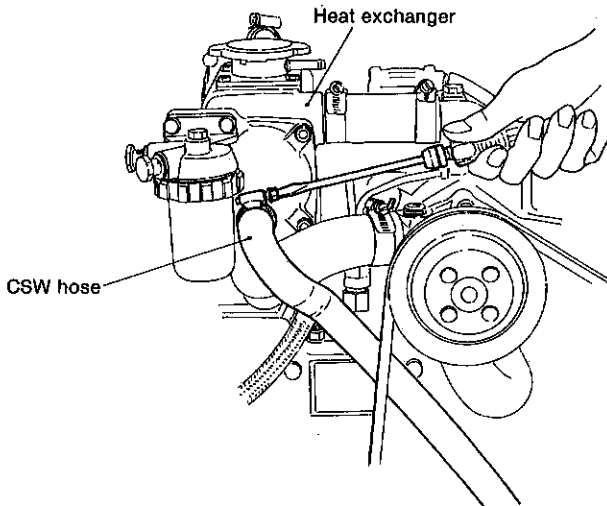

- (2) Remove the CFW hose between the heat exchanger and CFW pump.

NOTE: CFW = Cooling Fresh Water

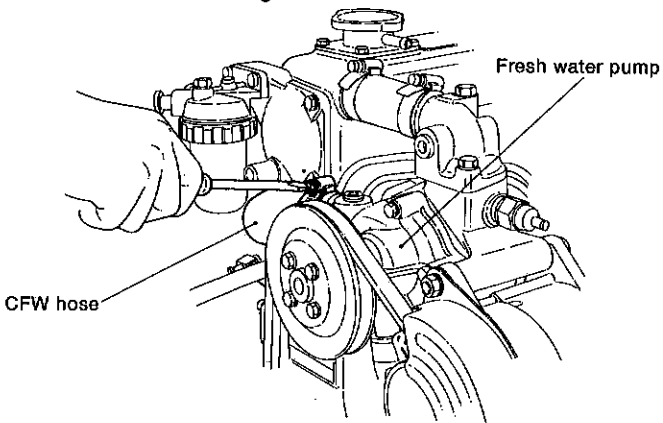

- (3) Loosen the hose clamp on the CFW hose between the cylinder head and heat exchanger. The hose clamp at the heat exchanger side or the cooling water outlet connection side only need be loosened.

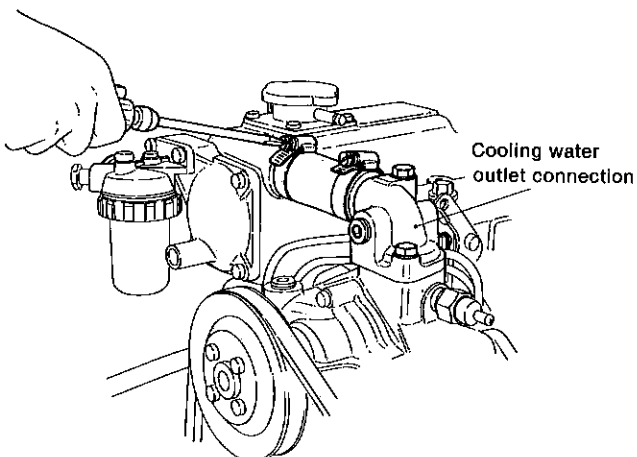

1-6. Disconnect the fuel piping

- (1) Fuel tank to feed pump
(2) Feed pump to fuel filter
(3) Fuel filter to fuel injection pump

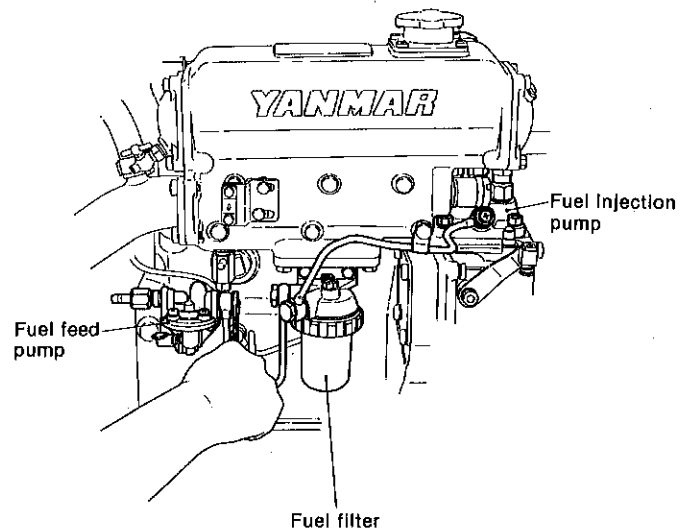
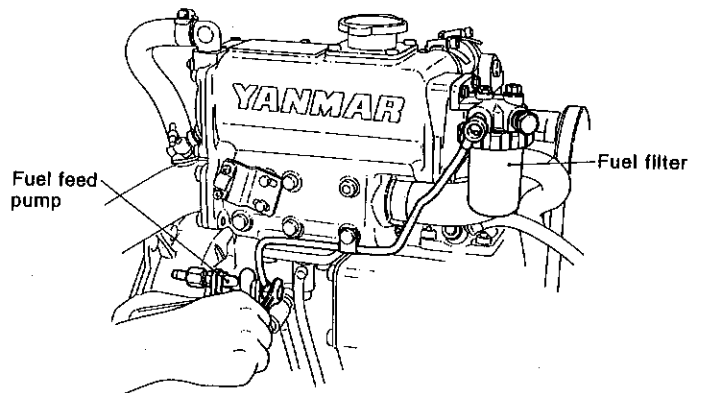
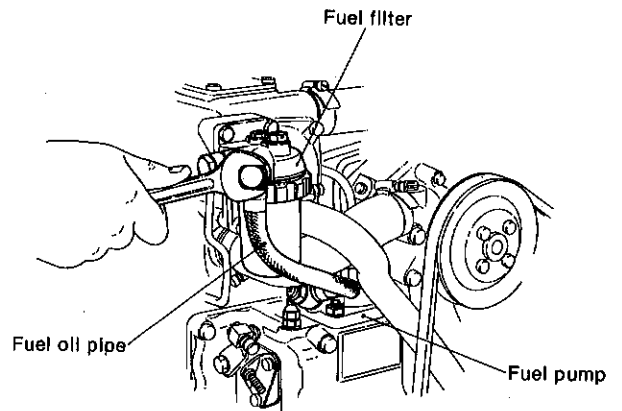

1-7. Removing the fuel filter

The fuel filter can be removed as assembled on the heat exchanger. However, to make removal of the heat exchanger easier, the filter should be removed separately.

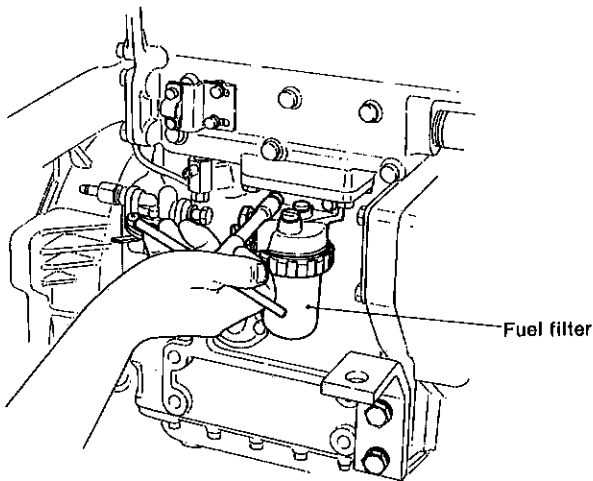

1-8. Remove the fuel feed pump

In cases of model 3GMF, the heat exchanger drain plug may jam against the fuel feed pump pipe connector. The fuel feed pump should be removed before removing the heat exchanger.

In cases of models 2GMF and 3HMF, the heat exchanger can be removed without removing the fuel feed pump.

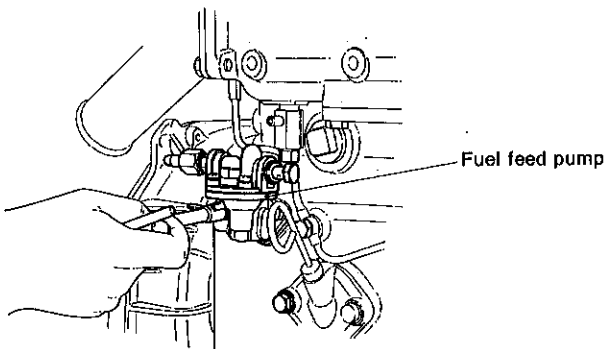

1-9. Remove the remote control bracket

The heat exchanger fixing nut cannot be removed without first removing the remote control bracket.

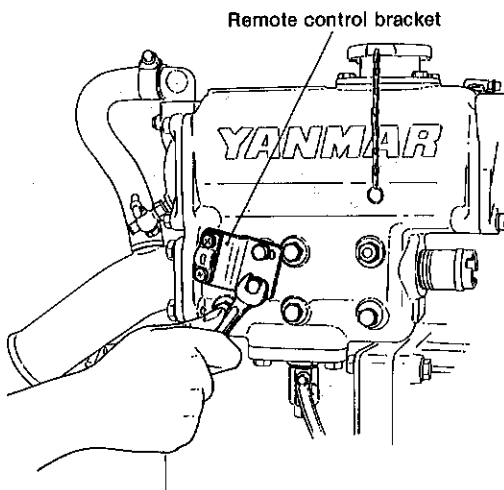

1-10. Remove the heat exchanger.

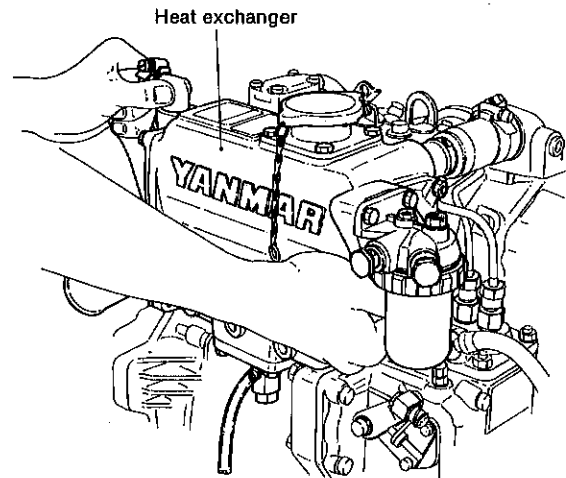

1-11. Remove the alternator

- (1) Loosen the adjusting bolt and remove the V-belt
- (2) Remove the alternator

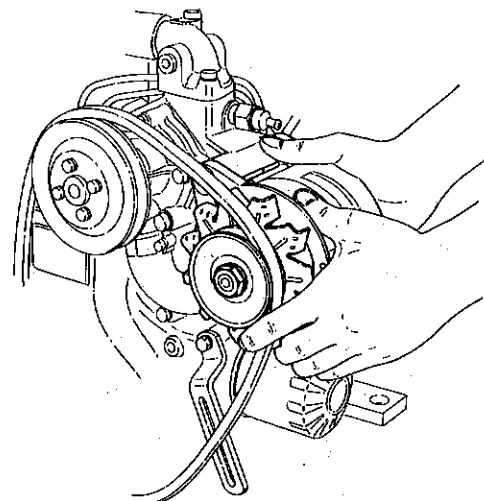
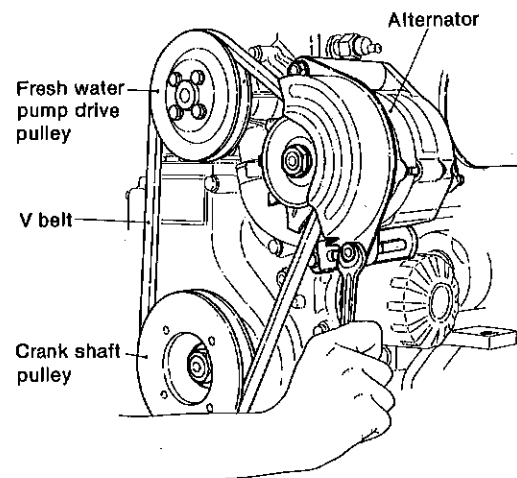

1-12. Remove the CFW pump

Remove the CFW pump by loosening the hose clamp on the CFW hose between the CFW pump and cylinder block at the cylinder block end.

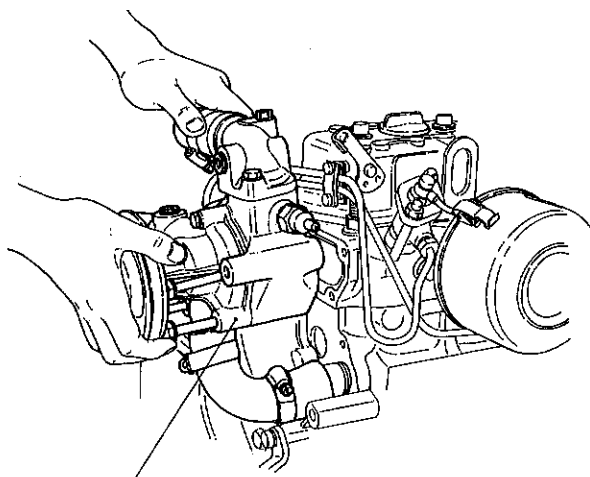

Fresh water pump

1-13. Remove the air intake silencer

Remove the intake silencer clip and the filter element. Then remove the set screw and the cover.

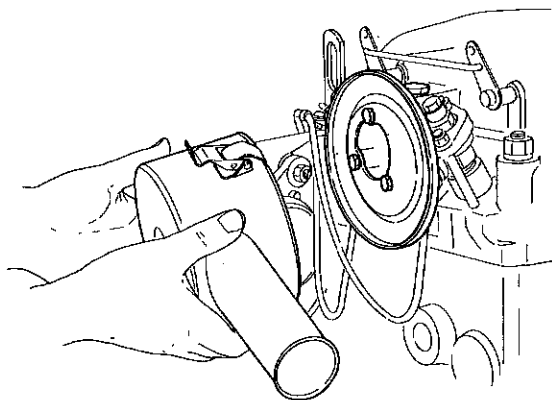

1-14. Remove the fuel high pressure pipe and fuel return pipe.

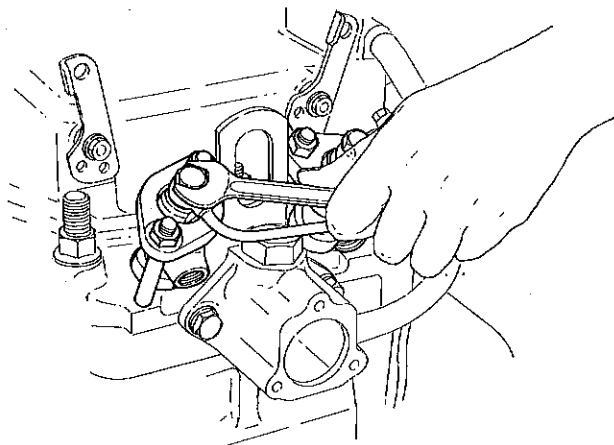

1-15. Remove the starter motor

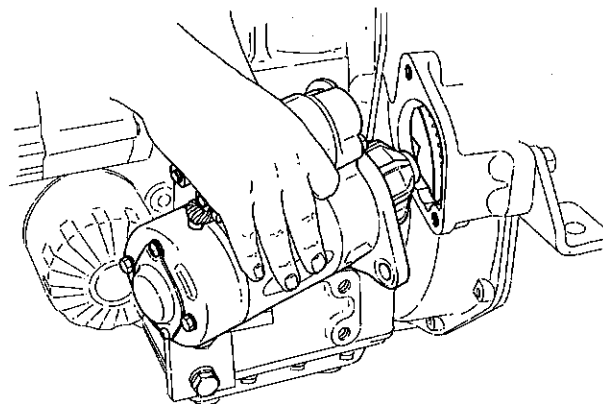

1-16. Remove the oil filter

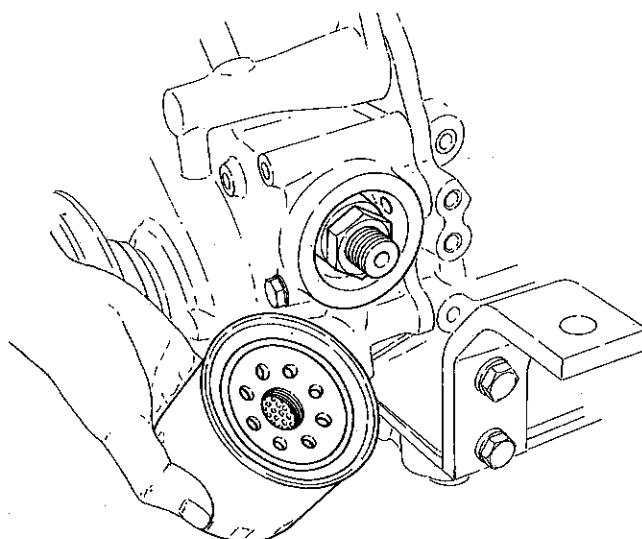

1-17. Remove the CSW pump

Loosen the water pump mounting bolts, remove the V-belt by sliding it toward the crankshaft side, and remove the sea water pump.

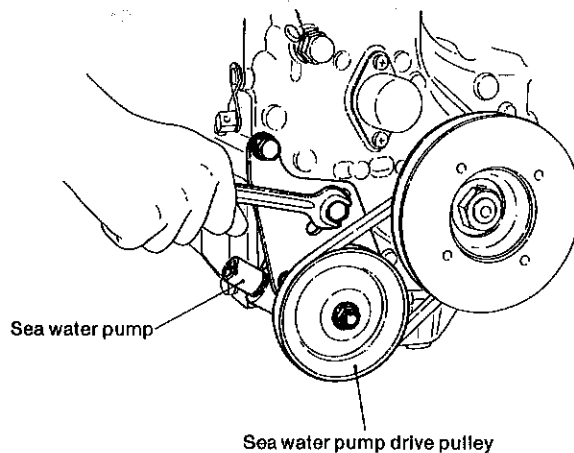

1-18. Remove the rocker arm chamber

- (1) Remove the breather pipe at the side of the intake pipe
[intake manifold for model 3GM30F and 3HM35F]
- (2) Remove the rocker arm chamber

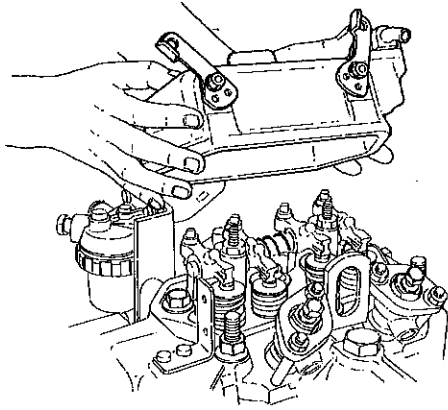

After this step disassembly is carried out in the same sequence as for the sea water-cooled engine.

The details are given in Section 4.3.14 "Remove the rocker arms" P14-23 of the sea water-cooled engine manual.

For reference

4-3.14 Remove the rocker arms

- (1) Remove the mounting nut and remove the rocker arm shaft assembly.
- (2) Pull the push rods.

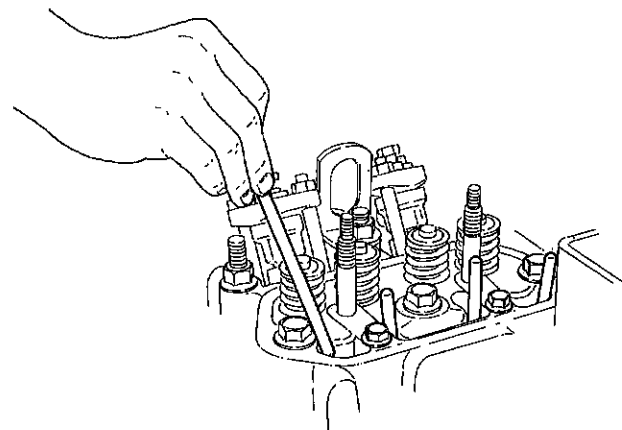
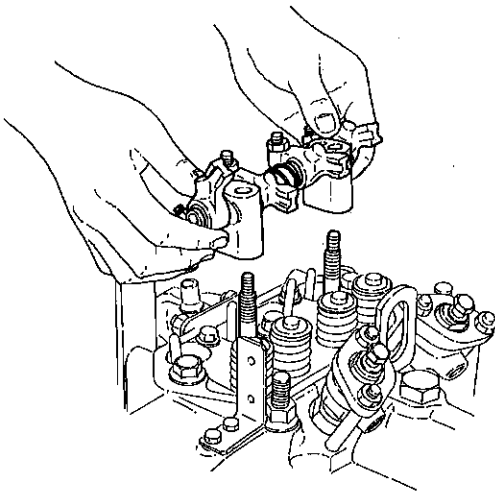

- (3) Remove the cotter pins of the intake and exhaust valve springs.

NOTE: Arrange the parts by cylinder no., intake and exhaust.

4-3.15 Remove the cylinder head

- (1) Disconnect the lubricating oil pipe.
- (2) Remove the cylinder head nuts in the prescribed order, and remove the cylinder head.
- (3) Remove the gasket packing.

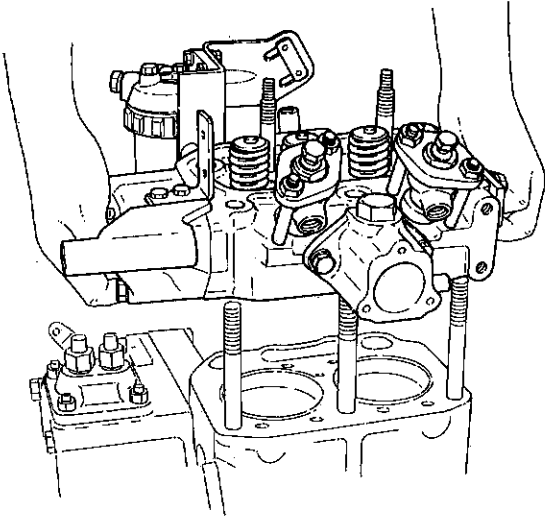

NOTE: Clearly identify the front and back of the gasket packing.

4-3.16 Remove the crankshaft pulley

Remove the crankshaft pulley end nut and remove the V-pulley and key.

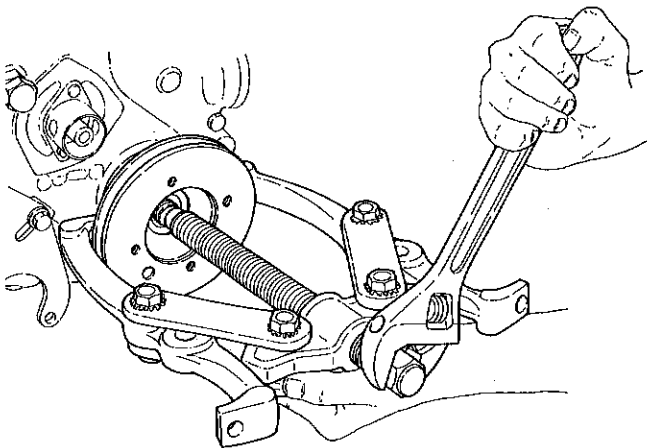

4-3.17 Remove the injection pump

- (1) Remove the injection pump nut.
- (2) Remove the gear case side cover, move the governor lever 2, take out the fuel injection pump by matching the control rack with the cut-off part of the gear case.

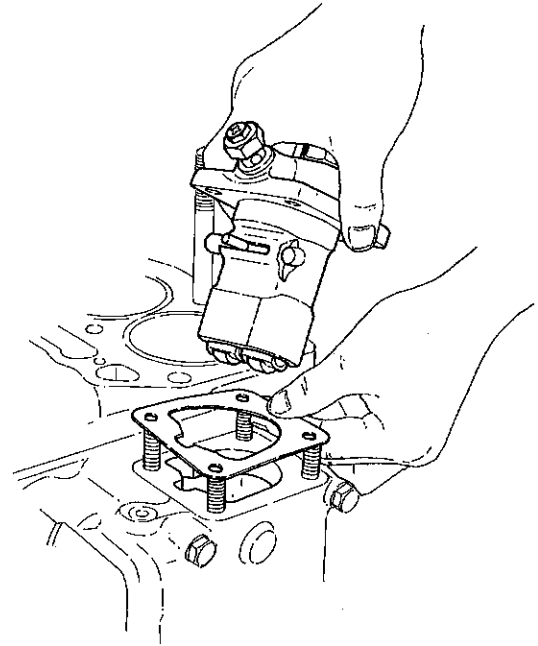

- (3) Remove the injection timing adjustment shims.
CAUTION: Note the number and total thickness of the timing adjustment shims.

4-3.18 Remove the timing gear case

- (1) Remove the gear case

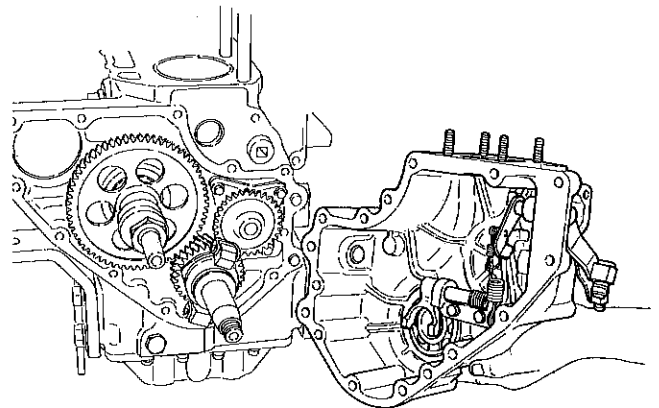

- (2) Remove the thrust collar, thrust needle bearing, and governor sleeve.

4-3.19 Remove the clutch assembly

Loosen the mounting flange bolts and remove the clutch assembly.

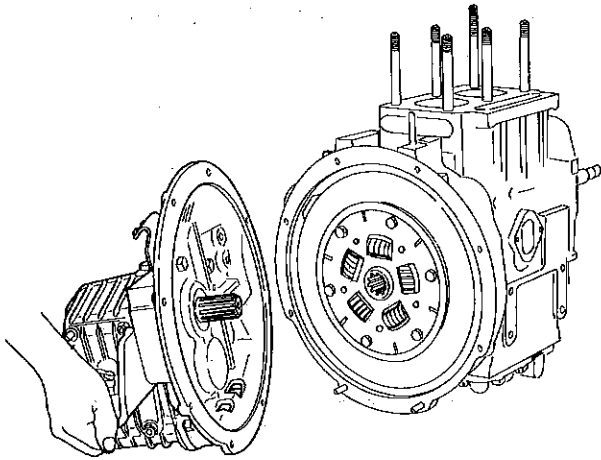

4-3.21 Remove the flywheel housing

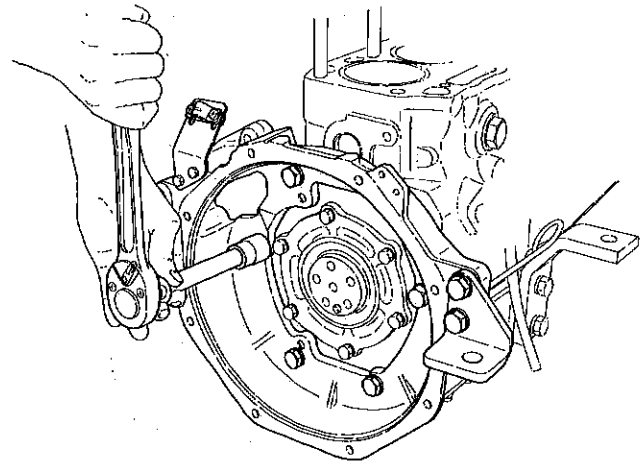

4-3.20 Remove the flywheel

(1) Remove the damper disk.

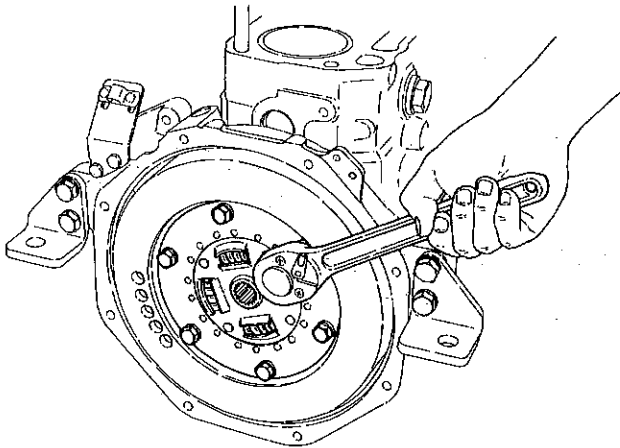

(2) Remove the flywheel.

Screw-in the two bolts to secure the clutch disk (slightly to the left and right of the flywheel) and remove it by pulling on the bolts.

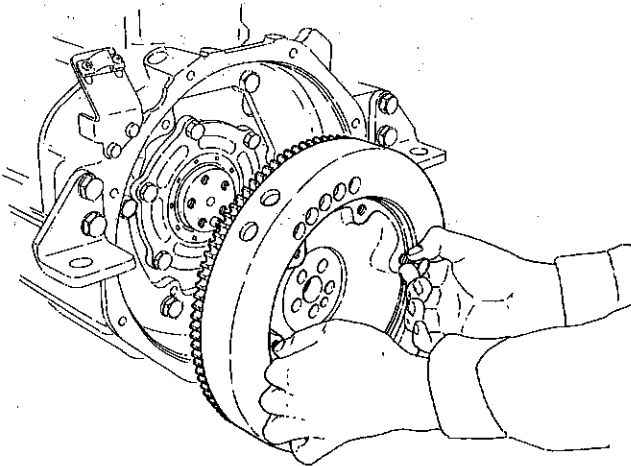

4-3.22 Remove the lubricating oil dipstick

4-3.23 Remove the feed pump

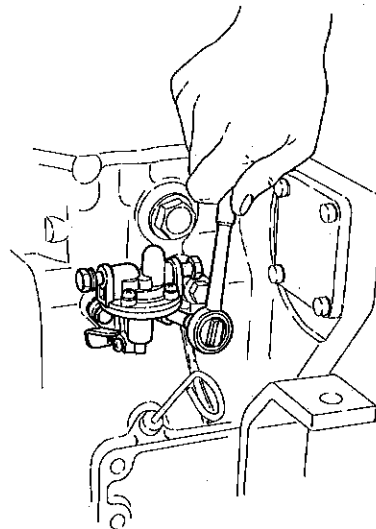

4-3.24 Remove the fuel cam

Remove the camshaft end nut and remove the fuel cam.

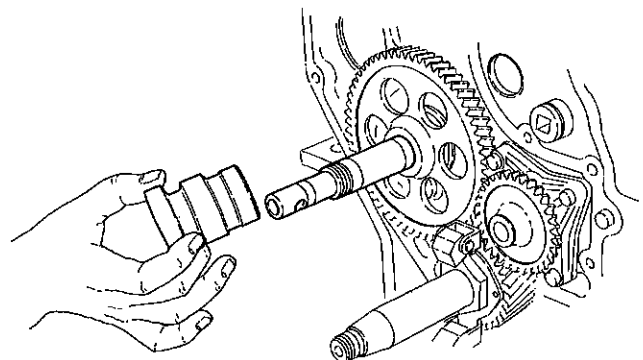

4-3.25 Remove the governor weight assembly

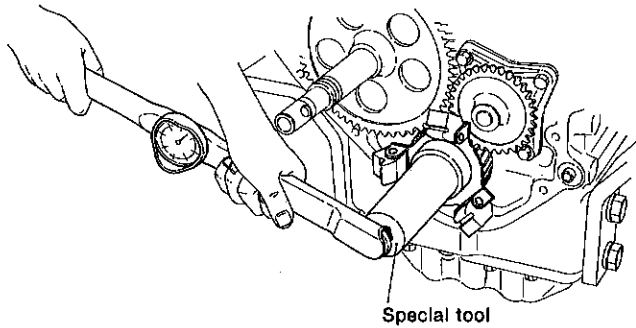

Special tool

Remove the crankshaft end nut and remove the governor weight assembly.

4-3.26 Remove the lubricating oil pump and driving gear assembly

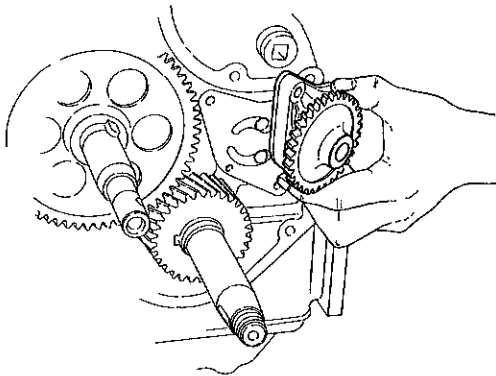

4-3.27 Remove the camshaft gear and the crankshaft gear

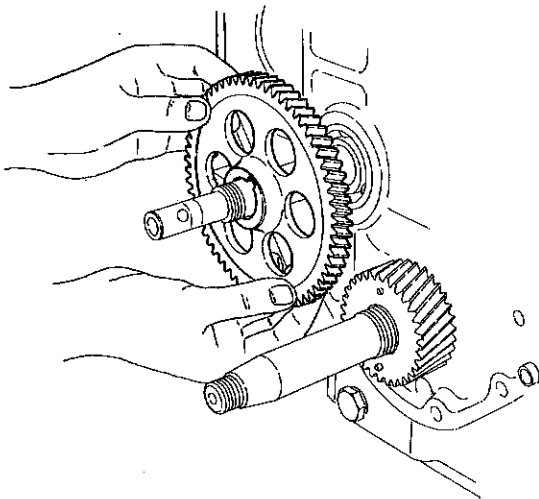

4-3.28 Turn the engine onto its side

- (1) Remove the engine feet of the crankshaft side
- (2) Turn the cylinder block over so that the crankshaft side is on the bottom.

4-3.29 Remove the oil pan and the oil intake pipe

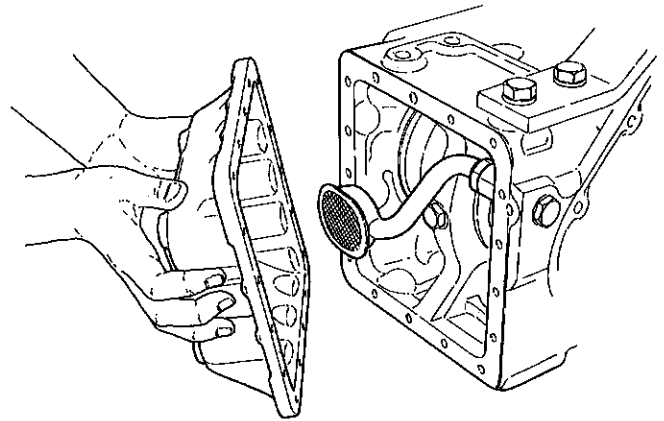

4-3.32 Remove the mounting bolt of the intermediate main bearing

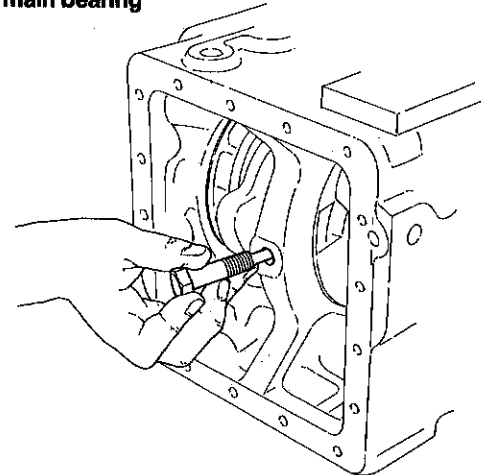

There are two intermediate main bearings, viz. No.1 and No.2, for engine model 3GM30F.

4-3.33 Pull the crankshaft

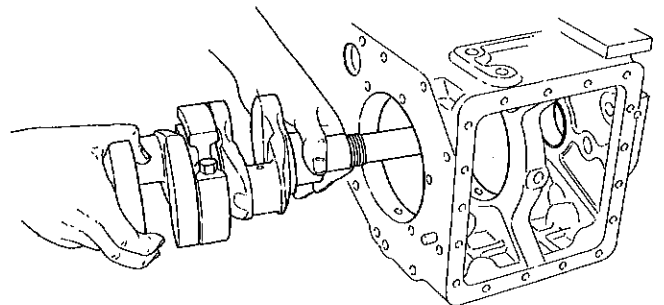

4-3.34 Remove the camshaft

(1) Remove the camshaft bearing set screw.

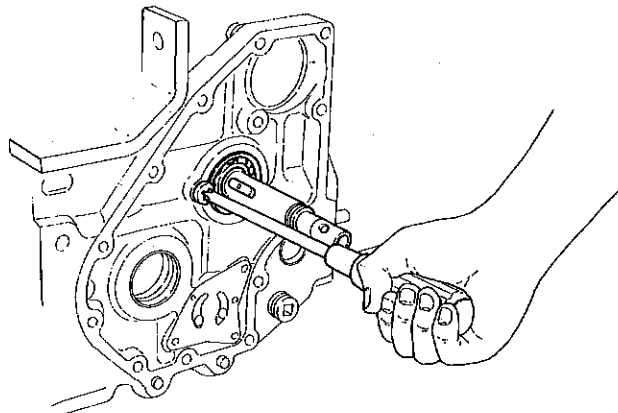

(2) Place the cylinder block upside down or raise the cylinder block by inserting a plate beneath it in order to prevent contact between the tappet and the cam.

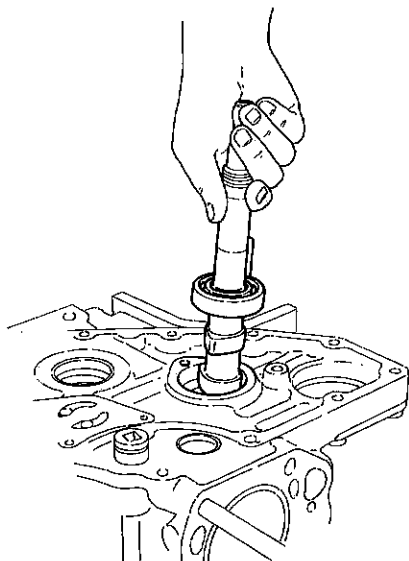

(3) Check that all the tappets are separated from the cam, and pull the camshaft out.

4-3.35 Remove the tappets

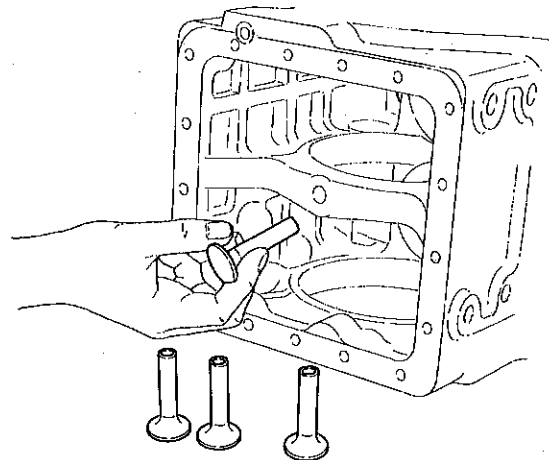

NOTE: Arrange the removed tappets by cylinder no. and intake and exhaust groups.

2. Reassembly of fresh water-cooled engine

In general, the reassembly of the fresh water-cooled engine is the same as that for a sea water-cooled engine, except for cooling system components such as the heat exchanger, fresh water pump, cooling water pipe and related parts.

For details of the reassembly sequence refer to chapter 14, Page 14-28~14-43 (Reassembly of Direct Sea-Water Cooling Engine)

For reference

5-3.1 Insert the tappets

- (1) Turn the cylinder block over or turn it upside down.
- (2) Coat the tappets with oil and insert into the tappet holes.

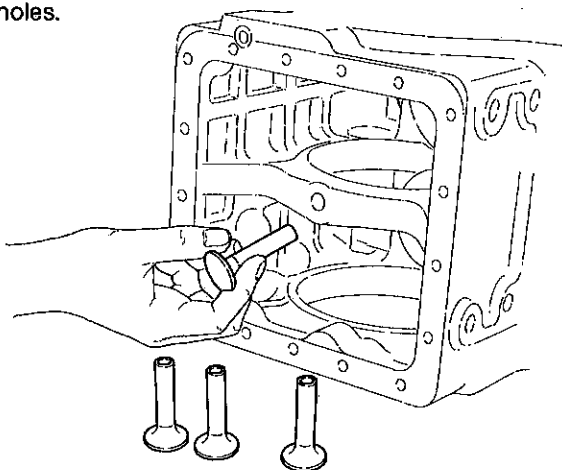

NOTE: Assemble the tappets in their original positions, paying careful attention to the cylinder numbers and intake and exhaust groupings.

5-3.2 Insert the camshaft

- (1) Coat the camshaft bearing section with oil and insert the camshaft into the cylinder block by tapping the shaft end with a plastic hammer.

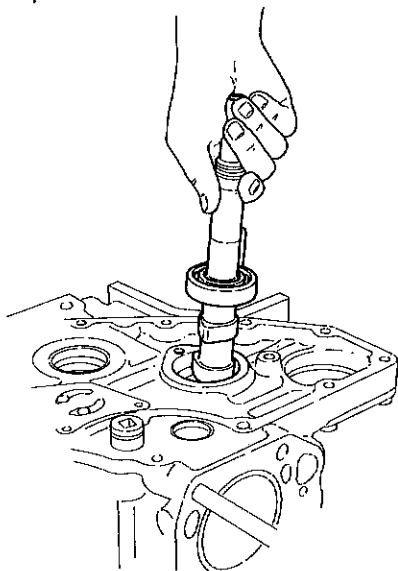

NOTE: Be careful not to damage the groove in the end of the shaft.

- (2) After inserting the camshaft, check that it rotates smoothly before tightening the camshaft bearing set screw.

Tightening torque	2 kg-m (14.5 ft-lb)
-------------------	---------------------

5-3.3 Install the crankshaft

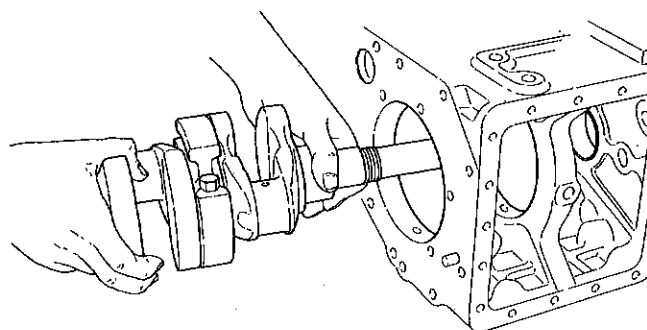

5-3.4 Tighten the set bolt of the intermediate main bearing

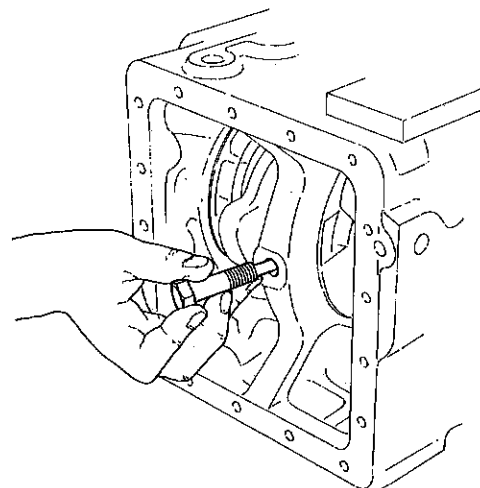

There are two intermediate main bearings, viz No.1 and No.2, for model 3GM30F

	kg-m (ft-lb)	
	2GM20F, 3GM30F	3HM35F
Tighten torque	4.5~5.0 (32.5~36.2)	7.0~7.5 (50.6~54.2)

5-3.5 Install the main bearing housing

- (1) Coat the oil seal section with oil.
- (2) Insert the main bearing housing and tighten.

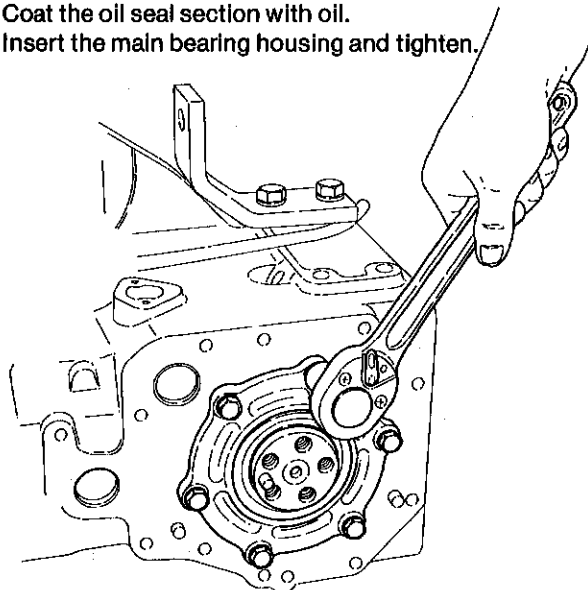

Tightening torque	2.5 kg-m (18 ft-lb)
-------------------	---------------------

- (3) Check that the crankshaft rotates smoothly.
- (4) Measure the crankshaft side gap, and adjust it to the prescribed value using the thickness of the packing.

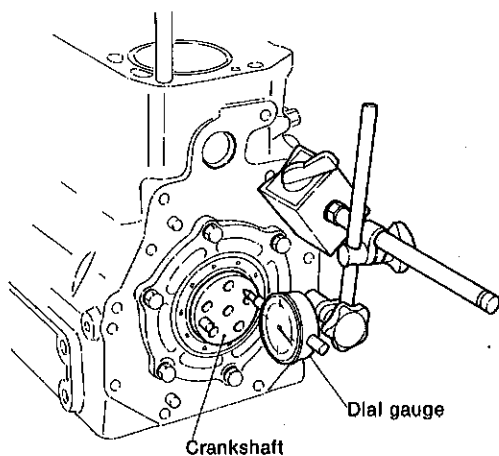

Crankshaft side gap	0.09 ~ 0.18mm (0.035 ~ 0.0071in.)
---------------------	--------------------------------------

5-3.6 Assemble the piston and connecting rod assembly

- (1) Coat the crankpin section with oil and position it so that the insertion side crank is at the top.
- (2) Coat the piston and crankpin bearing with oil.
- (3) Position the piston rings so that the gaps are 120° apart; make sure that there is no gap at the side pressure section.

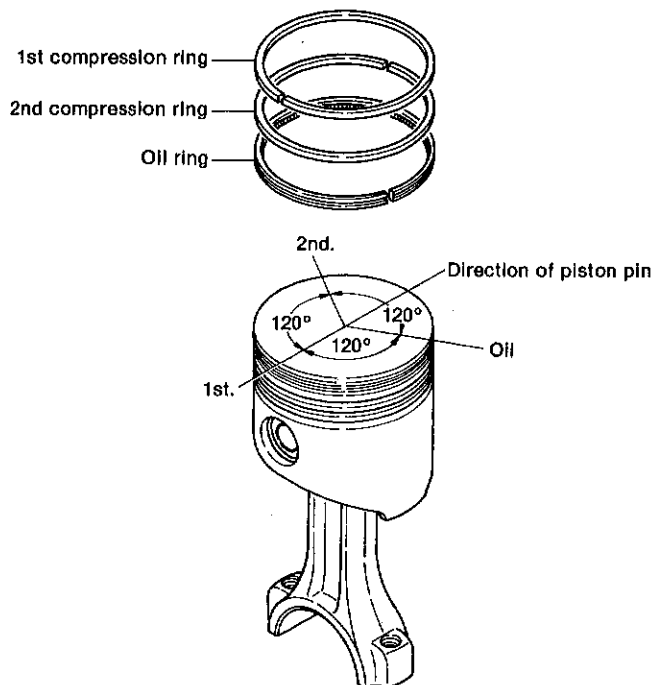

- (4) Insert the piston connecting rod assembly so that the side of the connecting rod large end with the identification number is on the exhaust side. Install the piston rings with a piston ring inserter.

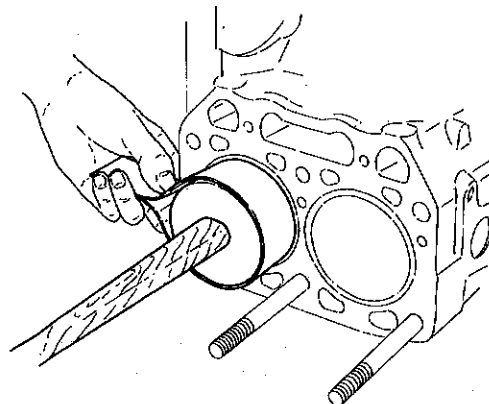

- (5) After the connecting rod large end makes contact with the crankpin, push the piston crown down slowly to turn the crankshaft to bottom dead center.
- (6) Align the connecting rod cap and connecting rod large end matching mark and tighten the connecting rod bolts.

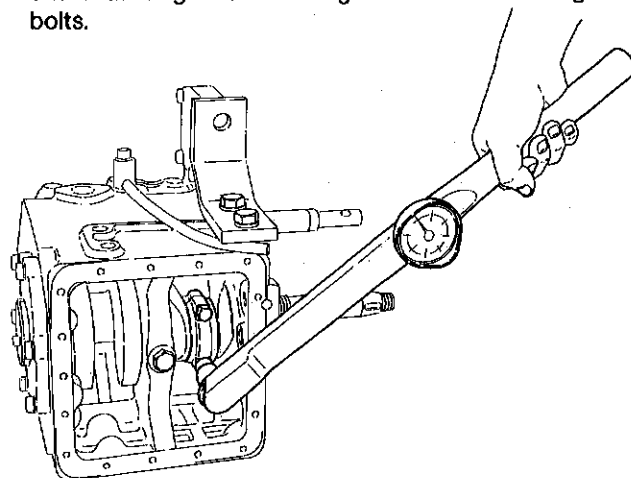

CAUTION: 1. Be careful to tighten the connecting rod bolts evenly.
 2. Coat the bolt threads and washer face with oil.

	kg·m (ft·lb)	
	2GM20F, 3GM30F	3HM35F
Tightening torque	2.5(18.1)	4.5(32.5)

(7) Measure the side clearance

Side clearance	0.2 ~ 0.4mm (0.0079 ~ 0.0157in.)
----------------	-------------------------------------

(8) Check that the crankshaft rotates smoothly.

5-3.7 Install the lubricating oil intake pipe

Coat the threads with "Screw Lock Super 203M", screw the pipe in and lock with the nut.

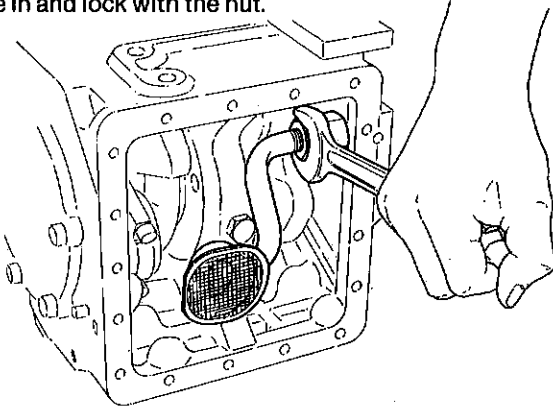

Screw-in distance	8 ~ 10mm (about 6 turns) (0.3149 ~ 0.3937in.)
-------------------	--

5-3.8 Install the engine bottom cover (oil pan)

- (1) Change the packing.
- (2) Install the bottom cover.

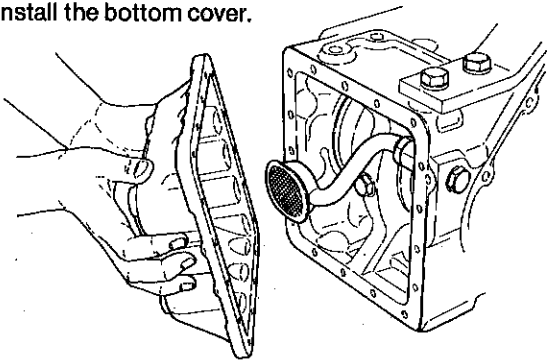

Tightening torque	0.9 kg·m (6.5 ft·lb)
-------------------	----------------------

5-3.9 Install the mounting flange

- (1) Set the engine upright.
- (2) Align the positioning pins and tighten the flange.

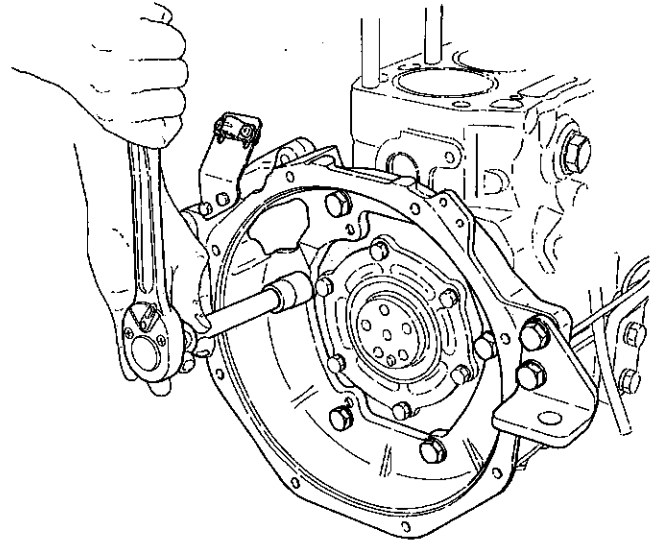

Tightening torque	4.5 kg·m (32.5 ft·lb)
-------------------	-----------------------

5-3.10 Install the flywheel

- (1) Align the reference pins.
- (2) Install the flywheel.

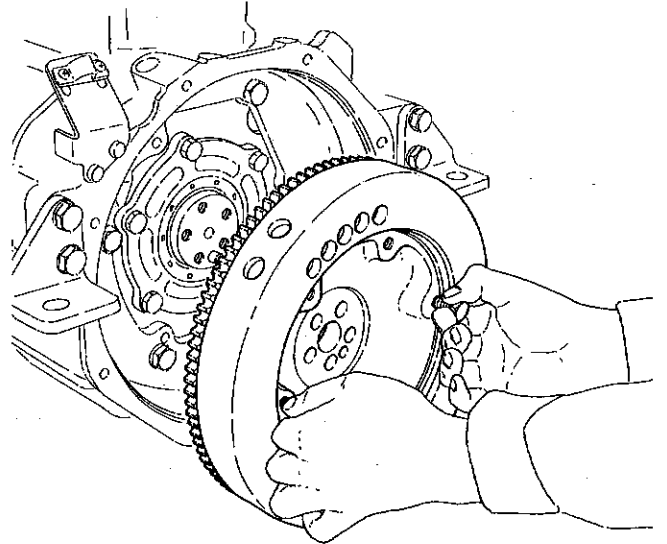

Tightening torque	6.5 ~ 7.0 kg·m (47 ~ 50.6 ft·lb)
-------------------	-------------------------------------

NOTE: After tightening, check the end run-out.

5-3.11 Install the clutch assembly

- (1) Install the clutch disc on the flywheel.

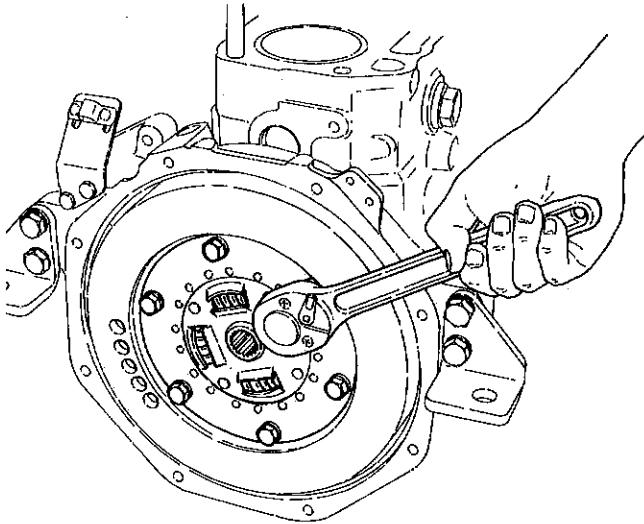

Tightening torque	2.5 kg-m (18 ft-lb)
-------------------	---------------------

- (2) Align the disc and input shaft spline, and install the clutch assembly on the mounting flange.

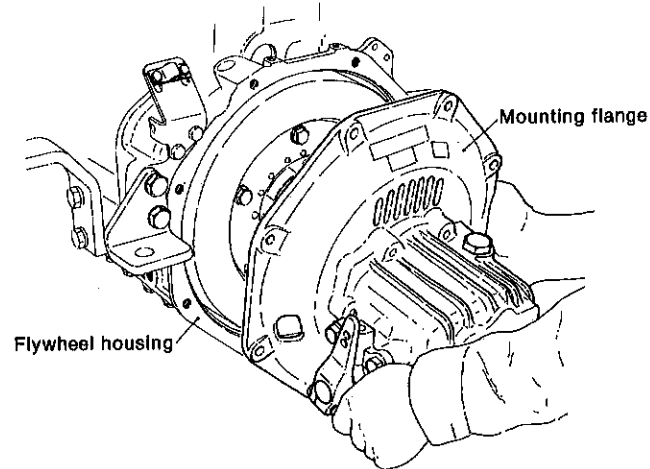

Tightening torque	2.0 ~ 2.5 kg-m (14.5 ~ 18.1 ft-lb)
-------------------	------------------------------------

5-3.12 Install the engine feet and set the engine in position

- (1) Dipstick flange and dipstick.
 (2) Fuel pump.

5-3.13 Install the lubricating oil pump

Install the lubricating oil pump and driving gear assembly.

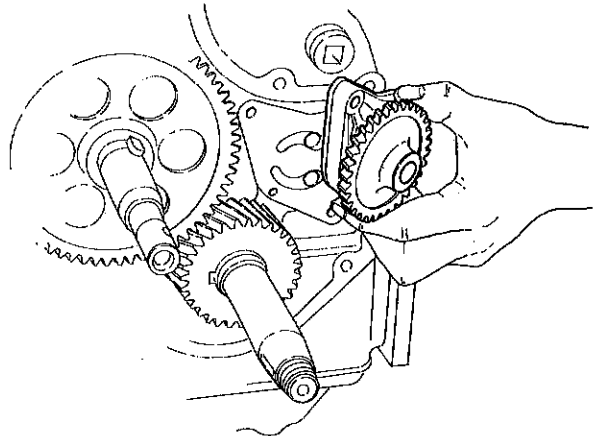

Lube pump body mounting bolt	0.9 kg-m (6.5 ft-lb)
------------------------------	----------------------

5-3.14 Assemble the camshaft gear and fuel cam

- (1) Coat the shaft hole of the camshaft gear with oil and insert the gear.
 (2) Coat the fuel cam with oil and insert the cam by aligning the "0" mark opposite the camshaft gear.

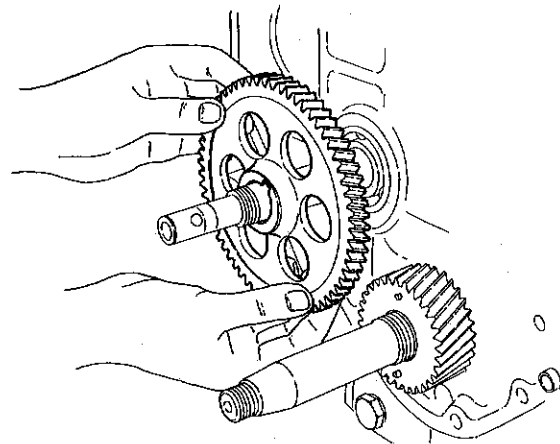

- (3) Tighten the camshaft end nut.

Tightening torque	7 ~ 8 kg-m (50.6 ~ 57.9 ft-lb)
-------------------	--------------------------------

5-3.15 Assemble the crankshaft gears

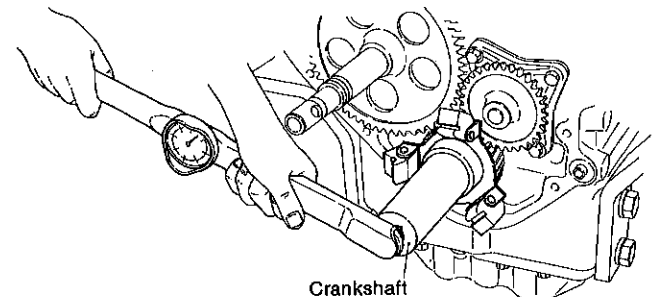

- (1) Coat the crankshaft section and the inside of the gear with oil.
 (2) Align the matching marks of the camshaft gear and the crankshaft gear and insert the crankshaft gear.

(3) After inserting the crankshaft gear, check the backlash.

Backlash	0.05 ~ 0.13mm (0.0020 ~ 0.0051in.)
----------	---------------------------------------

(4) Install the governor weight assembly and tighten the crankshaft end nut.

Tightening torque	8 ~ 10 kg-m (57.9 ~ 72.3 ft-lb)
-------------------	---------------------------------

5-3.16 Install the governor sleeve

Install the governor sleeve, thrust needle bearing and thrust collar.

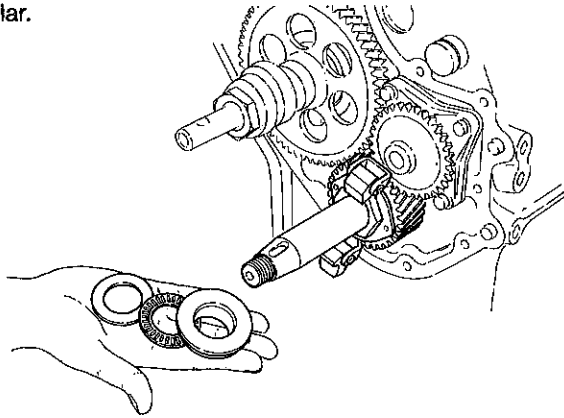

5-3.17 Install the timing gear case

- (1) Coat both sides of the new packing with "Three Bond 3B8-005" and install.
- (2) Install the timing gear case.

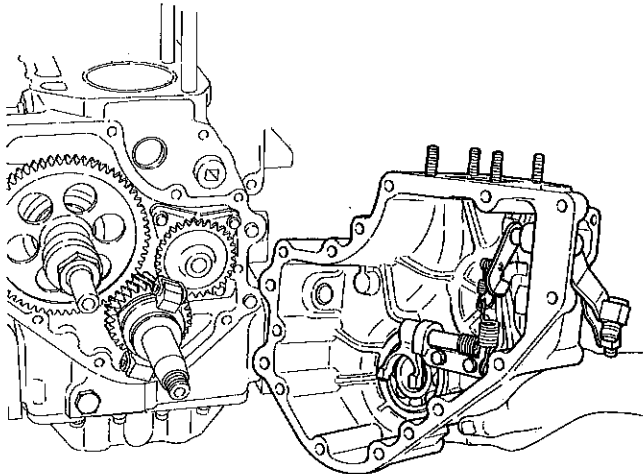

Tightening torque	2.5 kg-m (18 ft-lb)
-------------------	---------------------

5-3.18 Install the crankshaft V-pulley

- (1) Install the crankshaft key.
- (2) Coat the crankshaft V-pulley and the inside of the oil seal with oil.

(3) Insert and tighten the V-pulley, making sure that the lip of the oil seal is not distorted.

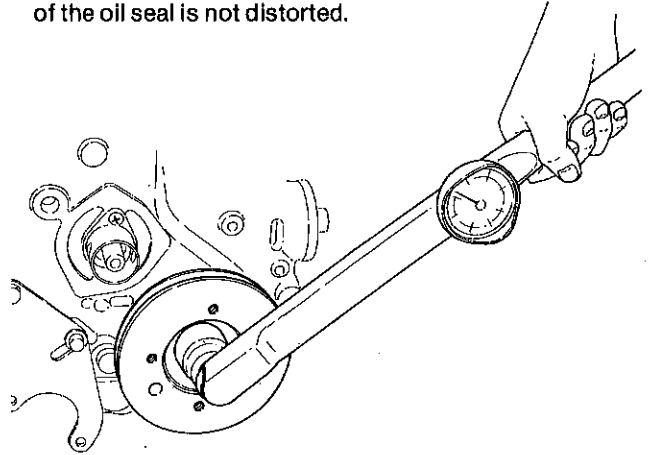

Tightening torque	10 kg-m (72.3 ft-lb)
-------------------	----------------------

5-3.19 Install the water pump

Install the V-belt to the crankshaft V-pulley and install the water pump.

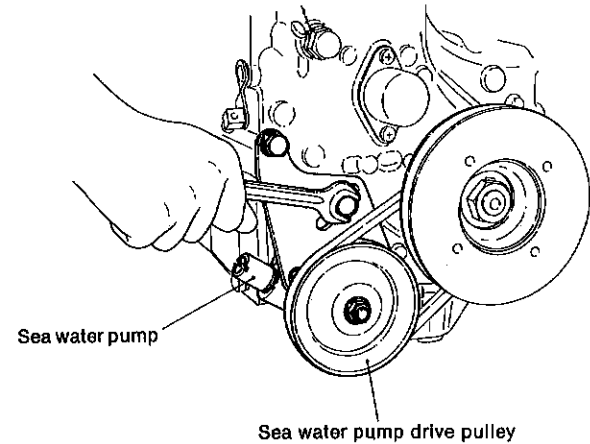

(1) V-belt tension .

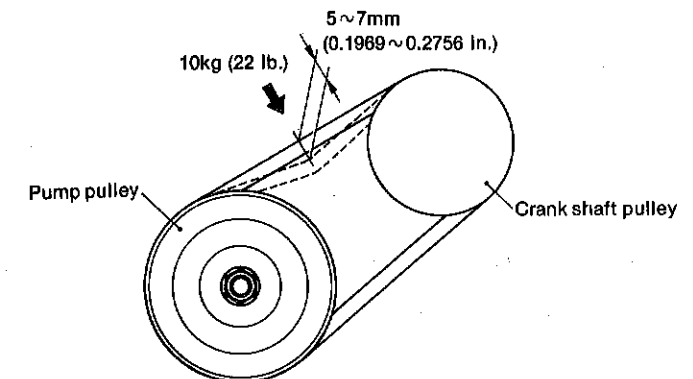

V-belt tension Pushed with a force of 10kg (22 lb.)	5 ~ 7mm (0.1969 ~ 0.2756 in.)
--	----------------------------------

(2) Tightening torque.

Tightening torque	2.5 kg-m (18 ft-lb)
-------------------	---------------------

(3) Insert the pump by looking through the gear case side cover, and align the governor No.2 lever and rack connecting part.

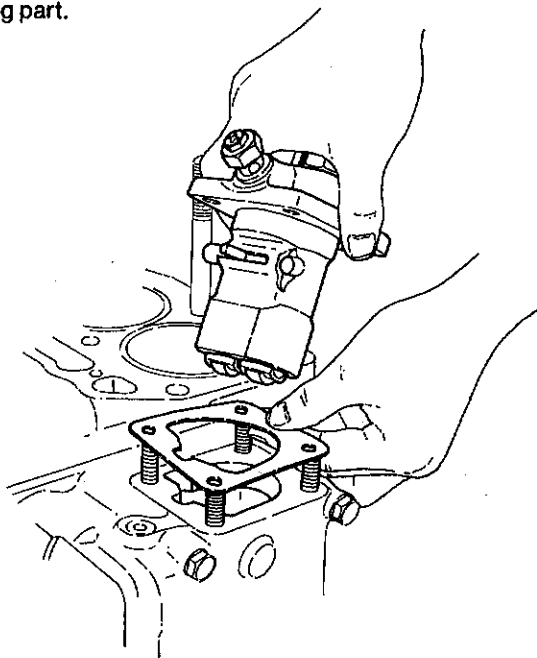

(2) Insert the cylinder head, being careful not to damage the threads of the tightening bolts, and tighten the nuts in the tightening sequence.

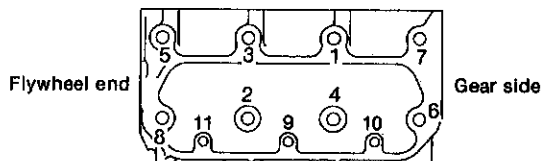
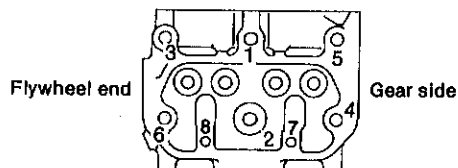
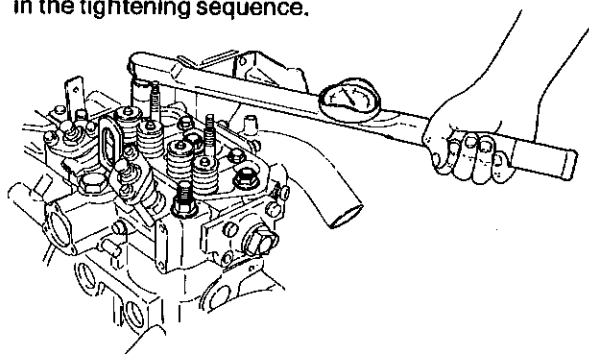

		kg-m (ft-lb)	
		2GM20F, 3GM30F	3HM35F
Tightening torque	Main (M12)	12.0(86.8)	13 (94.0)
	Sub (M8)	3.0(21.7)	3 (21.7)

(4) Tighten the fuel pump

Tightening torque	2.5 kg-m (18 ft-lb)
-------------------	---------------------

(5) Install the gear case side cover.

5-3.20 Install the cylinder head

(1) Install the gasket packing.

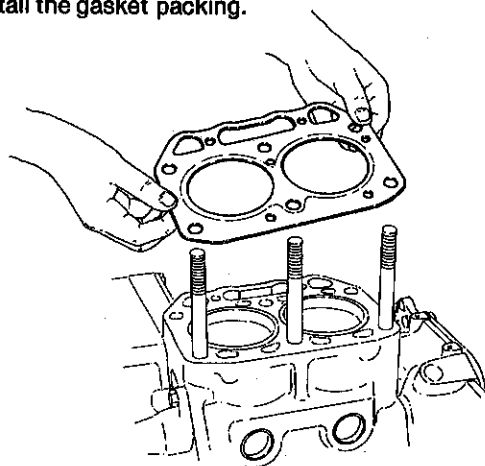

CAUTION: Take particular notice of the surfaces to be fitted.
 Keep the TOP mark on the cylinder head side.

(3) Install the water pipe

(from the thermostat cover to the cylinder inlet joint).

5-3.21 Install the rocker arms

(1) Install the push rods on the tappets.

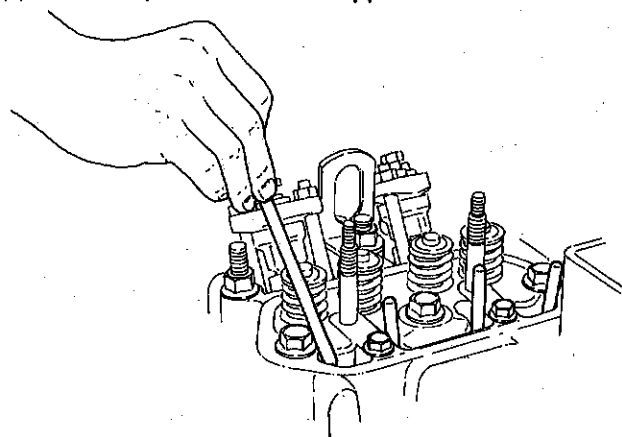

- (2) Coat the inside of valve spring retainer with oil.
- (3) Install the rocker arm shaft assembly and tighten the nut.

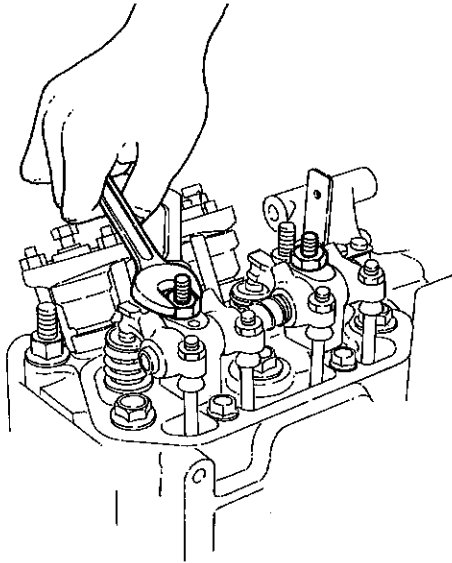

Tightening torque	3.7 kg-m (27 ft-lb)
-------------------	---------------------

CAUTION: 1. Loosen the valve head clearance adjusting screw in advance.

2. Check that the arm moves smoothly.

- (4) Adjust the intake and exhaust valve head clearance and lock with the nut.

Intake and exhaust valve head clearance (engine cold)	0.2mm (0.008in.)
---	------------------

5-3.22 Install the rocker arm cover

- (1) Install the rocker arm cover.

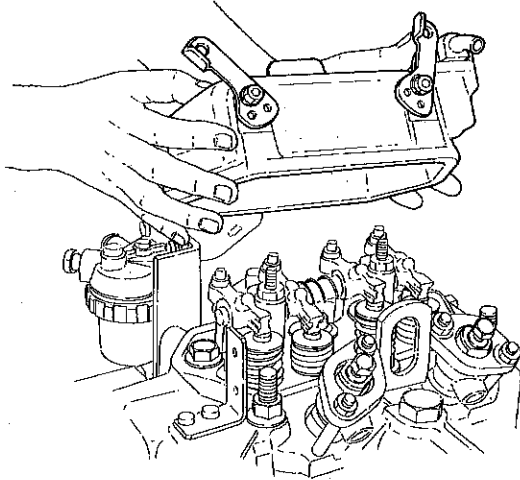

- (2) Install the breather pipe to the air intake pipe (intake manifold ... 3GM30F).

The following sequence is different from that of a sea water-cooled engine.

2-1. Install the starter motor

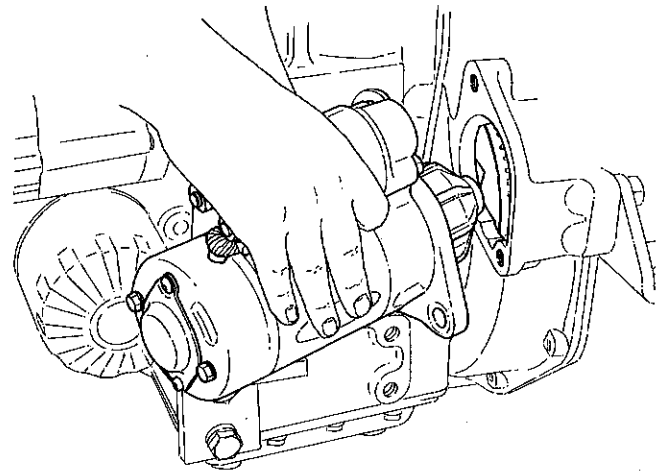

2-2. Install the oil filter

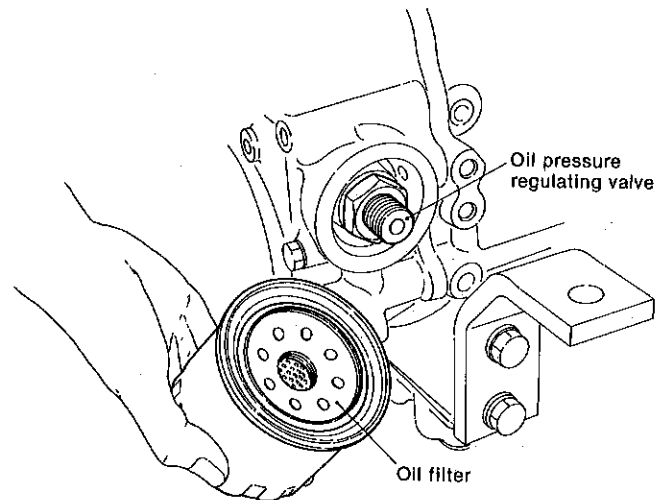

2-3. Assemble the high pressure fuel pipe and fuel return pipe

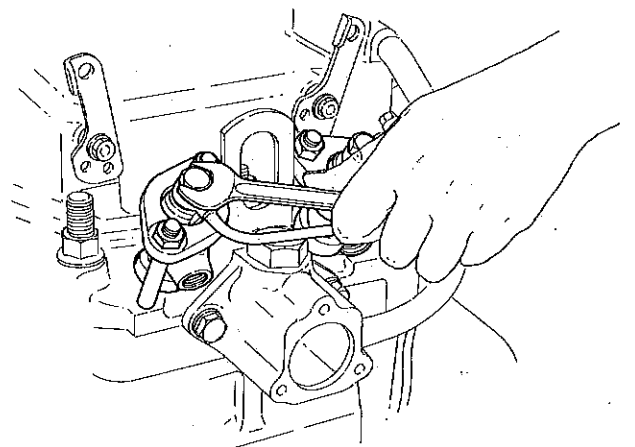

2-4. Install the intake silencer

- (1) Install the intake silencer cover to the air intake pipe.
 [intake manifold . . . 3GM30F and 3HM35F]
- (2) Install the intake silencer and tighten it with the clip.

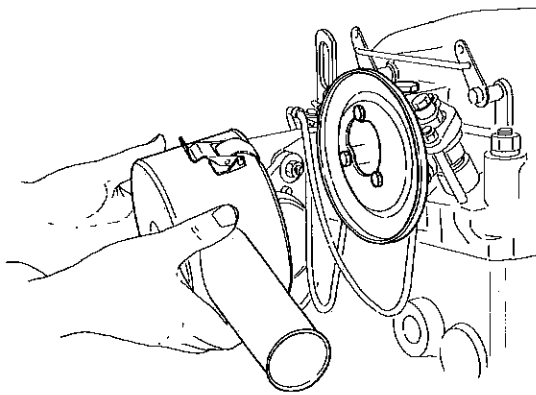

2-5. Assemble the CFW pump

Mount the CFW pump and replace the CFW hose between the CFW pump and cylinder block by connecting at the CFW pump and at the cylinder block.

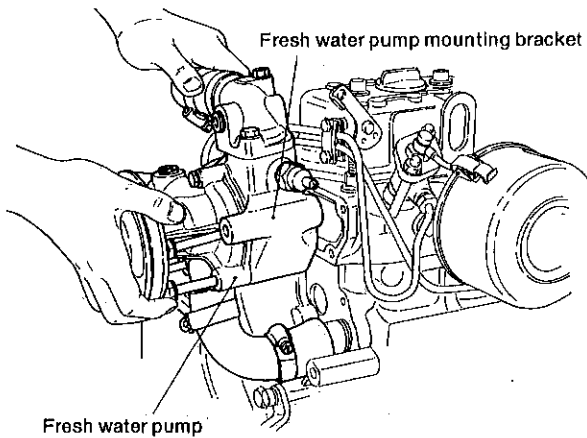

Fresh water pump

Tightening torque for CFW pump fixing bolt	2 ~ 2.5 kg-m (14.5 ~ 18 ft-lb)
--	--------------------------------

2-6. Install the alternator

- (1) Install the alternator to the bracket.

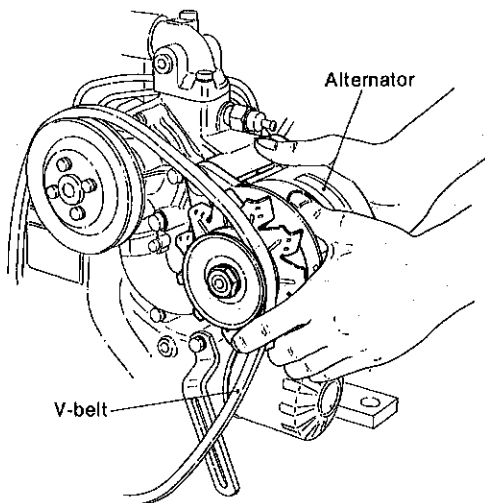

V-belt

- (2) Install the V-belt and tighten the adjusting bolt while adjusting the V-belt tension.

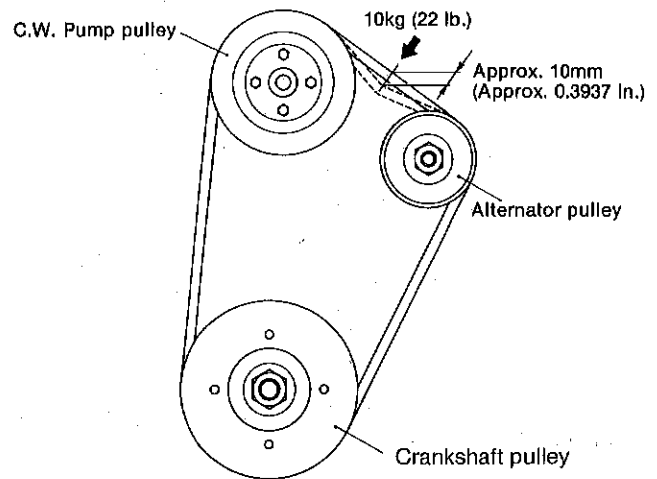
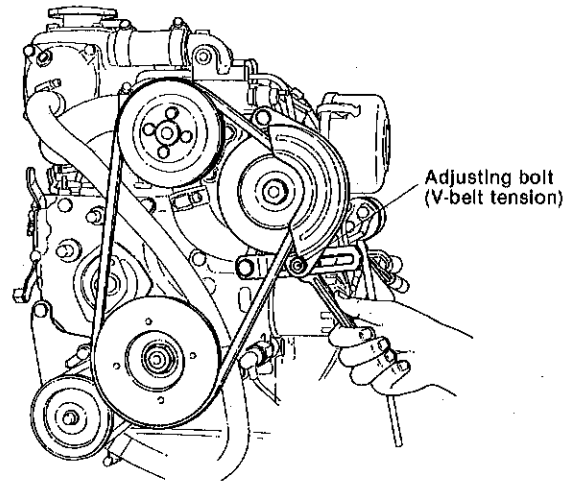
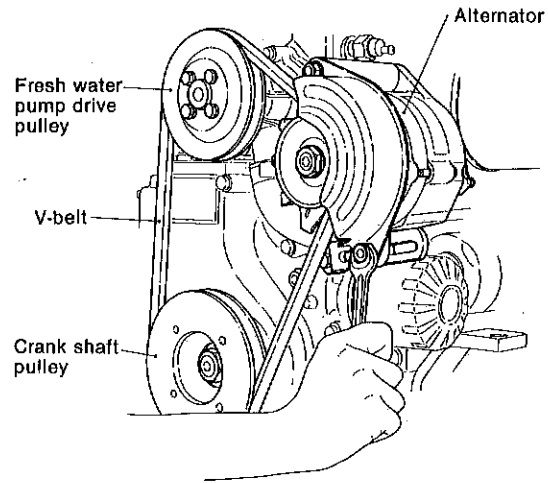

V-belt tension Pushed with a force of 10kg (22 lb.)	Approx. 10mm (Approx. 0.3937 in.)
--	--------------------------------------

2-7. Assemble the heat exchanger

Mount the heat exchanger and replace the CFW hose at the thermostat cover side by connecting the hose to the heat exchanger. Tighten the hose clamp after the heat exchanger is assembled.

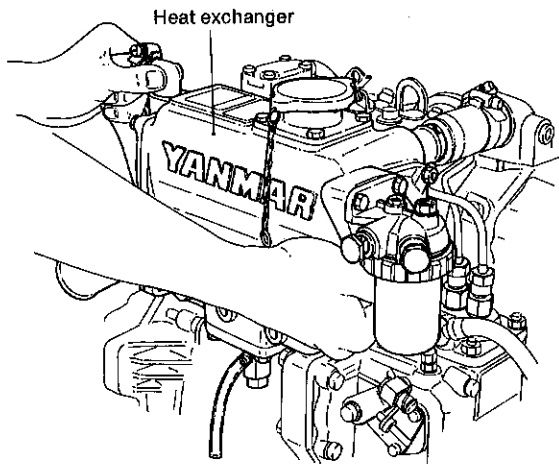

Tightening torque for heat exchanger fixing bolt	2 ~ 2.5 kg-m (14.5 ~ 18 ft-lb)
--	-----------------------------------

2-8. Assemble the fuel feed pump (3GM30F)

For model 3GM30F engine assemble the fuel feed pump after the heat exchanger is assembled.

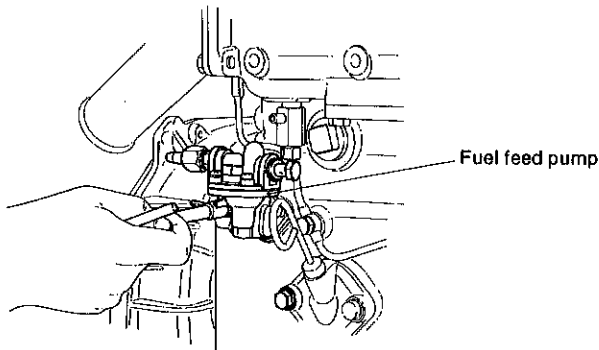

2-9. Assemble the fuel oil pipe

- (1) Fuel feed pump — fuel filter
- (2) Fuel filter — fuel injection pump

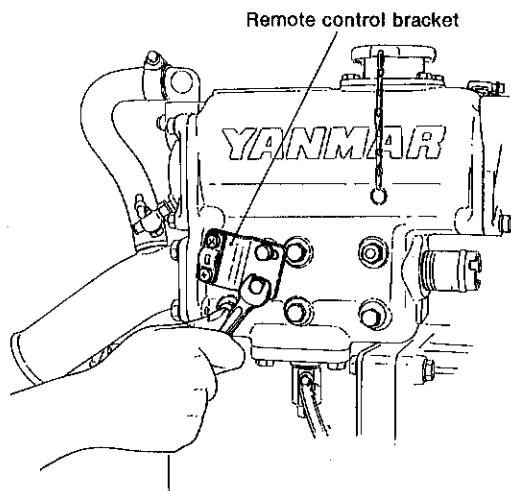

2-10. Assemble the cooling water pipe

- (1) CFW hose (heat exchanger — CFW pump)

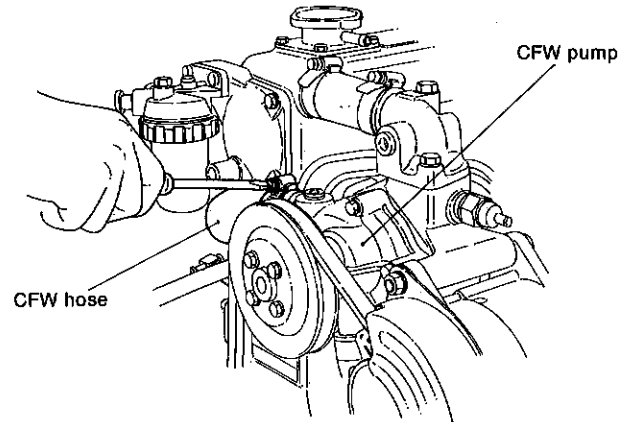

- (2) CSW hose (CSW pump — heat exchanger)

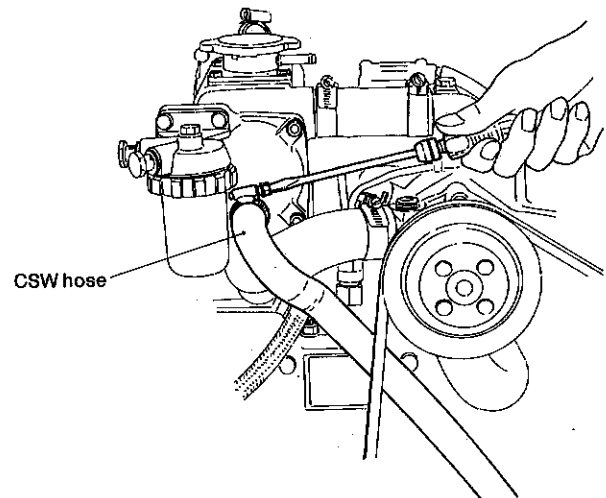

2-11. Connect the electrical wiring

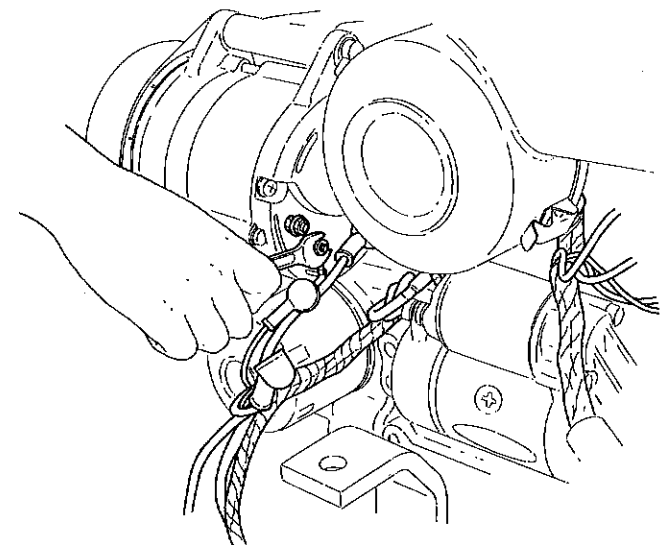

2-12. Install the remote control cables

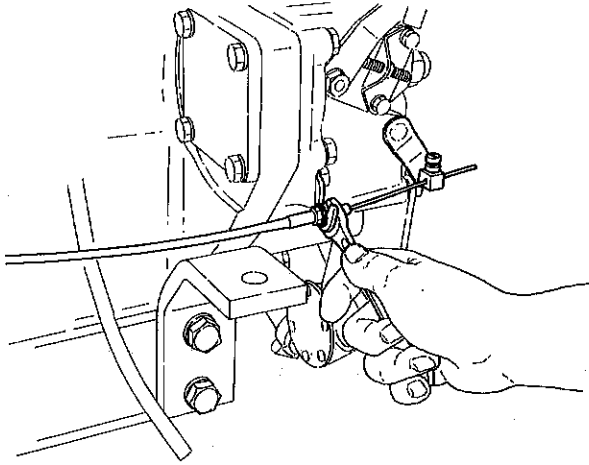
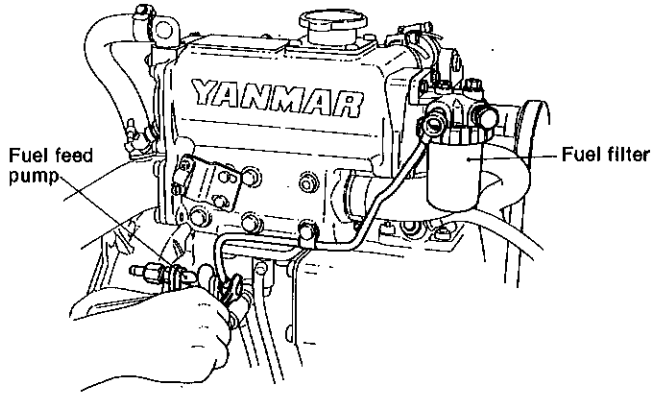

2-13. Connect the interior piping

3. Tightening Torque

The bolts and nuts used in this engine employ ISO general metric threads stipulated in JIS (Japanese Industrial Standards). Pay careful attention to the thread dimensions when replacing bolts and nuts.

Tighten the bolts and nuts to the tightening torque given in the table below.

3-1 Main bolt and nut tightening torque

Location	Bolt/nut		1GM10(C)	2GM20(F)(C)	3GM30(F)(C)	3HM35(F)(C)	Remarks	
Cylinder head	Cylinder head tightening bolt and nut	Thread diameter	M10	M12			nut and bolt	
			—	M8			Aux. bolt	
		Quantity	4	6	8	8	Nut and bolt	
			—	2	3		Aux. bolt	
		Tightening torque kg-m(ft-lb)	7.5(54.248)	12.0(86.8)		13(94.029)	Nut and bolt	
			—	3.0(21.7)		3(21.699)	Aux. bolt	
	Rocker arm support nut	Thread diameter	M8	M10				
		Quantity	1	2	3	3		
		Tightening torque kg-m(ft-lb)	3.7 (26.762)					
	Exhaust manifold nuts	Thread diameter x pitch mm	M8 x 1.25					
		Quantity	2	3	6			
		Tightening torque kg-m(ft-lb)	4.5(32.549)					
Anticorrosion zinc	Thread diameter	—	M25					
	Quantity	—	1					
	Tightening torque kg-m(ft-lb)	—	5~6 (36.165~43.398)					
Timing gear	Timing gear case mounting bolt	Thread diameter x pitch mm	M6 x 1.0	M8 x 1.25				
		Quantity	12					
		Tightening torque kg-m(ft-lb)	0.9(6.510)	2.5(18.083)				
	Camshaft end nut	Thread diameter x pitch mm	M20 x 1.5		M18 x 1.5			
		Quantity	1					
		Tightening torque kg-m(ft-lb)	7~8(50.631~57.864)					
	Governor weight set nut	Thread diameter x pitch mm	M26 x 1.5					
		Quantity	1					
		Tightening torque kg-m(ft-lb)	8~10(57.864~72.330)					

Chapter 15 Disassembly and Reassembly
3. Tightening Torque

SM/GM(F)(C)-HM(F)(C)

Location	Bolt/nut		1GM10(C)	2GM20(F)(C)	3GM30(F)(C)	3HM35(F)(C)	Remarks	
Cylinder block	Mounting flange bolt	Thread diameter x pitch mm	M10 x 1.5					
		Quantity	6					
		Tightening torque kg-m(ft-lb)	4.5(32.549)					
	Bottom cover bolt	Thread diameter x pitch mm	M6 x 1.0					
		Quantity	13	17	21	23		
		Tightening torque kg-m(ft-lb)	0.9(6.510)					
	Oil pressure switch mounting	Thread diameter	PT 1/8					
		Quantity	1					
		Tightening torque kg-m(ft-lb)	1.0(7.233)					
Crankshaft, pistons	Main bearing housing bolt	Thread diameter x pitch mm	M8 x 1.25					
		Quantity	6					
		Tightening torque kg-m(ft-lb)	2.5(18.083)					
	Connecting rod bolt	Thread diameter x pitch mm	M7 x 1.0			M9 x 1.0		
		Quantity	1 x 2 = 2	2 x 2 = 4	3 x 2 = 6			
		Tightening torque kg-m(ft-lb)	2.5(18.083)			4.5(0.6221)		
	Crankshaft V-pulley bolt	Thread diameter	M18					3HM35(F)(C) Counterclock- wise screw
		Quantity	1					
		Tightening torque kg-m(ft-lb)	10(72.330)					
	Flywheel bolt	Thread diameter x pitch mm	M10 x 1.25					
		Quantity	5					
		Tightening torque kg-m(ft-lb)	6.5~7.0(47.015~50.631)					
	Diameter disk bolt	Damper diameter x pitch mm	M8 x 1.25					
		Quantity	6			8		
		Tightening torque kg-m(ft-lb)	2.5(18.083)					
	Intermediate main bearing housing bolt	Thread diameter x pitch mm	—	M8 x 1.25				
		Quantity	—	2 x 2 = 4	3 x 2 = 6			
		Tightening torque kg-m(ft-lb)	—	3.0~3.5 (21.699~25.316)		4.5~5.0 (32.549~36.165)		
Intermediate main bearing housing set bolt	Thread diameter x pitch mm	—	M10 x 1.25					
	Quantity	—	1	2				
	Tightening torque kg-m(ft-lb)	—	4.5~5.0 (32.549~36.165)		7.0~7.5 (50.631~54.246)			
Cooling system	Water temperature sender bolt	Thread diameter	PT 3/8					
		Quantity	1					
		Tightening torque kg-m(ft-lb)	1.0~1.5(7.2330~10.850)					

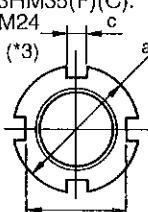
Location	Bolt/nut		1GM10(C)	2GM20(F)(C)	3GM30(F)(C)	3HM35(F)(C)	Remarks	
Cooling system	Anticorrosion zinc mounting (Cylinder block)	Thread diameter x pitch mm						1GM10(C): Flange type 2GM20(C), 3GM30(C) and 3HM35(C): Plug type
		Quantity	1		2			
		Tightening torque kg-m(ft-lb)	5~6(36.165~43.498)					
	Cooling water inlet joint	Thread diameter x pitch mm						
		Quantity	1					
		Tightening torque kg-m(ft-lb)						
	Water pump body bolt	Thread diameter x pitch mm	M6 x 1.0	M8 x 1.25				
		Quantity	3	2				
		Tightening torque kg-m(ft-lb)	0.9(6.5097)	2.5(18.083)				
Fuel system	Nozzle nut	Thread diameter x pitch mm	M20 x 1.5					
		Quantity	1	2	3			
		Tightening torque kg-m(ft-lb)	10(72.330)					
	Delivery valve holder	Thread diameter	M18					
		Quantity	1	2	3			
		Tightening torque kg-m(ft-lb)	4.0~4.5(28.932~32.549)					
	Fuel injection nozzle flange nut	Thread diameter x pitch mm	M8 x 1.25					
		Quantity	2 x 1 = 2	2 x 2 = 4	2 x 3 = 6			
		Tightening torque kg-m(ft-lb)	2(14.466)					
Clutch system	Clutch housing nut	Thread diameter x pitch mm	M8 x 1.25					(*2) GM-series: M18 x 1.5 3HM35(F)(C): M24  (*3) a: 39.5 (1.5551) b: 32 (1.2598) c: 7 (0.2755)
		Quantity	8					
		Tightening torque kg-m(ft-lb)	2.0~2.5(14.466~18.083)					
	Clutch mounting bolt	Thread diameter x pitch mm	M8 x 1.25					
		Quantity	8					
		Tightening torque kg-m(ft-lb)	2.0~2.5(14.466~18.083)					
	Output shaft coupling tightening nut	Thread diameter x pitch mm	(*2)					
		Width B/C mm (in.)	30/34.6(1.1811/1.3622)		(*3)			
		Quantity						
		Tightening torque kg-m(ft-lb)	10±1.5 (72.330~10.850)		9.5 (68.714)			
	Starter motor mounting top	Thread diameter x pitch mm	M10 x 1.5		M12			
		Quantity	2					
Tightening torque kg-m(ft-lb)		4.5~5.0 (32.549~36.165)		7.5~8.0 (54.248~57.864)				
Electric system	AC generator mounting bolt	Thread diameter x pitch mm	M8 x 1.25					
		Quantity	3					
		Tightening torque kg-m(ft-lb)	2.2~2.7(15.913~19.530)					

3-2 General bolt and nut tightening torque

kg-m (ft-lb)

Diameter of thread	General bolts 7T	Pipe joint bolts
M6	0.9±0.1 (5.9 ~ 7.2)	—
M8	2.5±0.2 (16.6 ~ 19.5)	1.2 ~ 1.7 (8.7 ~ 12.3)
M10	4.7±0.3 (31.8 ~ 36.2)	—
M12	8.0±0.5 (54.2 ~ 61.5)	2.5 ~ 3.5 (18.1 ~ 25.3)
M14	13.0±0.5 (90.4 ~ 97.6)	4.0 ~ 5.0 (28.9 ~ 36.2)
M16	20.5±0.5 (144.7 ~ 151.9)	5.0 ~ 6.0 (36.2 ~ 43.4)

4. Packing Supplement and Adhesive Application Points

The packing used in this engine is asbestos sheet sealed at both mating faces.

Be sure to use the correct supplement in accordance with the table below.

Location	Packing (coated)	Packing agent and adhesive
Cylinder head	Both sides of cylinder head side cover packing Cylinder head top and bottom casting sand hole plug Rocker arm chamber packing (rocker arm chamber side) Both sides of cylinder head gasket packing Intake and exhaust manifold bolt threads Exhaust manifold stud bolt thread Rocker arm support stud bolt Cooling water outlet joint threads	"Three Bond No. 4" "Three Bond No. 50" "Screw Lock Super 203M" "Screw Lock Super 203M"
Timing gear	Both sides of timing gear case packing Both sides of fuel injection timing adjustment shims Both sides of governor chamber packing Governor drive shaft bearing cover packing	"Three Bond 3B8-005" "Screw Lock Super 203M" "Three Bond 3B8-005"
Cylinder block	Both sides of oil pan packing Outside surface of cylinder liner Cooling water pipe joint threads Lubricating oil suction pipe threads Lubricating oil intake pipe blind plug threads Oil pressure regulator valve threads Oil pressure switch threads Cylinder head bolt stud Mounting flange face Lube oil pump face Both sides of bushing shell packing Both sides of dipstick flange packing Both sides of fuel pump packing	"Three Bond 3B8-005" White paint "Three Bond No. 20" "Screw Lock Super 203M" "Three Bond 3B8-005"
Crankshaft, piston	Crankshaft V-pulley key groove tightening section Connecting rod bolt threads	"Three Band 3B8-005"
Cooling system	Both sides of water pump packing Both sides of water pump packing Anticorrosion zinc flange threads Water temperature switch threads Water drain joint (cylinder, exhaust pipe)	"Three Bond No. 2" "Three Bond No. 4"
Clutch system	Mounting flange face Clutch housing face	





YANMAR DIESEL ENGINE CO.,LTD.

1-32, CHAYAMACHI, KITA-KU, OSAKA 530 JAPAN TEL.(06)376-6211 TELEX63436 YANMARJ FAX.(06)372-2455

Printed in Japan
0000A0A1361